

TracVision® LF/SF Installation Guide

These instructions explain how to install the TracVision LF/SF satellite TV antenna system on a vehicle. Complete instructions on how to use the system are provided in the *User's Guide* and the selected receiver's owner's manual.

Step	See Page:
1. Inspect Parts and Get Tools	2
2. Plan the Installation	3
3. Remove the Shipping Restraint	4
4. Mount the Antenna	5
5. Cut the Switchplate Mounting Hole	6
6. Wire the Antenna	7
7. Seal the Cable Access Hole	8
8. Wire the Receiver(s)	9
9. Wire the Switchplate	10
10. Mount the Switchplate	11
11. Test the System	12

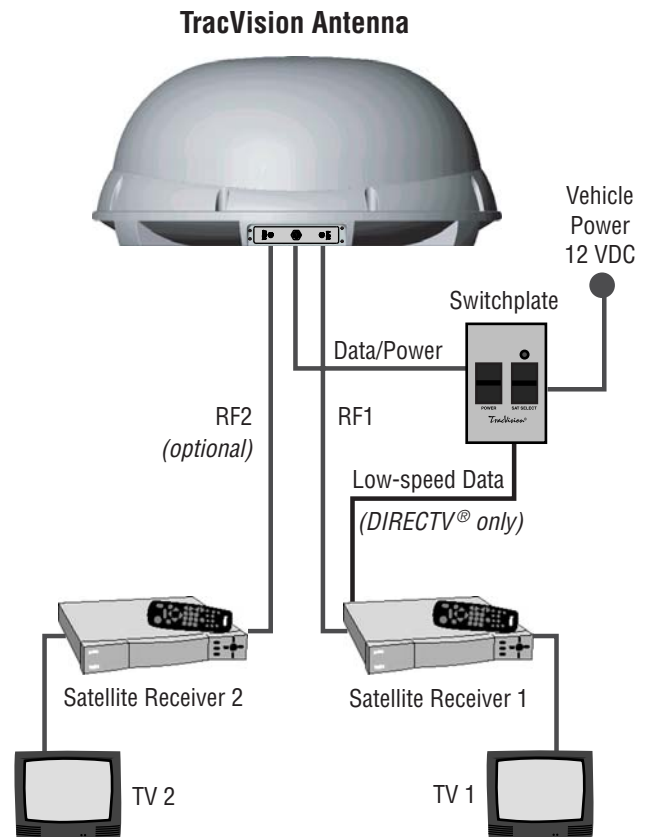

Technical Support

If you need technical assistance, please contact KVH Technical Support:

Phone: 1-401-847-3327

E-mail: techs@kvh.com

Internet: www.kvh.com/help

1 Inspect Parts and Get Tools



Always lift the antenna unit by the gray baseplate, never by the radome!



1. Unpack the box and ensure it contains everything shown on the *Contents List*. *Note: Cables for the LF/SF system are stored beneath the antenna unit during shipping.*
2. Carefully examine all of the supplied parts to ensure nothing was damaged in shipment.
3. Gather all of the tools and materials listed below. You will need these items to complete the installation.
 - Electric drill
 - $\frac{3}{16}$ " drill bit
 - $\frac{3}{4}$ " hole saw and auger bit
 - #2 Phillips and #0 flat tip screwdrivers
 - Silicone sealant or RTV
 - $\frac{7}{16}$ "-open end wrench
 - Adhesive suitable for specific roof construction and materials (e.g., Liquid Nails)
 - Rivet gun and $\frac{3}{16}$ "-rivets (or other fastener suitable for specific roof construction)
 - RG6 or RG11 (75 ohms) RF cable (if installing more than one receiver)
 - Augat IT1000 Tool (KVH part #19-0242)
 - Snap-N-Seal® F-connector(s) (KVH part #23-0170)

2 Plan the Installation

Before you begin, consider the following installation guidelines:

- The antenna requires a 15° to 75° look angle and must have an unobstructed view of the southern sky to receive satellite TV.
- Find a location on a flat part of the roof on the centerline of the vehicle, away from any obstructions that might block the satellite signal (the antenna should be at least 18" away from the nearest air conditioner).



If you need to paint the radome, **use ONLY non-metallic automotive paint without a primer coat.** Metallic paint or paint having metallic color will block satellite signals.

Figure 1 Antenna Blockage

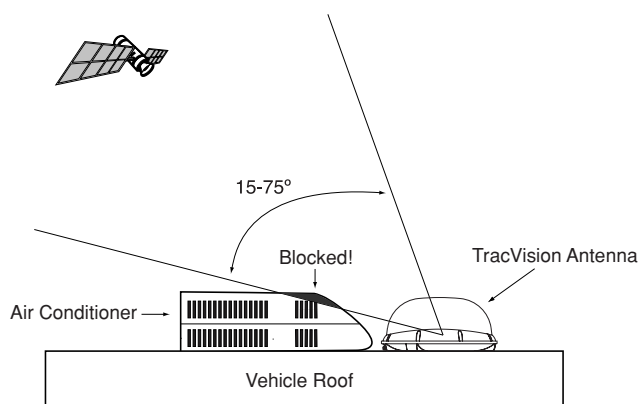

- The antenna must be mounted on a horizontal surface with a minimum roof (or other mounting surface) radius of 250". When placed flat on the mounting surface, the mounting plates should be less than $\frac{7}{16}$ " above the mounting surface (see Figure 2).



Any gap larger than $\frac{7}{16}$ " will warp the baseplate and seriously damage the antenna.

Figure 2 Maximum Mounting Surface Slope

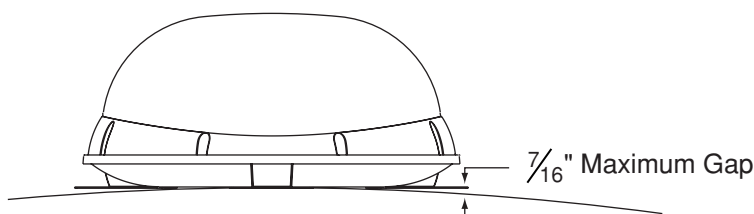

- When choosing a location for the switchplate, find a dry, flat location that will be easily accessible to the user. Take into account cable lengths between components, as well as accessibility to the equipment after installation.

3 Remove the Shipping Restraint



Once you remove the shipping restraint, handle the antenna unit carefully. Improper handling may damage the unit.

1. At the bottom of the antenna baseplate, cut the tie-wrap and pull it out of the baseplate. *You do not need to remove the radome.* This tie-wrap secures the antenna's LNB (low-noise block) to prevent shipping damage (see Figure 3).

Figure 3 Shipping Restraint

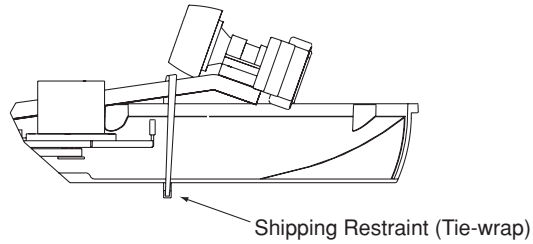

2. After removing the tie-wrap, seal the two holes with the plugs provided in the kitpack (see Figure 4).

Figure 4 Antenna Baseplate (Bottom View)

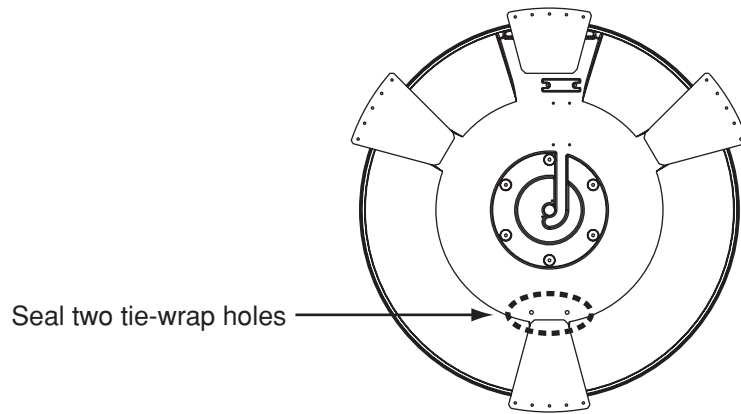

4 Mount the Antenna

1. Apply construction adhesive to the bottom of the antenna's four mounting plates across all of the holes.

Figure 5 Proper Orientation of the Antenna Unit

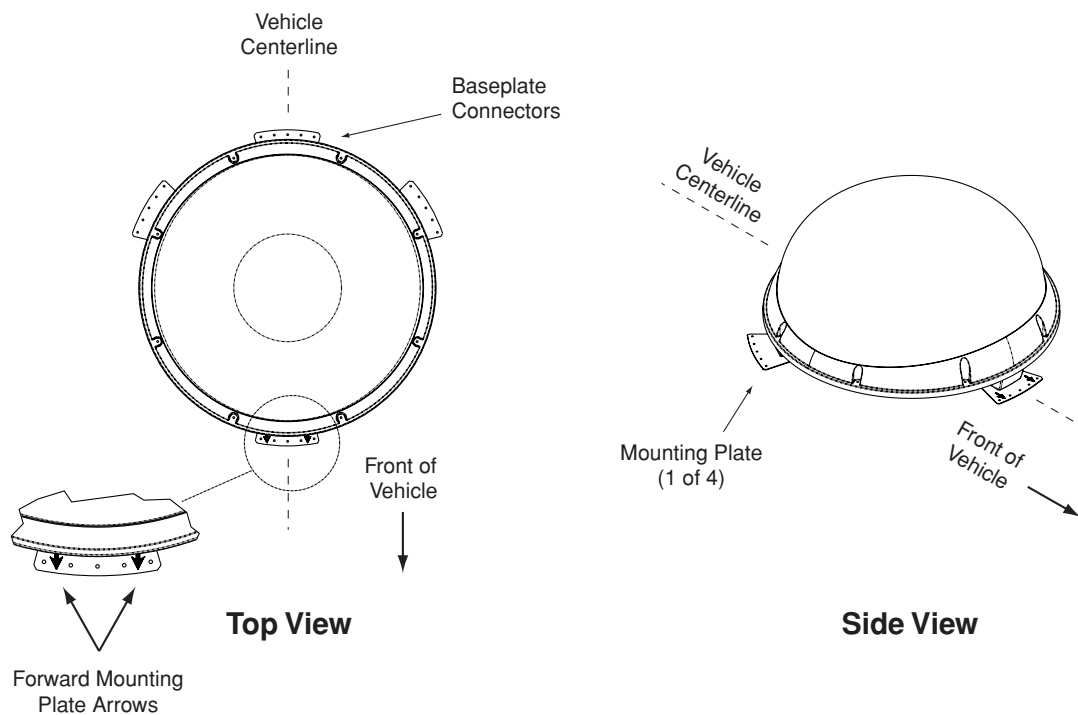

2. Place the antenna on the roof on the centerline of the vehicle so that the two arrows on the antenna's front mounting plate point toward the front of the vehicle.
3. Attach the four mounting plates to the roof using 20 $\frac{3}{16}$ "-diameter rivets (or other appropriate fasteners).
4. Seal the rivets/screws with silicone sealant (or equivalent).

5 Cut the Switchplate Mounting Hole



A full-size template has been provided for you in Appendix B.

1. Find a dry, flat location inside the vehicle within 27 feet of the antenna for mounting the switchplate. **The switchplate must be easily accessible to the user.**
2. Using the template supplied in Appendix B, cut out the switchplate mounting hole in the mounting surface.

Figure 6 Switchplate Cutout Dimensions

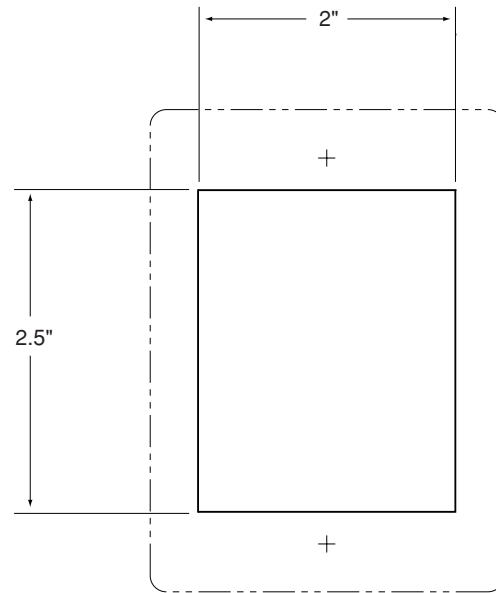

6 Wire the Antenna

1. Mark a location on the roof for the cable access hole. You will route cables from the antenna through the hole and into the vehicle.
2. Drill the $\frac{3}{4}$ " cable access hole in the location you marked in the previous step.
3. Connect the antenna data/power cable to the antenna's center connector (see Figure 7).

Figure 7 Antenna Baseplate Connectors

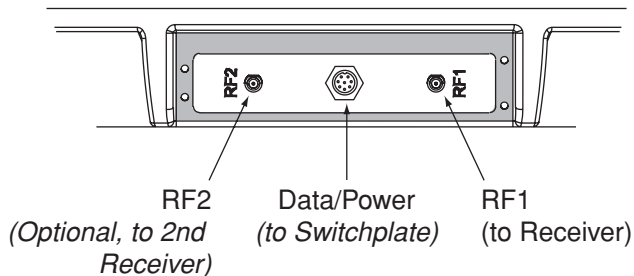

4. Connect one RF cable to the antenna's "RF1" connector. Tighten the sealing nut, found at the base of the connector, onto the end of the RF cable. If you plan to connect more than one receiver, connect a second RF cable to the "RF2" connector.
5. Route the cables down through the access hole in the roof. Be sure to maintain a service loop (approximately 8") on the roof to allow plenty of slack.
6. Route the data/power cable to the switchplate location inside the vehicle.
7. Route the RF1 cable to the primary satellite TV receiver.
8. (Optional) Route the RF2 cable to the second receiver, if applicable.



Leave the protective cap installed on the RF2 connector unless connecting a second RF cable to the TracVision LF/SF.

7 Seal the Cable Access Hole

1. Seal the cable access hole with a liberal amount of silicone sealant or RTV to protect against leakage.
2. Install the clamshell ventilator supplied in the kitpack. It must be mounted with the opening facing the rear of the vehicle over the cable access hole using three of the supplied #6 screws (see Figure 8).

Figure 8 *Installing the Clamshell Ventilator*

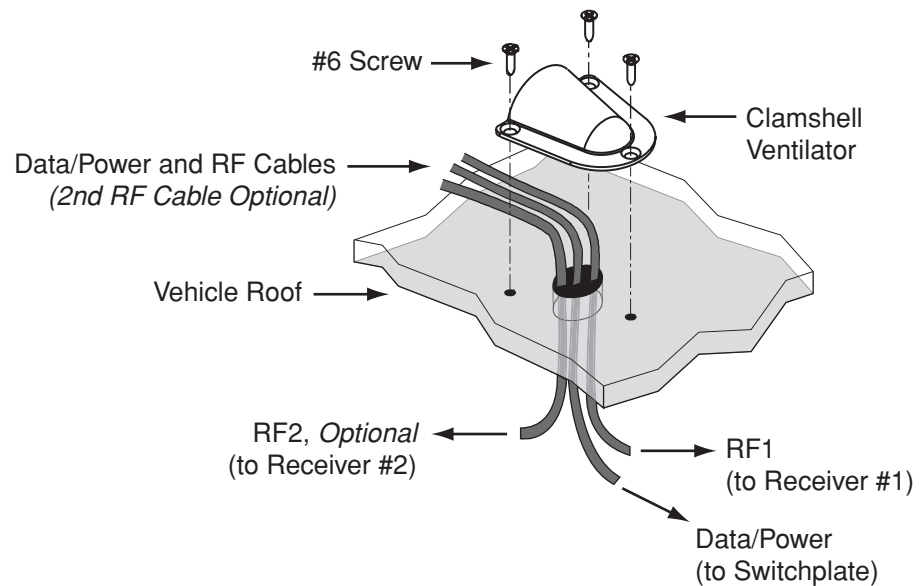

8 Wire the Receiver(s)

1. Connect the RF1 cable to the primary receiver's "Satellite In" connector (see Figure 9).

Figure 9 Receiver Rear Panel Connections (Example)

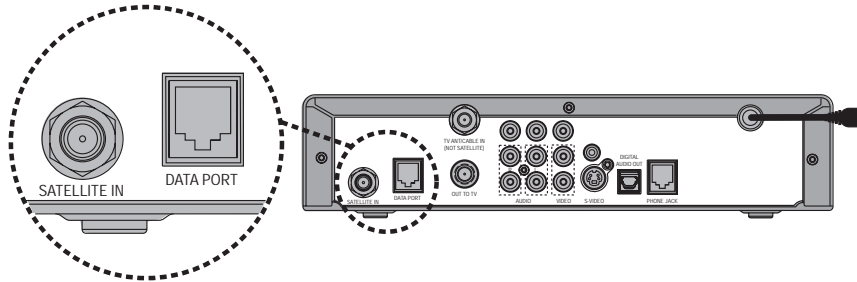

2. Connect the supplied ground wire to any screw on the receiver's rear panel. Connect the other end to a suitable ground.
3. If you need to connect two receivers, connect the RF2 cable and a second ground wire to the second receiver. If you need to connect more than two receivers, you will need to install an active multiswitch; see *Appendix A*.
4. (*DIRECTV Only*) If your primary receiver is a DIRECTV® receiver equipped with a low-speed data port, you can connect the receiver to the switchplate (see Figure 9). This allows the receiver to control satellite selection. Connect the supplied data cable (a standard RJ11 telephone handset cord) to the receiver's low-speed data port. Route the other end of the data cable to the switchplate location.

9 Wire the Switchplate

1. Connect the antenna's data/power cable to the switchplate's data/power connector and lock in place.

Figure 10 Switchplate Connections

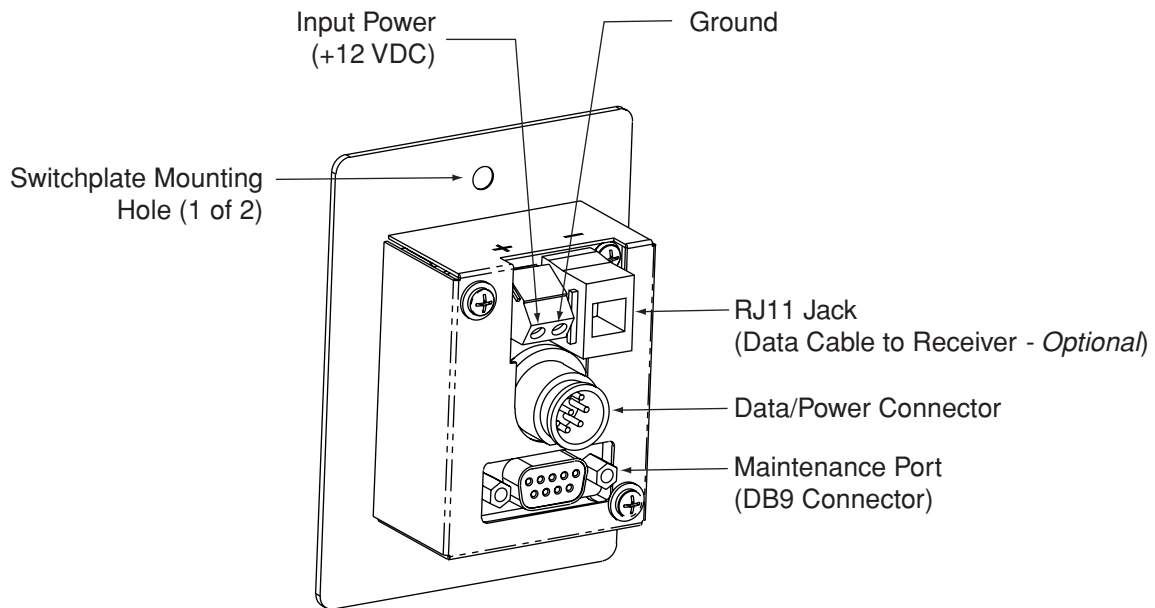

2. If you connected a data cable to a DIRECTV receiver's low-speed data port (see page 9), connect the other end of the data cable to the switchplate's RJ11 jack (see Figure 10).
3. Disconnect the vehicle's power by removing the appropriate vehicle fuse. Test the circuit to ensure that no power is present.
4. Connect the vehicle power and ground wires to the switchplate terminals (see Figure 10). **The antenna requires clean +12 VDC, 5-amp power. Therefore, KVH strongly recommends using a 12 VDC, 5-amp AC/DC power supply to power the TracVision LF/SF system.**



Before connecting vehicle power, disconnect power by removing the appropriate vehicle fuse. Test the circuit to ensure that no power is present.

10 Mount the Switchplate

1. Carefully fit the switchplate assembly into the panel cutout you created earlier (*see page 6*).
2. Secure the switchplate to the mounting surface using two supplied #6 screws (*see Figure 11*).

Figure 11 Mounting the Switchplate

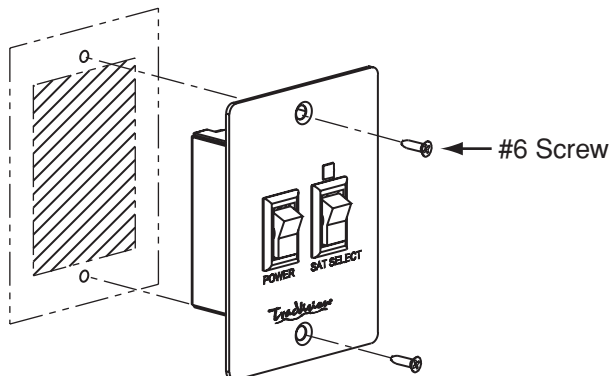

3. Reinstall the vehicle fuse you removed earlier (*see page 10*).

11 Test the System



Be sure to leave the User's Guide and Product Registration Form inside the vehicle for the customer.



The customer must activate the receiver to watch satellite TV.

To activate a **DIRECTV** receiver, call KVH at 1-888-584-4163.

To activate a **DISH Network** receiver, call 1-800-333-DISH.

To activate an **ExpressVu** receiver, call 1-888-SKY-DISH.



For information on operation, troubleshooting, and DISH 500 Configuration, please refer to the User's Guide.

Now all you need to do is turn the system on and follow the steps below to test the TracVision system.

1. Park the vehicle in a blockage-free area. The antenna requires an unobstructed view of the southern sky to receive satellite signals.
2. Turn on the receiver(s) and TV(s). For instructions on operating the receiver, refer to the receiver's owner's manual.
3. Set the switchplate's power switch to the ON (up) position (see Figure 12).

Figure 12 Switchplate Power Switch Positions

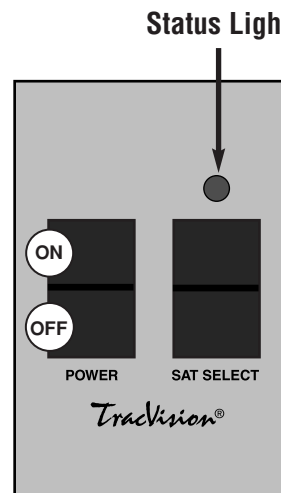

4. Wait several minutes for system startup and initial satellite acquisition.
5. Verify that a program guide appears on the TV. Only the preview channels are viewable until the customer activates the receiver. If no picture is seen, check the connections and ensure the antenna is tracking the correct satellite. See the *User's Guide* for details.
6. (*TracVision LF only*) Take a road test and verify that the antenna tracks the satellite while the vehicle is moving.
7. When you have finished testing, download the KVH Flash Wizard for free at www.kvh.com/wizard. Follow the directions on the webpage to obtain any software updates (if applicable).

Appendix A Installing 3+ Receivers

Connecting more than two receivers requires an active multiswitch (KVH part # 19-0123, Channel Master model 6214IFD, or equivalent). Install the multiswitch between the antenna unit and the receivers. Figure 13 illustrates a typical wiring arrangement for three or four receivers. *If you need to connect more than four receivers, contact KVH for additional wiring instructions.*



(DIRECTV Only) Attach the low-speed data cable to the master receiver. The master receiver must remain on for the secondary receivers to function properly.

Figure 13 Using an Active Multiswitch

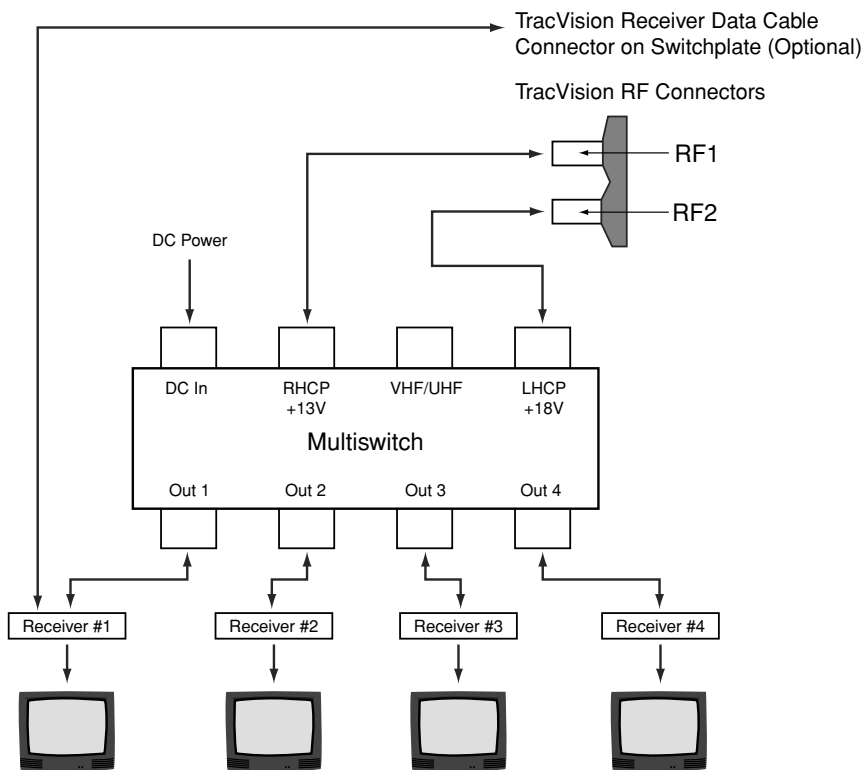

Instead of grounding individual receivers, as explained on page 9, you can simply ground the multiswitch.

Appendix B Switchplate Template

