

A Guide to TracVision L3 owner's manual

- Installation Instructions
- User's Guide
- Technical Manual



KVH TracVision® L3

TracVision L3 Owner’s Manual Addendum



(ECO #5885)

The following information applies to Revision D of the TracVision L3 Owner’s Manual (KVH Part Number 54-0157).

Your TracVision L3 includes four small mounting plates for mounting the antenna unit on a vehicle. These plates replace the large mounting plate described in the manual.

1.3 Materials Provided with TracVision L3

Table 1-3 has been updated to remove the mounting plate.

Component	KVH Part No.
Antenna Unit (comprising):	01-0225-03
Baseplate Assembly	02-1044-01
Radome Assembly	02-0953-03
RF Cable (30 ft/9 m)	32-0589-30
Power Cable (30 ft/9 m)	32-0590-30
Antenna Data Cable (30 ft/9 m)	32-0630-30
PC Cable (6 ft/1.8 m)	32-0628-06
Kitpack*	72-0101
Installation and Operation Manual	54-0157
IRD Ground Wire	32-0583-30
Switchplate	02-1023

Table 1-3
TracVision L3 Packing List



Cables for the TracVision L3 are stored beneath the antenna unit during shipping.

* A complete listing of kitpack contents is provided in [Section 2.2, “Mounting the Antenna Unit.”](#)

2.1 Choosing the Best Location

A note has been added to caution against mounting the antenna on a curved surface.

- Be sure to mount the antenna on a horizontal surface. When placed flat on the mounting surface, the mounting plates should be less than $\frac{7}{16}$ " above the mounting surface (see Figure 2-2). **Any larger gap will warp the baseplate and seriously damage the antenna.**

Figure 2-2
Maximum Mounting Surface Slope

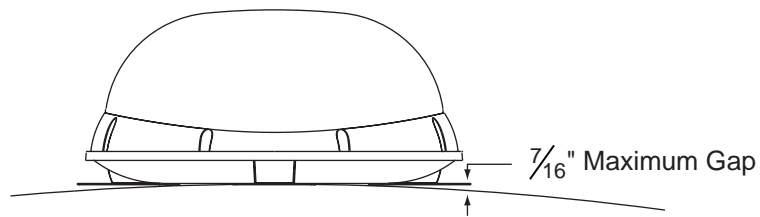

2.2 Mounting the Antenna Unit

The antenna unit mounting procedure has been changed to reflect the different mounting plates.



Always lift the antenna unit by the gray baseplate, never by the radome or any portion of the antenna assembly!

1. Make sure that you have chosen a suitable mounting location based upon the guidelines in Section 2.1, "Choosing the Best Location."
2. Remove the antenna unit from its shipping carton.
3. Position the antenna unit in the desired location on the centerline of the vehicle with the antenna's mounting plate arrows facing the front or rear of the vehicle. The proper orientation is illustrated in Figure 2-3 on the following page.

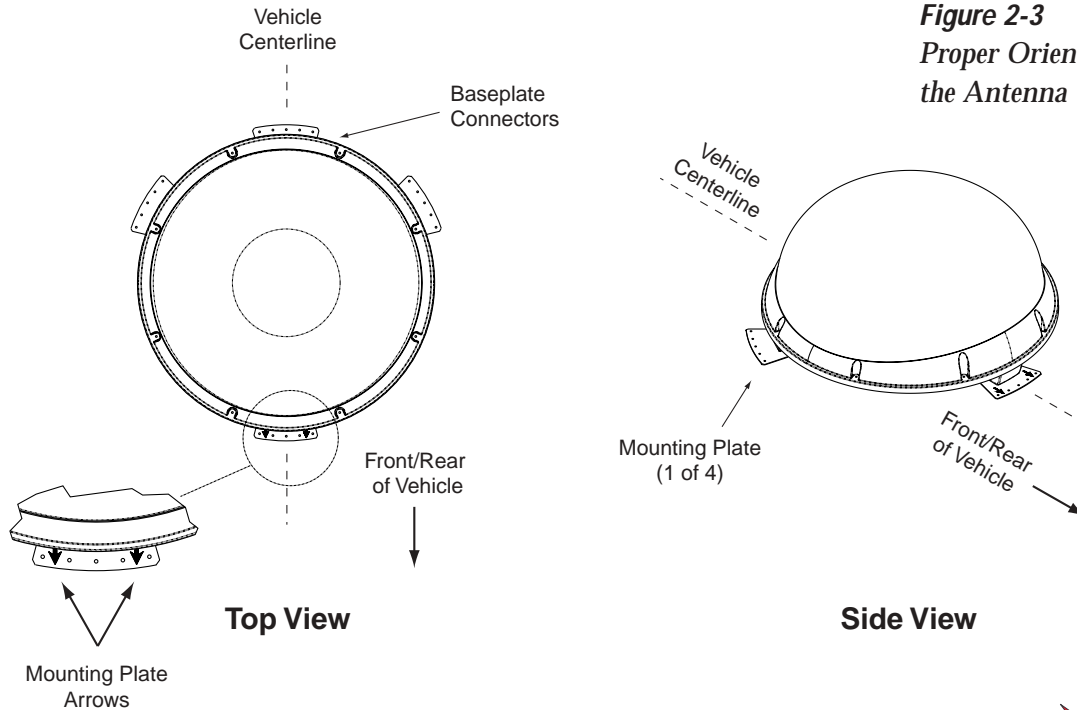

Figure 2-3
Proper Orientation of
the Antenna Unit

4. While the antenna is in place, mark a location on the roof for the cable access hole to permit convenient cable access to the antenna's baseplate connectors.
5. Using the 4 mounting plates and each set of 5 holes as templates, drill 20 $\frac{3}{16}$ " (5 mm) holes through the roof of the vehicle.
6. Set aside the antenna unit and clean the roof's surface to remove any debris.
7. Apply construction adhesive to the bottom of the antenna's four mounting plates. If using a liquid construction adhesive, apply beads to the mounting plates in a zig-zag pattern.
8. Reposition the antenna, lining up the mounting plate holes with the holes in the roof. Attach the mounting plates to the roof using $\frac{3}{16}$ " (5 mm)-diameter rivets (or appropriate fasteners). Seal all rivet heads and edges with silicone.
9. Remove and save the 8 pan head screws and flat washers that secure the radome to the baseplate. Carefully lift the radome straight up until clear of the antenna assembly and set aside.



The mounting plate arrows may face either forward or backward along the centerline of the vehicle for more convenient installation.



If the roof's mounting surface is not perfectly flat as KVH recommends, make sure the baseplate does not warp when you attach the antenna's mounting plates. Refer to Section 2.1, "Choosing the Best Location," for further details.

10. When the antenna unit is installed with the connectors facing the rear of the vehicle, the drain holes are located as shown in Figure 2-4.

Figure 2-4
Baseplate Connectors Facing Rear of Vehicle – Factory-drilled Drain Hole Locations

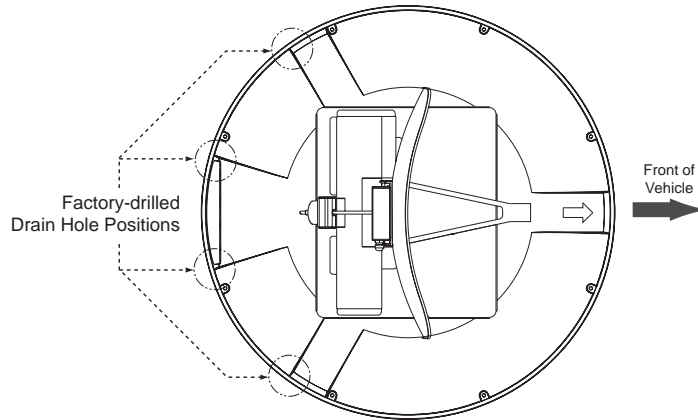

- 10a. (*Alternate Drain Hole Locations*) If the antenna unit is installed with the connectors facing the front of the vehicle, drill out $\frac{3}{16}$ " (5 mm)-drain holes in the rear-facing side of the baseplate as illustrated in Figure 2-5. The existing factory-drilled drain holes shown in Figure 2-4 must then be plugged with silicone rubber sealant.

Figure 2-5
Baseplate Connectors Facing Front of Vehicle – Recommended Drain Hole Locations



You **MUST** drill out the drain holes as indicated to ensure that any moisture that enters the baseplate is able to drain. Ensure that factory-drilled holes are completely sealed.

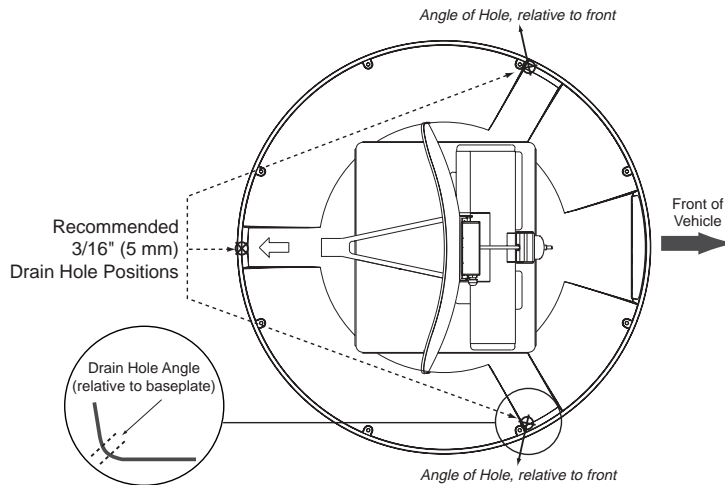

- 11. Cut the tie-wraps holding the antenna unit to the forward shipping restraint (see Figure 2-6).

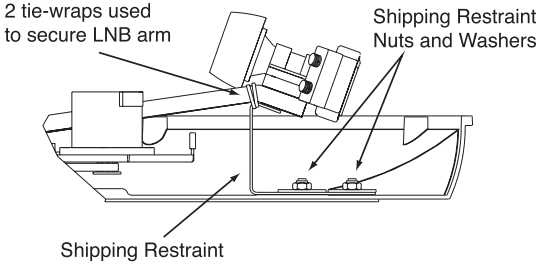

Figure 2-6
Forward Shipping Restraint (Arranged for Shipping)

- 12. Remove the nuts and washers securing the shipping restraints to the baseplate. The positions of all three shipping restraints are pictured in Figure 2-7.

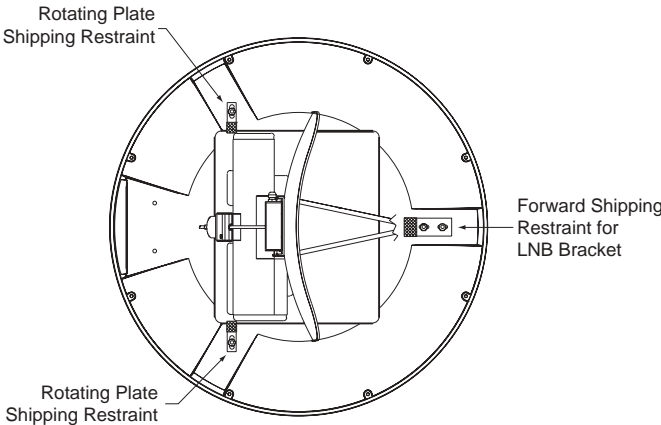

Figure 2-7
TracVision L3 Shipping Restraints (Top View, Installed for Shipping)



Do not discard the shipping restraints, washers, or the nuts. They should be stowed for future use in case the antenna unit needs to be removed and shipped to another location. Four 1/4" x 5/8" hex head screws have been provided in the kitpack for shipping as the bolts used to hold the shipping restraints during initial shipping are integral parts of the mounting plates.

- 13. For convenient storage, rotate the shipping restraints 180° and secure them to their original mounting bolts using the nuts and washers removed in Step 12 (see Figures 2-8 through 2-10). **All nuts and washers removed in Step 12 must be reinstalled. These nuts and washers secure the baseplate to the mounting plates.**

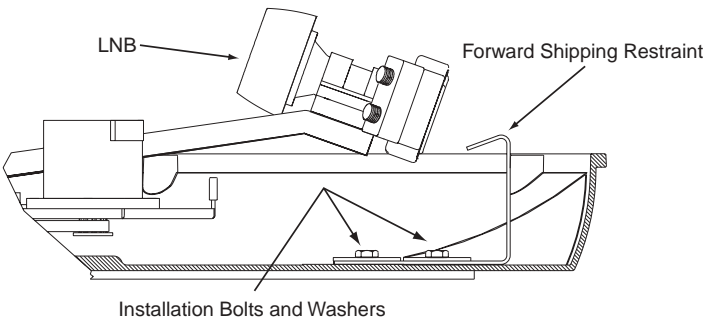

Figure 2-8
Forward Shipping Restraint Storage

Figure 2-9
*Rotating Plate Shipping
Restraint Storage*

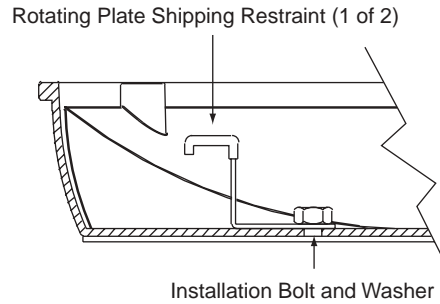
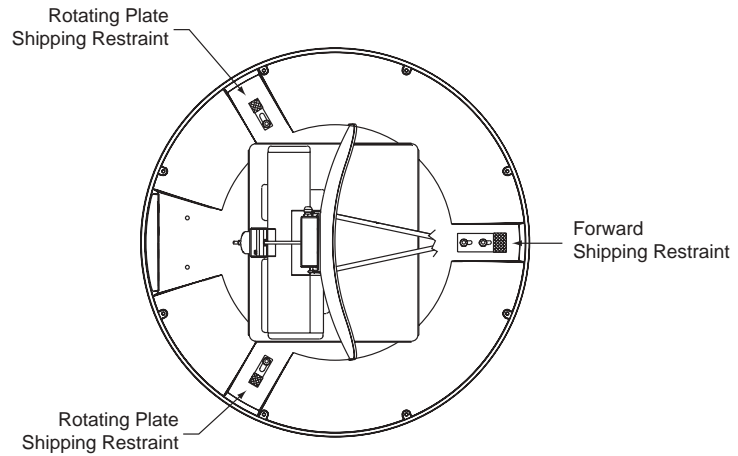

Figure 2-10
*TracVision L3 Shipping Restraints
(Storage Position)*



14. Drill the cable access hole (marked in [Step 4](#)) in the vehicle's roof.
15. Proceed to *Section 2.3, "Wiring the TracVision L3 System,"* to wire the TracVision L3 system. The radome will be placed back on the baseplate using the hardware removed in Step 9 after wiring and initializing the system.



TracVision L3 Owner's Manual Addendum

(ECO #5846)

The following information applies to Revision D of the TracVision L3 Owner's Manual (KVH Part Number 54-0157).

1.2 TracVision L3 System Overview

The baseplate connectors have been changed to make installation easier. Figure 1-1 shows the new baseplate connectors and cable routing.

Figure 1-1
TracVision L3 System Configuration

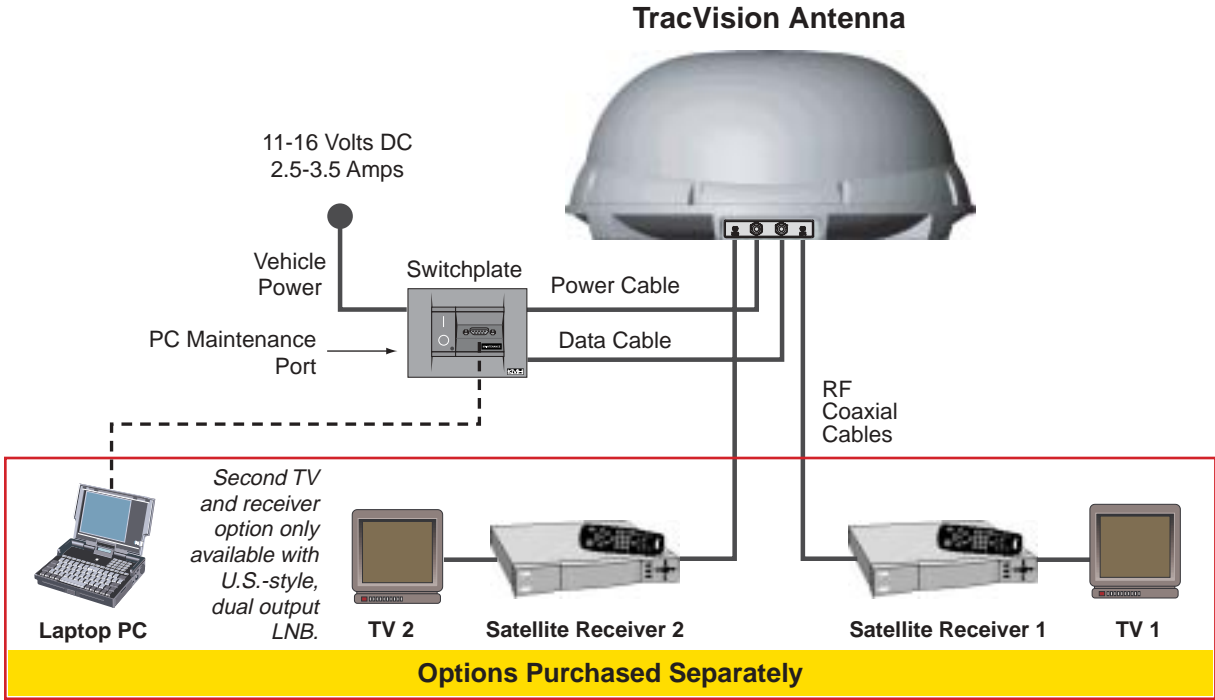

2.3 Wiring the TracVision L3 System

The baseplate connectors have been changed to make installation easier.

TracVision L3 Cable Ports

Figure 2-14 shows the antenna unit's exterior baseplate cable ports, consisting of two RF connectors (ports #1 and #4) and two liquid-tight fittings (ports #2 and #3). Figure 2-15 shows the interior baseplate wiring. Refer to these figures when connecting cables to the antenna unit.

Figure 2-14
Cable Port Assignments
(Exterior of Baseplate)

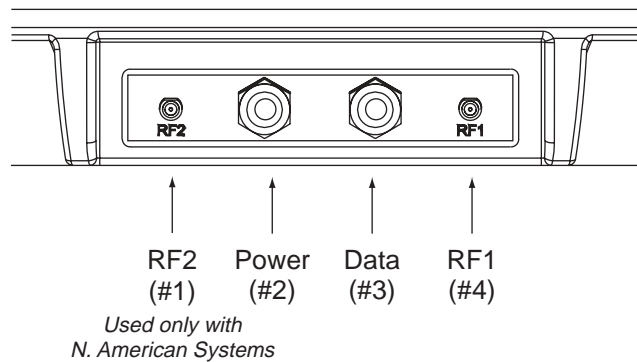
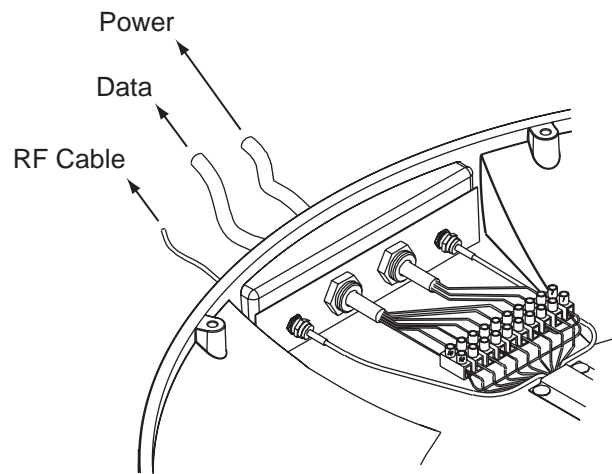

Figure 2-15
Interior Baseplate Wiring



2.3.1 Wiring the Antenna Data Cable

The data cable now enters the baseplate through the second liquid-tight fitting (cable port #3). Interior baseplate wiring is unchanged.

Antenna Data Cable-to-Baseplate Terminals Wiring Process

1. Feed the cable up to the roof and through the second liquid-tight fitting (#3) as pictured in Figure 2-14.

2.3.2 Wiring the Antenna Unit Power Cable

The power cable now enters the baseplate through the first liquid-tight fitting (cable port #2). Interior baseplate wiring is unchanged.

Power Cable-to-Baseplate Terminals Wiring Process

1. Feed the cable up to the roof and through the first liquid-tight fitting (#2) as pictured in Figure 2-14.

2.3.6 Connecting the Antenna RF Signal Cable to the IRD

You no longer need to insert RF cables into the baseplate; they now simply connect to the exterior baseplate connectors.

The RF signal cable is fitted with an F-type connector at only one end and should be attached to TracVision L3 and the IRD as follows:

1. For a single IRD installation, connect the F-connector end of the RF signal cable to the Antenna Unit baseplate connector labeled RF1 (see Figure 2-14). Once the cable is securely connected, loosen the sealing nut at the base of the RF1 connector and tighten it onto the end of the RF cable.
2. Feed the bare end of the RF signal cable through the cable access hole and into the vehicle.
3. Attach the provided F-connector to the end of the RF signal cable inside the vehicle as illustrated in Figure 2-24a-d, using an Augat Snap 'n Seal Crimp/Strip tool to lock the connector on the cable.
 - A. Slide compression fitting onto raw cable before beginning connector termination.

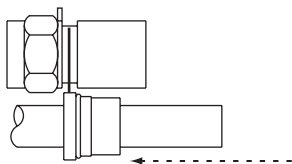

When shipped from the factory, the antenna's RF connectors are protected with caps. Leave the cap installed on the RF2 connector unless you are going to connect a second RF cable to the TracVision L3.

Figure 2-24a-d

Attaching the KVH-provided F-connector to an RF Cable



KVH has provided an F-connector for use with the TracVision L3. This connector specifically requires the Augat Snap 'n Seal Crimp/Strip Tool, part number IT1000.

If you do not have this tool, you will need to purchase a silicone-filled, weatherproof F-connector (Radio Shack part number 278-236 or equivalent) to use instead.

- B. Twist and break off connector body.

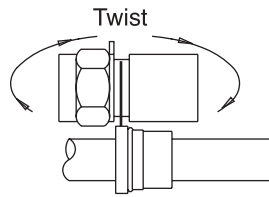

- C. Use the Augat tool to strip the center conductor and trim back the overall jacket. Do not cut through the braid.

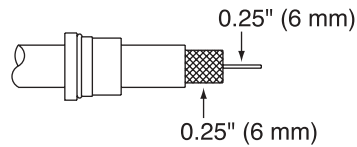

- D. Slide connector body onto the prepared cable. Slide the compression fitting up into the connector body. Use Augat tool to snap on the connector.

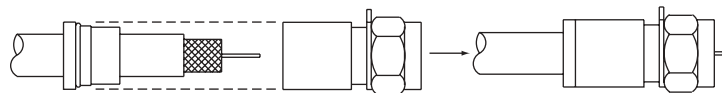

4. Attach the cable to the IRD connector labeled SATELLITE IN.

2.3.6.1 Installing Two IRDs and TVs (North American Systems Only)

To connect a second TV and IRD to the TracVision L3 system, you must connect a second RF cable to the Antenna Unit baseplate connector labeled RF2. The other end of the RF cable should be run down into the vehicle and connected directly to the second IRD. Each IRD/TV pair can operate independently of the other, allowing different viewers to watch different channels.

TracVision L3 Owner's Manual Addendum



(ECO #s 5382, 5426)

The following information applies to Revision D of the TracVision L3 Owner's Manual (KVH Part Number 54-0157).

5.3 Replaceable Parts

Due to system improvements, the TracVision L3 now consumes less power. As a result, the system fuse has been changed from a 4-amp to a 3.15-amp fuse.

Part Name	Part Number
Baseplate Assembly	02-1044-01
Radome Assembly	02-0953-03
Power Cable	32-0590-30
Antenna Data Cable	32-0630-30
RF Cable	32-0589-30
PC Cable	32-0628-06
CPU PCB	02-1043-02
RF PCB	02-1017-02
Antenna Gyro	02-1035
Antenna Gyro Gasket	24-0139
System Fuse	16-0017-3150
LNB (European System)	19-0196
LNB (N. American System)	19-0056
Switchplate	02-1023

Table 5-1
Field Replaceable Units



*Should the fuse ever need to be replaced, TracVision L3 uses a 5x20 mm, **3.15-amp**, 250-volt fast-blow fuse.*

5.4 Field Replaceable Unit Procedures

The elevation axis motor shaft bracket has been redesigned for simplicity, allowing easier access to the printed circuit board (PCB). This new configuration requires minor changes to the procedure for removing and replacing the PCB.

Figure 5-2
Close-up of Connecting Rod
and E-ring

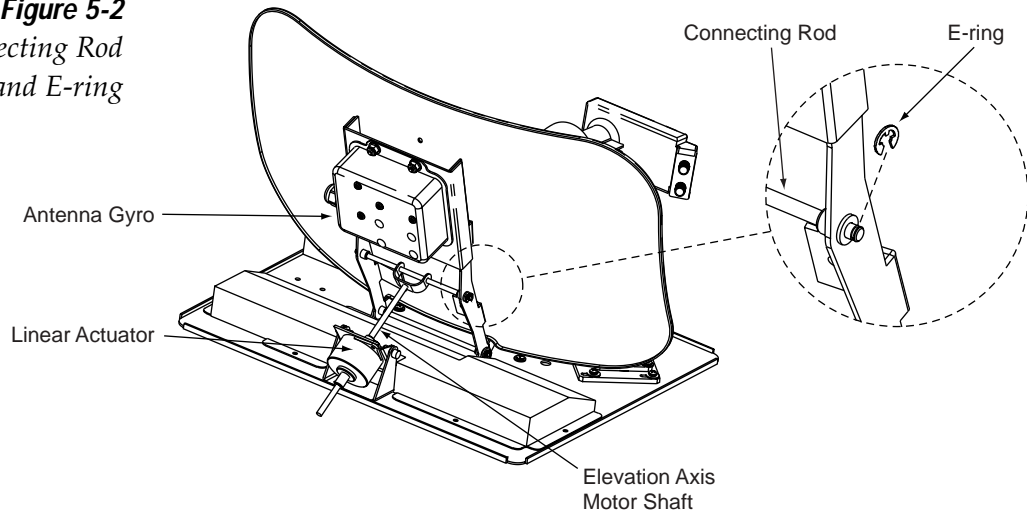

5.4.1 PCB Removal and Replacement

Estimated Time to Repair: ½ hour



When carrying out maintenance on the PCB, be sure to not drop any of the small screws inside the mechanism. If a screw is lost within the baseplate, it must be retrieved to avoid causing any damage when the unit rotates.

The microprocessor PCB assembly is protected by a cover fastened to the rotating plate – Fig. 5-1. The cover must be removed to gain access to the main power fuse and the PCB assembly.

1. Using needle-nose pliers, remove the E-ring from one end of the connecting rod – Fig. 5-2.
2. Remove the connecting rod by sliding it off the bracket.
3. Fully retract the elevation axis motor shaft – Fig. 5-5.

Figure 5-5
Removing the PCB Cover

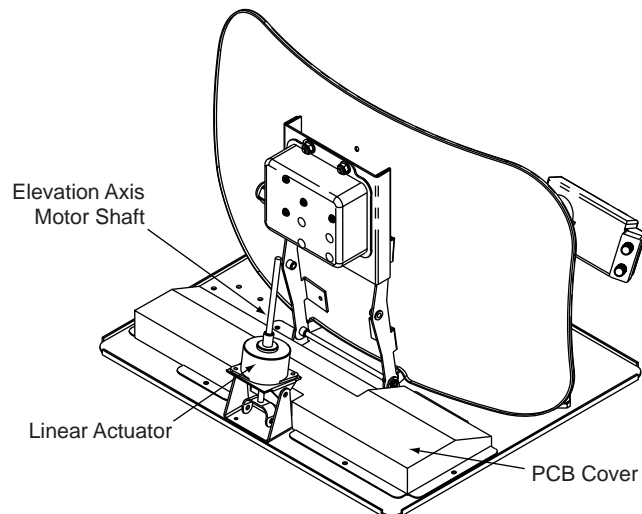

4. Remove 6 pan head screws from the PCB cover flanges.
5. Remove the PCB cover. To get the necessary clearance, rotate the linear actuator up 90° while lifting the PCB cover – Fig. 5-5.
6. Remove cable connectors from PCB. Figure 5-6 illustrates the PCB arrangement and connector locations.



TracVision L3 is equipped with a 5x20 mm, **3.15-amp**, 250-volt fast-blow fuse, which is mounted on the PCB. To access and replace the fuse, remove the PCB cover.

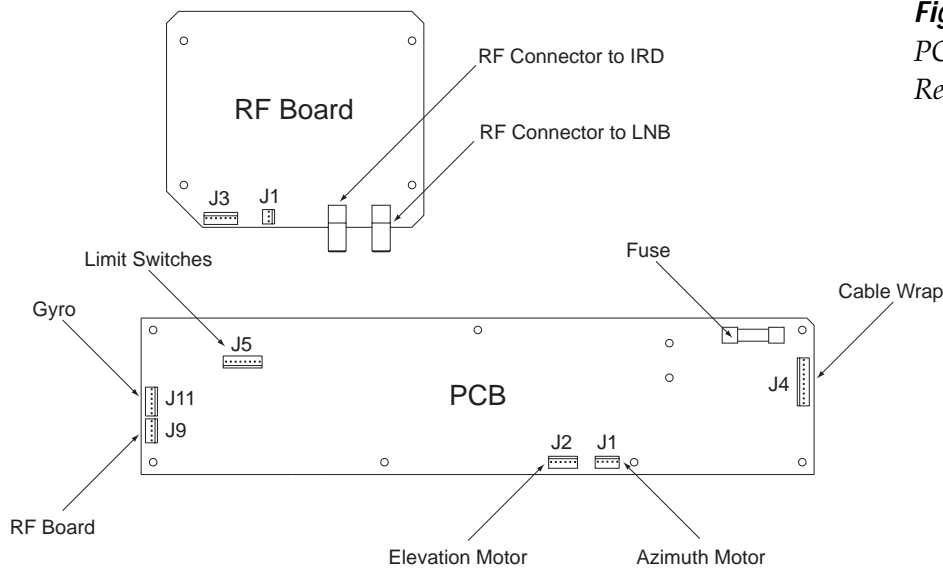

Figure 5-6
PCB Connector Locations – Rear View

7. The PCB is mounted to the rotating plate with 9 pan head screws. Remove the screws and PCB.
8. Reverse this process to install the replacement PCB. Reinstall all cable connectors removed in Step 6.
9. Carry out all calibration procedures for the antenna gyro (Section 5.4.3).
10. Reinstall your preferred satellites as detailed in Section 2.4.1, "Installing Your Selected Satellites."



When replacing the PCB cover, be careful not to pinch any cables.



Following the removal and replacement of the antenna gyro assembly, it will be necessary to calibrate the gyro and restart the system.

5.4.3 Antenna Gyro Assembly

Estimated Time to Repair: 1 hour

The antenna gyro is mounted on the rear of the antenna reflector bracket with four locking nuts and washers – *Fig. 5-3*. Following the removal and replacement of the antenna gyro assembly, it will be necessary to calibrate the gyro and restart the system. Directions for removal, replacement, and calibration follow:

1. Using needle-nose pliers, remove the E-ring from one end of the connecting rod – *Fig. 5-2*.
2. Remove the connecting rod by sliding it off the bracket.
3. Fully retract the elevation axis motor shaft – *Fig. 5-5*.
4. Remove 6 pan head screws from the PCB cover flanges.
5. Remove the PCB cover. To get the necessary clearance, rotate the linear actuator up 90° while lifting the PCB cover – *Fig. 5-5*.
6. Remove the screw and clamp holding the antenna gyro cable to the rotating plate. Be sure to save the cable clamp and screw – *Fig. 5-4*.
7. Remove the Molex connector from J11 on the PCB – *Fig. 5-6*.
8. Remove the 4 nuts and washers and take the gyro off of the bracket.
9. Remove the antenna gyro gasket.
10. Replacement is the reverse of this procedure.

TracVision L3 Owner's Manual Addendum



(ECO #5426)

The following information applies to Revision D of the TracVision L3 Owner's Manual (KVH Part Number 54-0157).

5.3 Replaceable Parts

Due to system improvements, the TracVision L3 now consumes less power. As a result, the system fuse has been changed from a 4-amp to a 3.15-amp fuse.

Part Name	Part Number
Baseplate Assembly	02-1044-01
Radome Assembly	02-0953-03
Power Cable	32-0590-30
Antenna Data Cable	32-0630-30
RF Cable	32-0589-30
PC Cable	32-0628-06
CPU PCB	02-1043-02
RF PCB	02-1017-02
Antenna Gyro	02-1035
Antenna Gyro Gasket	24-0139
System Fuse	16-0017-3150
LNB (European System)	19-0196
LNB (N. American System)	19-0056
Switchplate	02-1023

Table 5-1

Field Replaceable Units



Should the fuse ever need to be replaced, TracVision L3 uses a 5x20 mm, **3.15-amp**, 250-volt fast-blow fuse.



TracVision L3 is equipped with a 5x20 mm, **3.15-amp**, 250-volt fast-blow fuse, which is mounted on the PCB. To access and replace the fuse, follow the directions to remove the PCB cover and then swap the blown fuse for a new one.

5.4.1 PCB Removal and Replacement

The sidebar note has been changed to indicate the new rating of the fuse.

TracVision L3 Owner's Manual Addendum



(ECO #5385)

The following information applies to Revision D of the TracVision L3 Owner's Manual (KVH Part Number 54-0157).

2.2 Mounting the Antenna Unit

Since the flash kit cable and adapter are unnecessary to fully operate the system, they have been removed from the TracVision L3 kitpack.

Table 2-2 has been changed to reflect this deletion.

Part	Qty.	KVH Part No.
RF F-Connector	1	23-0170
Tie-wrap	5	22-0013
Clam Shell Ventilator	1	19-0230
¼"-20 x ⅝" hex screws	4	14-0250-0010
¼" flat washers	4	14-0251

Table 2-2
Kitpack Contents

Congratulations!

You have selected one of the most advanced land-mobile satellite tracking systems available today. KVH® Industries' TracVision® L3 is designed for use with European and North American DVB-compatible satellite services as well as **DIRECTV®**. This manual provides detailed instructions on the proper installation, use, and maintenance of your TracVision L3 system.

Throughout this manual, important information is marked for your attention by these icons:



A helpful tip that either directs you to a related area within the manual or offers suggestions on getting the highest quality out of your system.



An alert to important information regarding procedures, product specifications, or product use.



Information about installation, maintenance, troubleshooting, or other mechanical issues.



An electrical safety warning to help identify electrical issues that can be a hazard to either this KVH product or a user.

Direct questions, comments, or suggestions to:

KVH Industries, Inc.
50 Enterprise Center
Middletown, RI 02842 USA
Tel: +1 401 847-3327
Fax: +1 401 849-0045
E-mail: info@kvh.com
Internet: www.kvh.com

KVH Europe A/S
Ved Klaedebo 12
2970 Hoersholm Denmark
Tel: +45 45 16 01 80
Fax: +45 45 86 70 77
E-mail: info@kvh.dk
Internet: www.kvh.com



The Quality Advantage

Click here to go to our state-of-the-art Customer Support web page...the fastest and easiest way to get all of your questions answered!



KVH Part # 54-0157 Rev. D
© 2001, KVH Industries, Inc.

TracVision® and KVH® are registered trademarks of
KVH Industries, Inc.

DIRECTV® is an official trademark of DIRECTV, Inc.,
a unit of GM Hughes Electronics.

DISH Network™ is an official trademark of
EchoStar Communications Corporation.

ExpressVu is a property of Bell ExpressVu, a wholly owned
subsidiary of Bell Satellite Services.

Table of Contents

- 1 Introduction1-1**
- 1.1 Digital Satellite Television1-1**
- 1.2 TracVision L3 System Overview1-2**
 - 1.2.1 TracVision L3 Components1-3
 - 1.2.2 Integrated Receiver Decoder1-4
- 1.3 Materials Provided with TracVision L31-4**
 - 1.3.1 Additional Materials required for TracVision L3 Use1-5

- 2 Installation2-1**
- 2.1 Choosing the Best Location2-2**
- 2.2 Mounting the Antenna Unit2-2**
- 2.3 Wiring the TracVision L3 System2-8**
 - 2.3.1 Wiring the Antenna Data Cable2-10
 - 2.3.2 Wiring the Antenna Unit Power Cable2-11
 - 2.3.3 Connecting to Vehicle Power2-12
 - 2.3.4 Connecting the IRD Ground Wire2-13
 - 2.3.5 Installing the Switchplate2-13
 - 2.3.6 Connecting the Antenna RF Signal Cable to the IRD2-14
 - 2.3.6.1 Installing Two IRDs and TVs (North American Systems Only)2-15
 - 2.3.6.2 Connecting Three or More IRDs and TVs (North American Systems Only)2-15
- 2.4 Selecting the Active Satellite2-17**
 - 2.4.1 Installing Your Selected Satellites2-18
 - 2.4.2 Programming User-defined Satellites2-20
- 2.5 Setting the Skew Angle (European Systems Only)2-24**
- 2.6 Checking Out the System2-24**
- 2.7 Configuring TracVision L3 for Remote Satellite Dish Operation2-26**
- 2.8 Changing Geographic Location2-27**

3	Using Your TracVision L3	3-1
3.1	Turning on the System	3-1
3.2	Changing Channels and Switching to the Second Satellite	3-2
3.3	Watching TV on the Move and at Rest	3-3
4	Troubleshooting	4-1
4.1	Causes and Remedies for Common Operational Issues	4-1
4.1.1	Blown Fuse or Improper Wiring	4-2
4.1.2	Incorrect Satellite Configuration	4-2
4.1.3	Satellite Signal Blocked	4-2
4.1.4	Dew or Rain Pooling on Dome	4-3
4.1.5	Outside Satellite Coverage Zone	4-3
4.1.6	Vehicle Turning During Startup	4-3
4.1.7	Incorrect or Loose RF Connectors	4-3
4.1.8	Using a Passive Multiswitch (North American Systems Only)	4-4
4.2	IRD Troubleshooting	4-4
4.2.1	IRD Wiring	4-4
4.2.2	IRD Faulty	4-4
4.3	Antenna Gyro and LNB Faults	4-4
4.4	Computer Diagnostics	4-4
4.5	Maintenance Port Parser Commands	4-5
5	Maintenance	5-1
5.1	Warranty/Service Information	5-1
5.2	Preventive Maintenance	5-1
5.3	Replaceable Parts	5-2
5.4	Field Replaceable Unit Procedures	5-3
5.4.1	PCB Removal and Replacement	5-5
5.4.2	RF Detector/DVB Decoder	5-6
5.4.3	Antenna Gyro Assembly	5-6
5.4.4	Antenna LNB Replacement	5-7

5.5	Preparation for Shipment	5-8
Appendix A	System Specifications	A-1
Appendix B	Functional Block Diagram	B-1
Appendix C	Switchplate Template	C-1
Appendix D	Predefined Satellite Configurations	D-1
Appendix E	Startup Data Sequence	E-1
Appendix F	Maintenance Port Parser Commands	F-1
F.1	System Commands	F-1
F.2	Manual Positioning Commands	F-2
F.3	Operational Commands	F-4
F.4	Tracking and Conical Scan Commands	F-4
F.5	RF Board Commands	F-5
F.6	Installation Commands	F-6
F.7	Debug Commands	F-8

List of Figures

Figure 1-1	TracVision L3 System Configuration	1-2
Figure 1-2	Primary Components of the TracVision L3	1-3
Figure 2-1	Antenna Blockage	2-2
Figure 2-2	Proper Orientation of the Antenna Unit	2-3
Figure 2-3	Forward Shipping Restraint (Arranged for Shipping)	2-3
Figure 2-4	TracVision L3 Shipping Restraints (Top View, Installed for Shipping)	2-4
Figure 2-5	Mounting the Unit on a Curved Surface	2-4
Figure 2-6	Mounting Plate Dimensions	2-5
Figure 2-7	Connectors Facing Rear of Vehicle – Factory-drilled Drain Hole Locations	2-6

Figure 2-8	Connectors Facing Front of Vehicle – Recommended Drain Hole Locations	2-6
Figure 2-9	Forward Shipping Restraint Storage	2-7
Figure 2-10	Rotating Plate Shipping Restraint Storage	2-7
Figure 2-11	TracVision L3 Shipping Restraints (Storage Position)	2-7
Figure 2-12	Proper Wire-to-Terminal Connection	2-8
Figure 2-13	Moving the Antenna Reflector	2-8
Figure 2-14	Cable Port Assignments (Exterior of Baseplate)	2-8
Figure 2-15	Cable Overlap within the TracVision L3 Baseplate	2-9
Figure 2-16	Switchplate Panel Cutout Dimensions	2-9
Figure 2-17	Proper Terminal Strip Wiring Arrangement – Data Cable	2-10
Figure 2-18	Antenna Data Cable Wiring Arrangement	2-11
Figure 2-19	Proper Terminal Strip Wiring Arrangement – Power Cable	2-11
Figure 2-20	Power Cable Wiring Arrangement	2-12
Figure 2-21	Vehicle Power Wiring Arrangement	2-12
Figure 2-22	Mounting the Switchplate Support Frame and Front Cover	2-13
Figure 2-23	Connecting the RF Cable to TracVision L3	2-14
Figure 2-24a-d	Attaching the KVH-provided F-connector to an RF Cable	2-14
Figure 2-25	Installing Three or More IRDs Using an Active Multiswitch (North American Systems Only)	2-16
Figure 2-26	Skew Adjustment (European Systems Only)	2-24
Figure 2-27	Remote Dish Wiring Configuration	2-26
Figure 3-1	Be Aware of Objects that Might Block the Satellite Signals	3-1
Figure 3-2	Turning on the TracVision L3 Using the Switchplate	3-1
Figure 5-1	Antenna, PCB, and Rotating Plate	5-3
Figure 5-2	Close-up of Linear Actuator, Pivot Bracket, and Pin	5-3
Figure 5-3	Antenna Assembly	5-4
Figure 5-4	Close-up of RF Detector and PCB	5-4

Figure 5-5	PCB and RF Detector Board Connector Locations	5-5
Figure 5-6	LNB Skew Angle Setting (European Systems Only)	5-7
Figure 5-7	Attaching the Shipping Restraints to the Antenna Baseplate	5-8
Figure 5-8	Securing the Forward Shipping Restraint	5-9
Figure 5-9	Repackaging the TracVision L3	5-9

List of Tables

Table 1-1	Available European Satellite Pairs (European LNB Required)	1-1
Table 1-2	Available N. American Satellite Pairs (U.S.-style LNB required)	1-2
Table 1-3	TracVision L3 Packing List	1-4
Table 2-1	Installation Process	2-1
Table 2-2	Kitpack Contents	2-2
Table 2-3	Available European Satellite Pairs (European LNB Required)	2-17
Table 2-4	Available N. American Satellite Pairs (U.S.-style LNB Required)	2-17
Table 2-5	Satellite Installation Names	2-19
Table 2-6	Default Transponder Values	2-22
Table 2-7	Sample User-defined Satellite Configuration	2-23
Table 2-8	LNB Part Numbers	2-27
Table 4-1	Troubleshooting Matrix	4-1
Table 5-1	Field Replaceable Units	5-2
Table A-1	TracVision L3 System Specifications	A-1
Table F-1	System Commands	F-1
Table F-2	Manual Positioning Commands	F-2
Table F-3	Operational Commands	F-4
Table F-4	Tracking and Conical Scan Commands	F-4
Table F-5	RF Board Commands	F-5
Table F-6	Installation Commands	F-7
Table F-7	Debug Commands	F-8

1 Introduction

1.1 Digital Satellite Television

Your new TracVision L3 satellite antenna is fully compatible with the Digital Video Broadcasting (DVB) satellites, which use the international standard for digital TV transmission, as well as Digital Satellite Service (DSS) services, such as DIRECTV®. As a result, you will be able to receive and decode signals from your chosen satellite services with the proper programming and hardware (e.g., the Integrated Receiver Decoder [IRD]). Your TracVision L3 comes with a pre-programmed “satellite library” of European and North American satellite services. If the satellite service you wish to receive is not already in the “satellite library,” you may also add two additional satellites of your choice to the library.

When configuring the TracVision L3 you may choose a pair of satellites from the entire library to be active in the system and with your IRD. Selecting one satellite or the other is as simple as changing the television channel using the IRD remote control. For the antenna to track and receive signals from two satellites, they must be within 10° longitude of each other in orbit. As a result, certain satellites can be paired only with certain other satellites. Tables 1-1 and 1-2 list the possible satellite pairs that may be selected in Europe and in North America.



TracVision L3's default satellite pairs are:

Europe: Astra 1 & Hotbird

*N. America (US DIRECTV):
DSS_101 & DSS_119*

or

*N. America (US DISH Network):
Echo_119 & None*

Refer to Section 2.4, “Selecting the Active Satellite,” for instructions on selecting different satellites.

Table 1-1
*Available European Satellite Pairs
(European LNB Required)*

	Astra 1	Astra 2N	Astra 2S	Hispasat	Hotbird	Sirius	Thor
Astra 1		✓	✓		✓	✓	
Astra 2N	✓				✓		
Astra 2S	✓				✓		
Hispasat							
Hotbird	✓	✓	✓			✓	
Sirius	✓				✓		✓
Thor						✓	

Table 1-2

Available N. American Satellite Pairs (U.S.-style LNB required)

	DSS_101	DSS_110	DSS_119	Echo_61	Echo_110	Echo_119	Echo_148	Expressvu
DSS_101			✓					
DSS_110*								
DSS_119	✓							
Echo_61					✓	✓		✓
Echo_110				✓		✓	✓	✓
Echo_119				✓	✓		✓	✓
Echo_148					✓	✓		✓
Expressvu				✓	✓	✓	✓	

* Contact KVH or DIRECTV for complete details on tracking and receiving signals from DSS_110.

1.2 TracVision L3 System Overview

Your TracVision L3 employs a state-of-the-art actively stabilized antenna system. Once the satellite is acquired, the antenna gyro continuously measures your vehicle's motion and position, and transmits commands to the antenna motors to keep the antenna pointed at the satellite at all times. A complete satellite TV system includes the TracVision L3 connected to an IRD, and a television set. A desktop or laptop computer is used to configure the system for satellite selection and conduct diagnostics. The system is illustrated in Figure 1-1.

Figure 1-1
TracVision L3 System Configuration

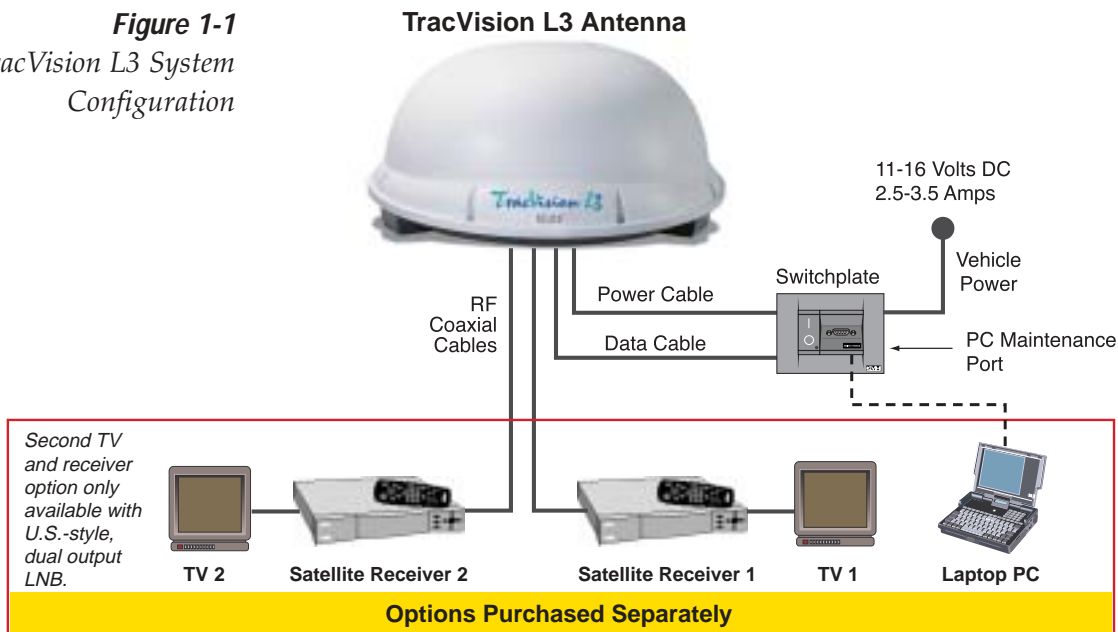

System specifications and a functional block diagram are provided in *Appendices A* and *B*, respectively.

1.2.1 TracVision L3 Components

The Antenna Unit includes the antenna positioning mechanism, signal front end, power supply and control elements. The antenna is a parabolic dish mounting a low noise block (LNB) converter with built-in preamplifier. The European configuration includes a single port LNB while the North American system uses a dual-output LNB. A molded ABS radome encloses the fiberglass baseplate and is secured in place with standard fasteners. Liquid-tight (watertight) fittings located on the back of the baseplate join the power, signal, and control cabling from units inside the vehicle.

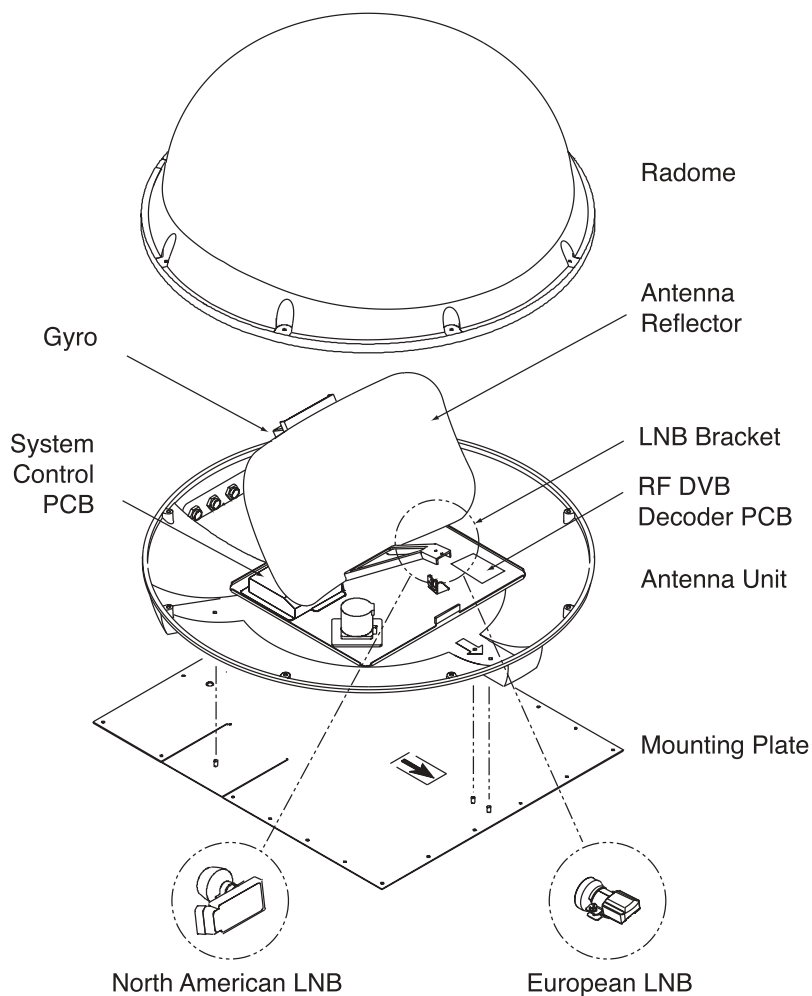

Figure 1-2
Primary Components of the
TracVision L3



Always lift the Antenna Unit by the gray baseplate and not the radome, antenna reflector, or internal mechanical assemblies.

NEVER pick up the unit by the LNB or the gyro!



The dual-output LNB in the North American systems allows two IRD/TV pairs to be connected directly to the antenna. Three or more pairs can be connected to the system if an active multiswitch is used. [Section 2.3.6, “Connecting the Antenna RF Signal Cable to the IRD,”](#) provides installation directions for each of these options.

1.2.2 Integrated Receiver Decoder

The IRD (purchased separately) receives satellite signals from the Antenna Unit for signal processing and channel selection, and sends the signals to the TV set for viewing. The IRD also provides the interface for the user to activate authorization for reception. Please refer to the User’s Manual provided with your selected IRD for complete operating instructions.

1.3 Materials Provided with TracVision L3

Table 1-3 lists the units, cables, and materials packed in the TracVision L3 package by name and KVH part number.

Table 1-3
TracVision L3 Packing List



Cables for the TracVision L3 are stored beneath the Antenna Unit during shipping.

Component	KVH Part No.
Antenna Unit (comprising):	01-0225-03
Baseplate Assembly	02-1044-01
Radome Assembly	02-0953-03
RF Cable (30 ft/9 m)	32-0589-30
Power Cable (30 ft/9 m)	32-0590-30
Antenna Data Cable (30 ft/9 m)	32-0630-30
PC Cable (6 ft/1.8 m)	32-0628-06
Mounting Plate	20-0668
Kitpack*	72-0101
Installation and Operation Manual	54-0157
IRD Ground Wire	32-0583-30
Switchplate	02-1023

* A complete listing of kitpack contents is provided in [Section 2.2, “Mounting the Antenna Unit.”](#)

1.3.1 Additional Materials Required for TracVision L3 Use

To make full use of your new TracVision L3 and receive satellite TV on the road, you will need to provide/purchase the following:

- Television
- Appropriate IRD for your selected satellite TV service, and
- Sealing materials to weatherproof cable holes and seal mounting plate.

2 Installation

TracVision L3 is designed for simple installation and setup. Just follow these easy steps:

Step	Refer to Section...
1. Choose the hardware locations	2.1
2. Mount the Antenna Unit	2.2
3. Wire system components	2.3
4. Select active satellite	2.4
5. Set the skew angle (Europe only)	2.5
6. Check out system	2.6
7. Configure for remote dish use	2.7

Table 2-1

Installation Process



Plan the entire installation before proceeding! Take into account component placement, running cable distances between units, and accessibility to the equipment after installation.

Installation Tools and Materials Required

- Electric drill
- $\frac{3}{16}$ " (5 mm) and $\frac{3}{32}$ " (2 mm) drill bits and $\frac{1}{2}$ " (13 mm) hole saw and auger bit
- $\frac{1}{2}$ " socket wrench
- #2 Phillips and #0 flat tip screwdrivers
- Augat Snap 'n Seal Crimp/Strip Tool (Part Number IT1000) if using the KVH-provided F-connector
- Silicone sealant, RTV, or Sikaflex
- Thread locker (as required)
- $\frac{7}{16}$ " open end wrench
- Wire strippers
- Construction adhesive (e.g., Liquid Nails)
- Rivet gun and $\frac{3}{16}$ " (5 mm) rivets (or other fastener suitable for your specific roof construction)
- PC with terminal emulation software such as PROCOMM, Windows Terminal, or Windows 95/98 Hyperterminal



Always lift the Antenna Unit by the gray baseplate, never by the radome or any portion of the antenna assembly!

Figure 2-1
Antenna Blockage

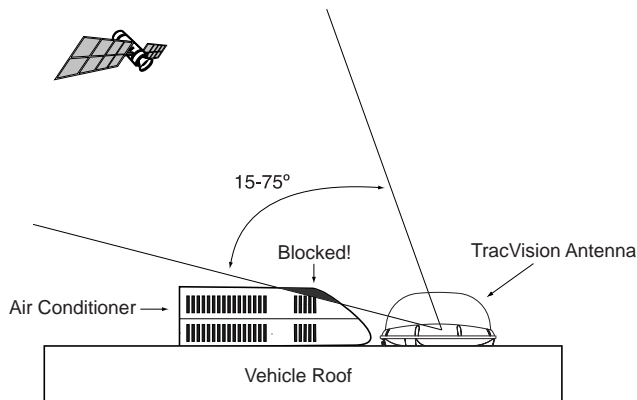

2.1 Choosing the Best Location

- Since the TracVision antenna requires a clear view of the southern sky to receive satellite signals, the ideal antenna site has an unobstructed view of the horizon/satellite all around.
- Keep the antenna clear of any obstructions on the roof (e.g., air conditioners). The antenna requires a 15° to 75° look angle to receive satellite signals.

- Consider the location of the antenna relative to the location of any equipment or necessary wiring within the vehicle.
- For best operation, mount the antenna on a horizontal surface.

2.2 Mounting the Antenna Unit

The following instructions will result in a secure, effective installation and trouble-free operation of your TracVision L3. Table 2-2 lists the materials provided in the TracVision L3 kitpack. Most of these components will be used in the installation process.

Table 2-2
Kitpack Contents

Part	Qty.	KVH Part No.
RF F-Connector	1	23-0170
Tie-wrap	5	22-0013
Flash kit cable and adapter	1	02-1029
Clam Shell Ventilator	1	19-0230
¼"-20 x ⅝" hex screws	4	14-0250-0010
¼" flat washers	4	14-0251

Antenna Mounting Procedure

1. Remove Antenna Unit from shipping container.
2. Remove and save 8 pan head screws and flat washers that hold radome to baseplate. Carefully lift radome straight up until clear of antenna assembly and set aside.
3. Position Antenna Unit in desired location on the centerline of the vehicle with baseplate and mounting plate arrows facing in the same direction (either forward or backward). The proper orientation is illustrated in Figure 2-2.



The liquid-tight connectors on TracVision L3 may face either forward or backward along the centerline of the vehicle for more convenient installation.

Figure 2-2
Proper Orientation of
the Antenna Unit

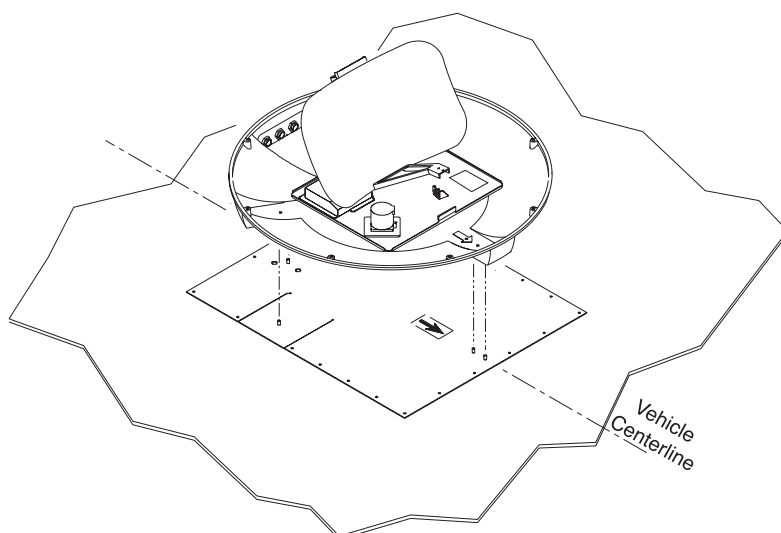

4. While baseplate is in place, mark location(s) on roof for cable access to permit convenient cable access to the liquid-tight fittings on the back of the baseplate.
5. Cut tie-wraps holding antenna unit to the forward shipping restraint.

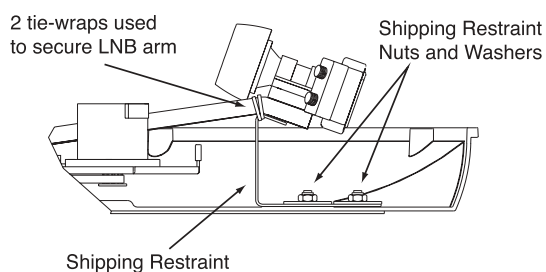

Figure 2-3
Forward Shipping Restraint
(Arranged for Shipping)

- Remove additional nuts and washers connecting baseplate and shipping restraints to the mounting plate. The positions of all three shipping restraints are pictured in Figure 2-4.

Figure 2-4
TracVision L3 Shipping Restraints
(Top View, Installed for Shipping)



Do not discard the shipping restraints, washers, or the nuts. They should be saved for future use in case the antenna unit needs to be removed and shipped to another location. Four ¼" x ⅝" hex head screws have been provided in the kitpack for shipping as the bolts used to hold the shipping restraint during initial shipping are integral parts of the mounting plate.

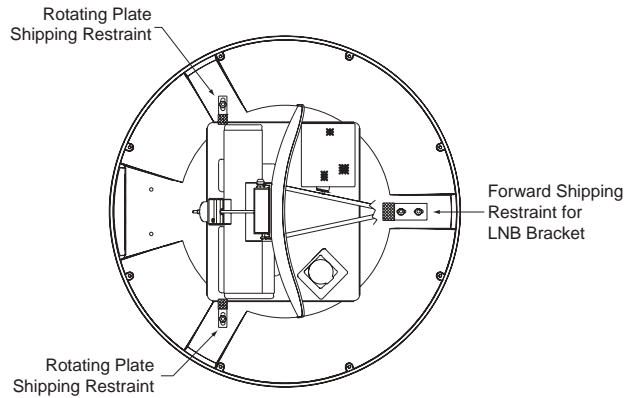

- Remove six ¼"-20 hex nuts and washers that secure the Antenna Unit to the mounting plate.
- Remove Antenna Unit from mounting plate.
- The mounting plate allows the Antenna Unit to be mounted on a curved roof. While the perimeter of the mounting plate is secured to the vehicle with the appropriate fasteners, two flexible wings allow the rear mounting bolts to attach to the antenna baseplate. These may be angled upward to ensure a secure mounting, as shown in Figure 2-5.

Figure 2-5
Mounting the Unit on a
Curved Surface

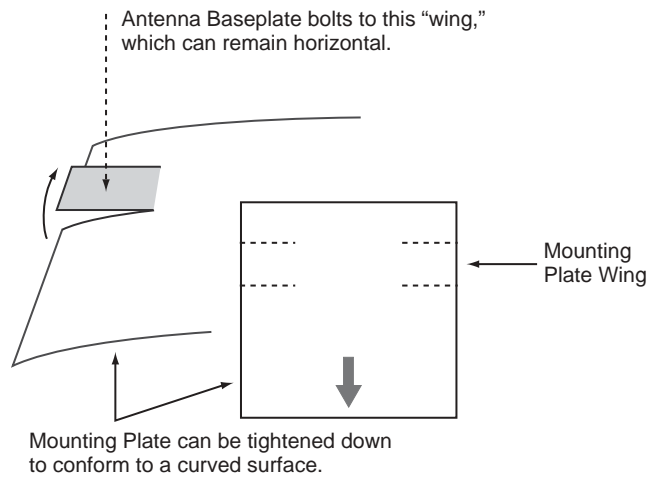

- Using the mounting plate as a template, drill four ⅜" (5 mm)-holes through the roof of the vehicle at each of the four corners. Temporarily secure the mounting plate at the corners with rivets or screws.

11. With the corners secured, use the mounting plate as a template to mark and drill the remaining nineteen $\frac{3}{16}$ " (5 mm)-holes through the roof of the vehicle. Remove plate and clean roof surface. The dimensions of the baseplate and locations of the drill holes are shown in Figure 2-6.

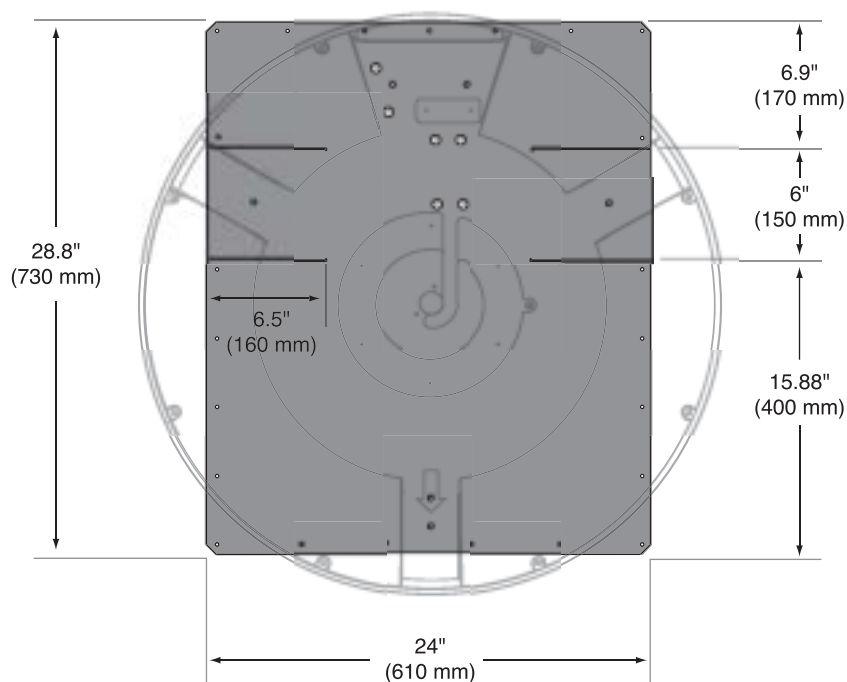
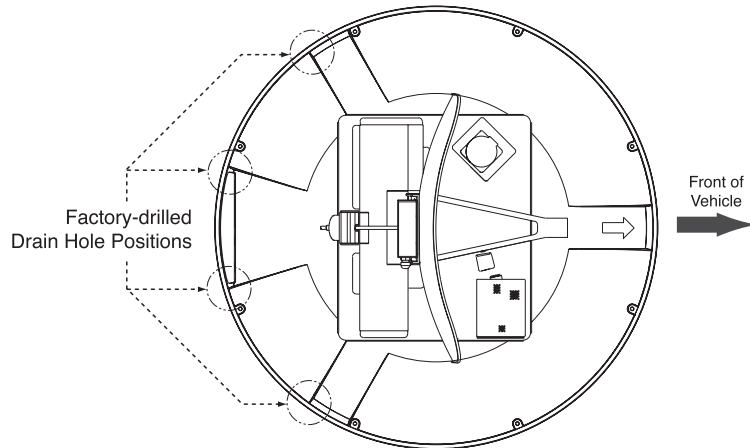

Figure 2-6
Mounting Plate Dimensions

12. Place the construction adhesive over all holes. If using a liquid construction adhesive, apply bead to mounting plate in a zig-zag pattern.
13. Reposition mounting plate over adhesive and attach using $\frac{3}{16}$ " (5 mm)-diameter rivets (or appropriate fasteners). Seal all rivet heads and edges with silicone.
14. Drill cable access hole(s) in vehicle.
15. When unit is installed with connectors facing the rear of the vehicle, the drain holes are located as shown in Figure 2-7 on the following page.

Figure 2-7
Connectors Facing Rear
of Vehicle – Factory-drilled
Drain Hole Locations



15a. (Alternate Drain Holes) If the Antenna Unit is installed with the connectors facing the front of the vehicle, drill out $\frac{3}{16}$ " (5 mm)-drain holes in rear-facing side of baseplate as illustrated in Figure 2-8. The existing factory-drilled drain holes shown in Figure 2-7 must then be plugged with silicone rubber sealant.

Figure 2-8
Connectors Facing Front
of Vehicle – Recommended
Drain Hole Locations



You **MUST** drill out the drain holes as indicated to ensure that any moisture that enters the baseplate is able to drain. Ensure that factory-drilled holes are completely sealed.

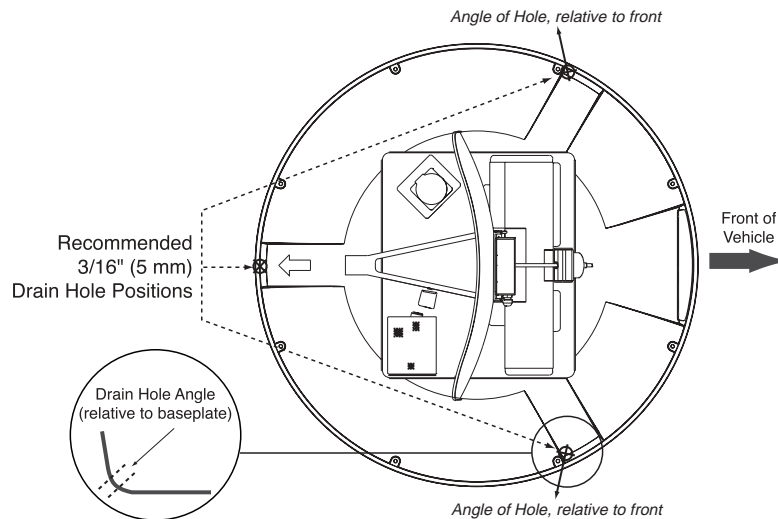

16. Place Antenna Unit on mounting plate and secure using nuts and washers removed in Step 7.
17. For convenient storage, the shipping restraints may be rotated 180° and secured to their original mounting bolts (see Figures 2-9 through 2-11 on the following page).

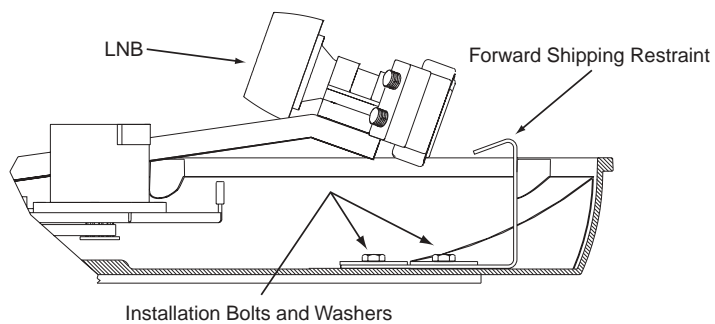

Figure 2-9
Forward Shipping Restraint Storage

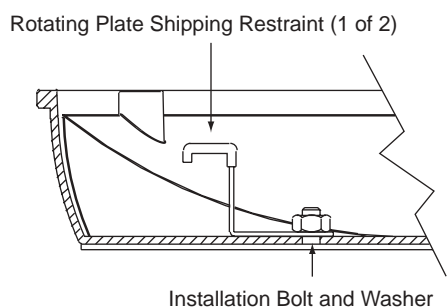

Figure 2-10
Rotating Plate Shipping Restraint Storage

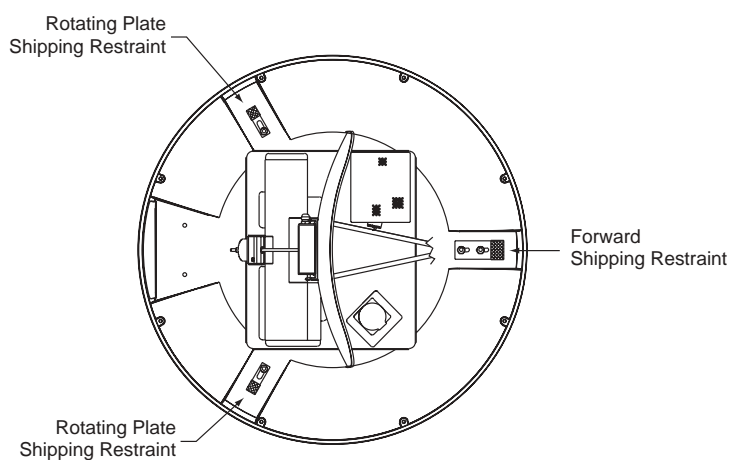

Figure 2-11
TracVision L3 Shipping Restraints
(Storage Position)

17. Proceed to [Section 2.3, "Wiring the TracVision L3 System,"](#) to wire the TracVision L3 system. The radome will be placed back on the baseplate using the hardware removed in Step 2 after wiring and initializing the system.



DO NOT leave an extra length of cable within the baseplate as a service loop. All service loops should be stored within the vehicle's cable access.

Figure 2-12
Proper Wire-to-Terminal Connection

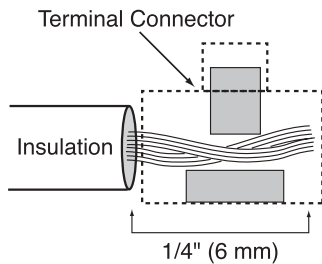

Figure 2-13
Moving the Antenna Reflector

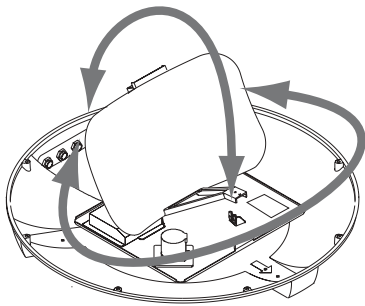
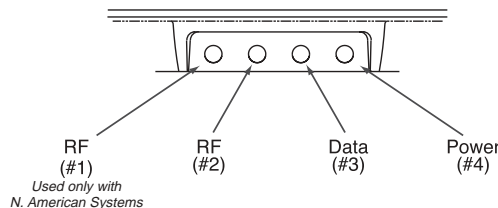

Figure 2-14
Cable Port Assignments
(Exterior of Baseplate)



2.3 Wiring the TracVision L3 System

The following sections provide instructions for properly wiring the Antenna Unit to the IRD and to vehicle power.

Tips for Safe and Successful Wiring within the TracVision L3 Baseplate

- When attaching cables to the TracVision L3 terminal connector strips, make sure the insulation is stripped back approximately 1/4" (6 mm) as illustrated in Figure 2-12. Twist the wires gently to help achieve a good connection. Do not pinch insulation inside the connector.
- After attaching the power and data cables to the appropriate terminal connector strips, tug gently to ensure a firm connection.
- After attaching cables within the TracVision L3 baseplate, eliminate any unnecessary slack in the cables before tightening the liquid-tight fittings.
- Run the RF signal cable into the baseplate last. It will help keep the power and data cables clear of the antenna and LNB.
- After hooking up all of the wiring and removing any slack, slowly rotate the antenna while raising and lowering the reflector to make certain that the cables are all clear of any moving elements as pictured in Figure 2-13.
- Check to be certain that the elevation axis actuator motor shaft (pictured in [Section 5, Maintenance, Figure 5-2](#)) clears all cable connections.
- Completely seal all rooftop cable access holes.

TracVision L3 Cable Ports

On one side of the baseplate are four liquid-tight fittings, which serve the dual purpose of relieving strain on the cables as well as providing a tight seal around the cable access ports.

When wiring is done properly, the sets of cables will overlap each other, as illustrated in Figure 2-15.

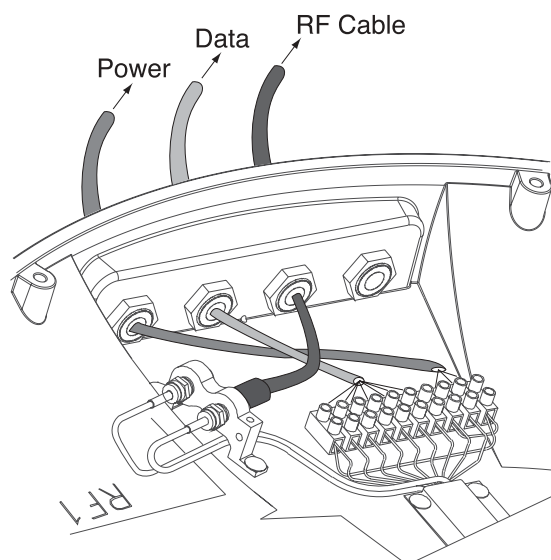

Figure 2-15
Cable Overlap within the
TracVision L3 Baseplate

A switchplate has been provided to serve as the hub of the TracVision L3 wiring (with the exception of the RF cable, which will be connected to the IRD). This switchplate includes an ON/OFF switch and a DB9 maintenance port for easy access to the Antenna Unit's software and diagnostics. Follow these steps to begin the wiring process.

1. Select a location to mount the TracVision L3 switchplate. It should be flat and within reach of the cables connected to the Antenna Unit.
2. Create a panel cutout in the mounting surface. Figure 2-16 illustrates the mounting dimensions and a template has been provided in [Appendix C](#).

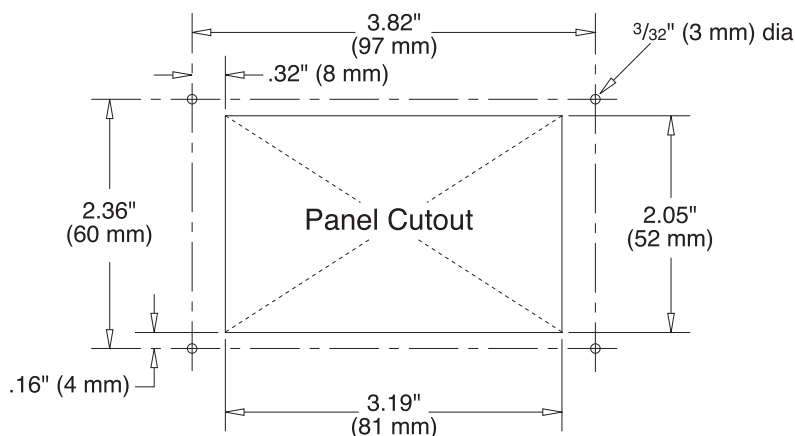

Figure 2-16
Switchplate Panel
Cutout Dimensions



A full-scale panel cutout template has been provided in [Appendix C](#).

3. Run the Antenna power and data cables from the Antenna Unit and out through the panel cutout.
4. Run a cable from vehicle's power (11-16 Vdc) through the panel cutout.

You are now ready to wire the TracVision L3 system to the switchplate connectors and vehicle power.

2.3.1 Wiring the Antenna Data Cable

TracVision L3 will not function properly unless you connect the antenna data cable (Cable #32-0630-30).

Figure 2-17

Proper Terminal Strip Wiring Arrangement – Data Cable

Shield	1	Grnd
Red	2	+12v DC
Black	3	Grnd
Brown/White	4	RTN
Orange/White	5	PC_RXD
White/Brown	6	PC_TXD
White/Orange	7	RTN
White/Gray	8	RF_TXD
Gray/White	9	RF_RXD
Shield	10	Grnd

Antenna Data Cable-to-Baseplate Terminals Wiring Process

1. Feed the cable up to the roof and through the third liquid-tight fitting (#3) from the left as pictured in Figure 2-14.
2. Refer to Figure 2-17 for the proper arrangement of data cable wires within the terminal strip.
3. After connecting the antenna data cable to the TracVision L3, hook up the other end to the switchplate as described in the next subsection.

Antenna Data Cable-to-Switchplate Wiring Process

Find the TracVision L3 antenna data cable (Cable #32-0630-30) where it comes through the panel cutout made earlier. Wire the antenna data cable to the switchplate connectors as indicated in Figure 2-18 on the following page. The connector board is etched with the wire color identification to make the wiring process easier.

Figure 2-18
Antenna Data Cable Wiring
Arrangement

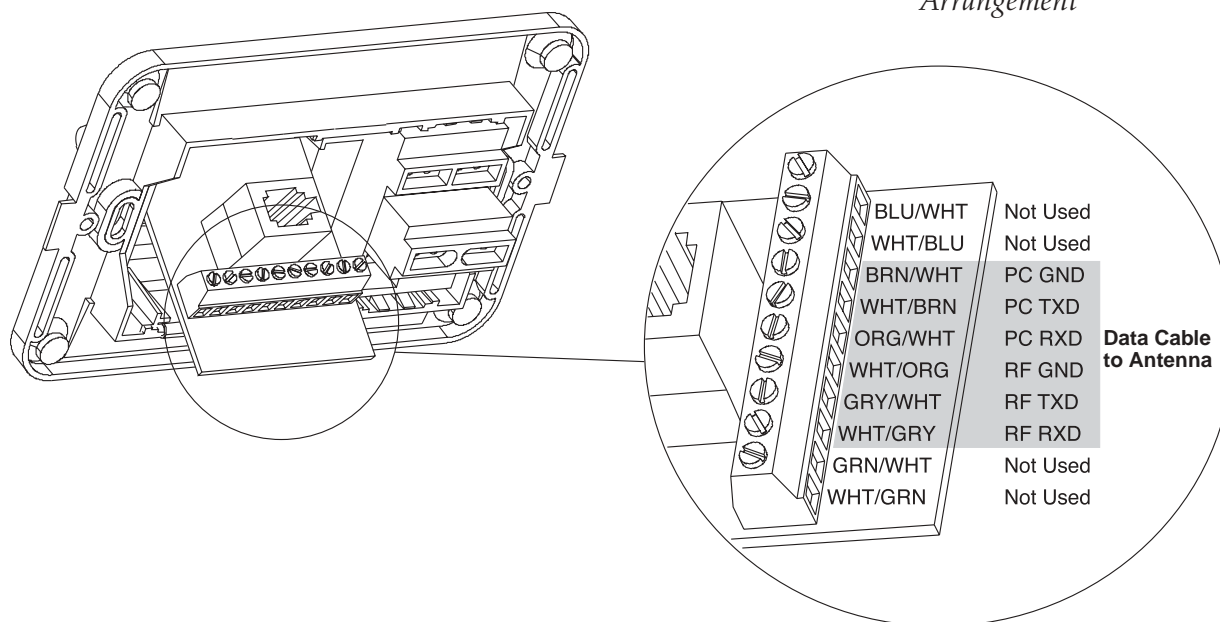

2.3.2 Wiring the Antenna Unit Power Cable

TracVision L3 will not function properly unless you connect the power cable (Cable #32-0590-30).

Power Cable-to-Baseplate Terminals Wiring Process

1. Feed the cable up to the roof and through the fourth liquid-tight fitting (#4) from the left as pictured previously in Figure 2-14.
2. Refer to Figure 2-19 for the proper arrangement of power cable wires within the terminal strip.
3. After connecting the power cable to the TracVision L3, hook up the other end to the switchplate as described in the next subsection.

Figure 2-19
Proper Terminal Strip Wiring
Arrangement – Power Cable

Shield	1	Grnd
Red	2	+12v DC
Black	3	Grnd
Brown/White	4	RTN
Orange/White	5	PC_RXD
White/Brown	6	PC_TXD
White/Orange	7	RTN
White/Gray	8	RF_TXD
Gray/White	9	RF_RXD
Shield	10	Grnd



Before connecting the Antenna Unit to vehicle power, remove the appropriate vehicle fuse to prevent a short circuit. After connecting to vehicle power, replace the fuse.

Power Cable-to-Switchplate Wiring Process

Find the TracVision L3 power cable (Cable #32-0590-30) where it comes through the panel cutout made earlier. Wire the Antenna Unit power cable to the switchplate connectors as indicated in Figure 2-20. After wiring the power cable, connect the power indicator lamp, also as noted in Figure 2-20. After both the power cable and lamp are properly wired, carefully insert the lamp into its socket immediately below the switchplate connectors.

Figure 2-20

Power Cable Wiring Arrangement

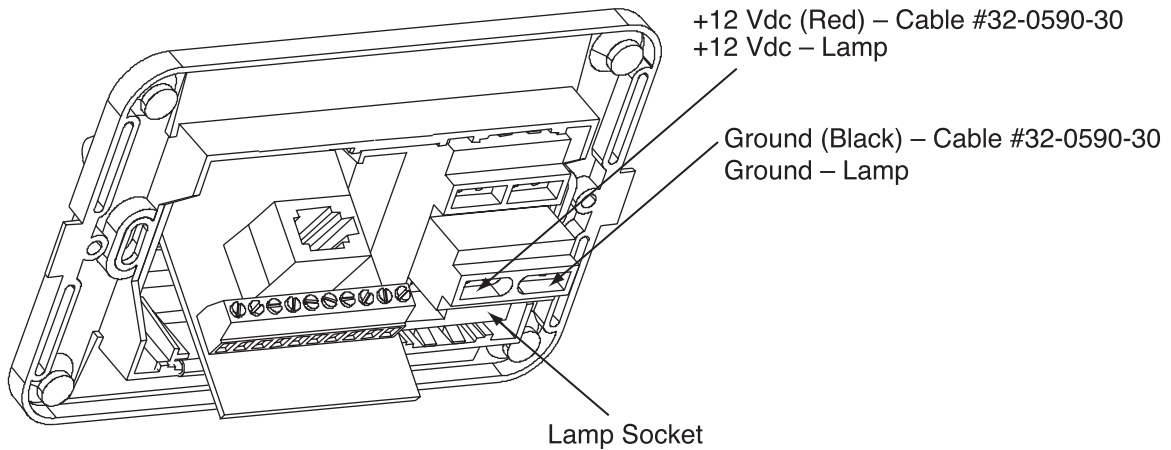

Make sure that all wires are securely fastened within the switchplate connectors.

2.3.3 Connecting to Vehicle Power

After completely wiring the indicator lamp and the data and antenna cables, you must connect the switchplate to vehicle power as pictured in Figure 2-21.

Figure 2-21

Vehicle Power Wiring Arrangement

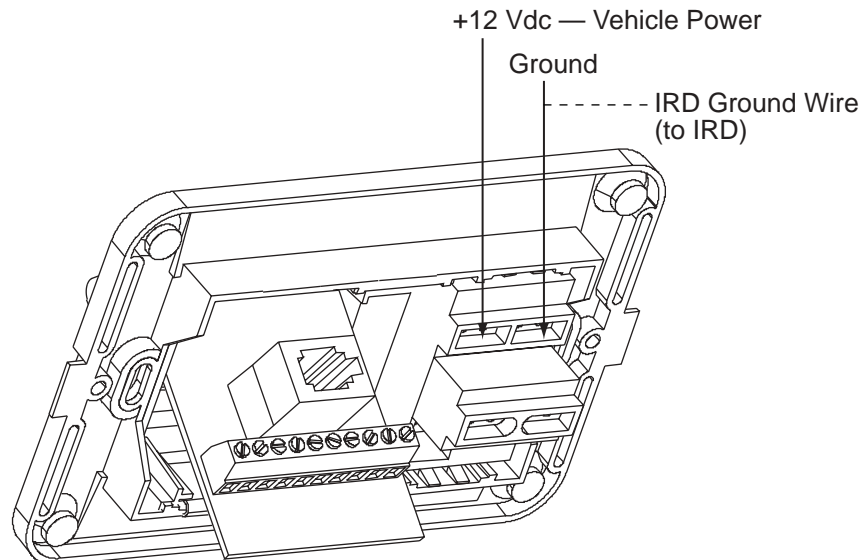

2.3.4 Connecting the IRD Ground Wire

A grounding wire (Cable #32-0583-50) has been provided to connect your IRD to a suitable ground and protect the system. Attach the grounding wire to any suitable screw on the rear panel of the IRD with a good contact with the IRD chassis. The other end should be connected to a suitable ground, ideally the ground connector on the switchplate (see Figure 2-21).

2.3.5 Installing the Switchplate

After completing the switchplate wiring process, you must install the switchplate itself. This process, detailed in the following steps, is illustrated in Figure 2-22.

1. Fit the switchplate assembly and support frame into the panel cutout made in Step 2 in [Section 2.3](#) and flush to the mounting surface.
2. Drill out four $\frac{5}{32}$ " (4 mm) holes in the countersunk settings in the switchplate support frame.
3. Drill four $\frac{3}{32}$ " (2 mm) holes in the mounting surface using the countersunk holes in the support frame as the template. Secure the support frame and switchplate assembly to the mounting surface using the four #6 self-cutting screws.
4. Snap the front cover into place to cover the screws and support frame.



Before securing the switchplate to the mounting surface, be sure to strain relieve the wires connecting to the switchplate connectors. Several tie-wraps have been provided to aid in strain relieving the wires.

Figure 2-22
Mounting the Switchplate Support Frame and Front Cover

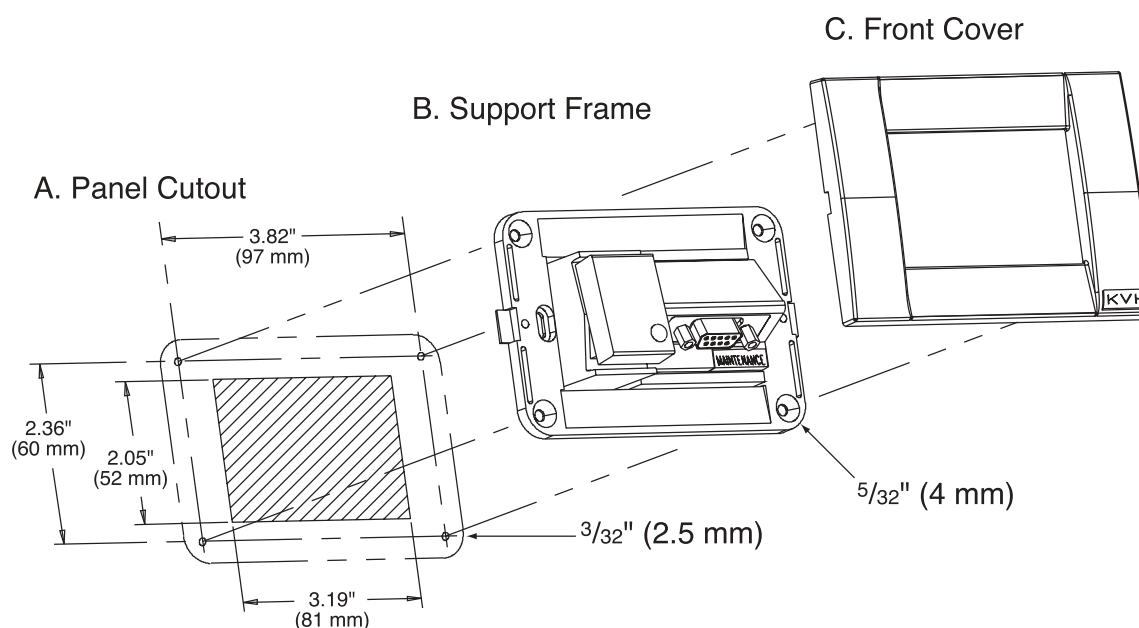

2.3.6 Connecting the Antenna RF Signal Cable to the IRD



When shipped from the factory, the #1 liquid-tight fitting is sealed with a rubber stopper. Leave the stopper in the fitting.

Figure 2-23
Connecting the RF Cable to TracVision L3



KVH has provided an F-connector for use with the TracVision L3. This connector specifically requires the Augat Snap 'n Seal Crimp/Strip Tool, part number IT1000.

If you do not have this tool, you will need to purchase a silicone-filled, weatherproof F-connector (Radio Shack part number 278-236 or equivalent) to use instead.

Figure 2-24a-d
Attaching the KVH-provided F-connector to an RF Cable

The RF signal cable is fitted with an F-type connector at only one end and should be attached to TracVision L3 and the IRD as follows:

1. Feed the bare end of the RF signal cable through the #2 liquid-tight fitting at the back of the TracVision L3 baseplate and away from the dome, leaving the F-connector inside the TracVision L3 baseplate (as pictured in Figure 2-23).

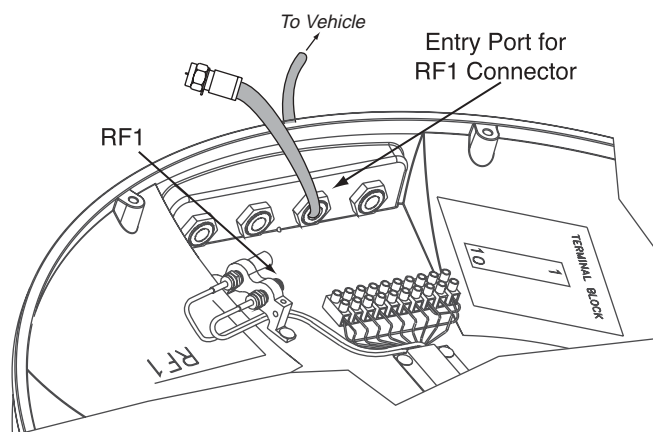

2. Connect the RF signal cable's F-connector to the plug labeled RF1.
3. Feed the bare end of the RF signal cable and pass through the cable hole drilled earlier and into the vehicle.
4. Attach the provided F-connector to the end of the RF signal cable inside the vehicle as illustrated in Figure 2-24a-d, using an Augat Snap 'n Seal Crimp/Strip tool to lock the connector on the cable.
 - A. Slide compression fitting onto raw cable before beginning connector termination.

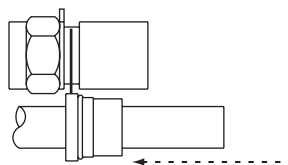

- B. Twist and break off connector body.

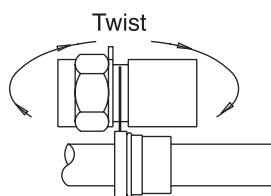

- C. Use the Augat tool to strip the center conductor and trim back the overall jacket. Do not cut through the braid.

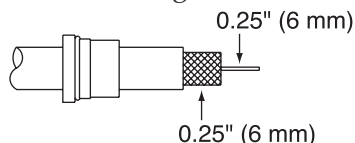

- D. Slide connector body onto the prepared cable. Slide the compression fitting up into the connector body. Use Augat tool to snap on the connector.

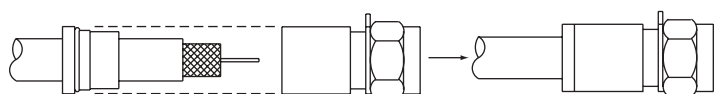

5. Attach the cable to the IRD connector labeled SATELLITE IN.

2.3.6.1 Installing Two IRDs and TVs (North American Systems Only)

To connect a second TV and IRD to the TracVision L3 system, you must connect a second RF cable to the RF2 connector within the Antenna Unit baseplate. The other end of the RF cable should be run down into the vehicle and connected directly to the second IRD. Each IRD/TV pair can operate independently of the other, allowing different viewers to watch different channels.

2.3.6.2 Connecting Three or More IRDs and TVs (North American Systems Only)

To install three or more IRD/TV pairs, an active multiswitch (Channel Master model 6214IFD or equivalent) is placed between the Antenna Unit and the IRDs. Figure 2-25 on the following page illustrates typical wiring arrangements for multiple IRDs. If more than four IRDs are required, contact KVH for additional wiring instructions. Mount the multiswitch unit in accordance with the manufacturer's instruction sheet.



KVH recommends the use of RG-6 or RG-11 (75 ohms) cable for RF wiring. Use of non-RG-6 or RG-11 (75 ohms) cables will result in degraded performance. The KVH warranty does not cover degraded performance due to improper wiring.

Figure 2-25

*Installing Three or More IRDs
Using an Active Multiswitch
(North American Systems Only)*



TracVision L3 has the capability to switch from one satellite to another when you choose TV channels that are carried by your two selected satellites. However, the use of an active multiswitch may interfere with the 22 KHz tone sent by DIRECTV+ IRDs to the antenna. As a result, the antenna may not receive the signal to change satellites when you change channels using your DIRECTV+ remote.

In this case, you will need to use the manual satellite switch procedure explained in Section 3.2, “Changing Channels and Switching to the Second Satellite.”

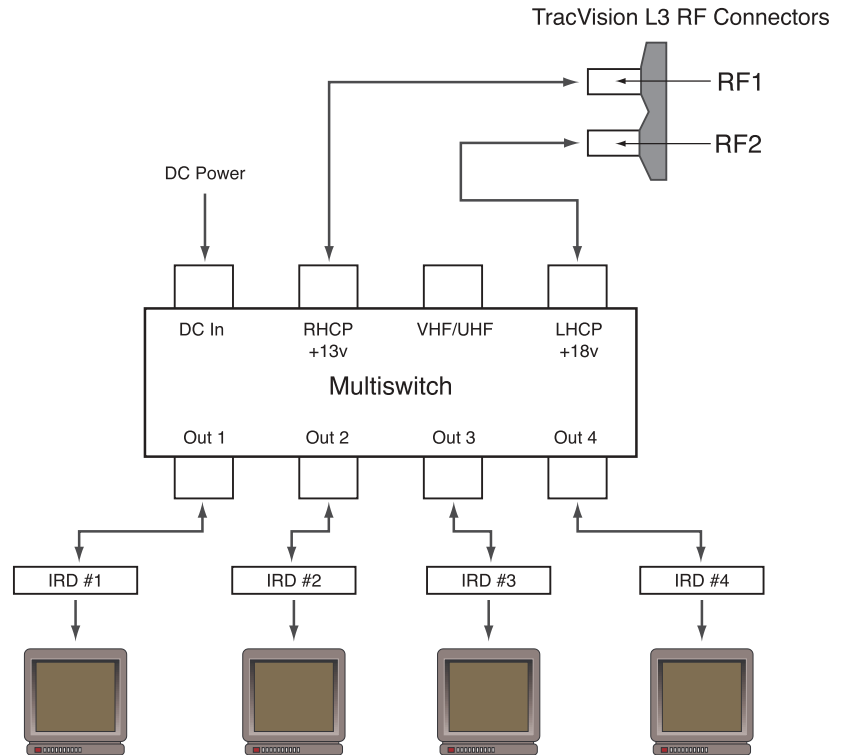

1. Connect the RF cable tagged “RF1” to the multiswitch input labeled “LNB RHCP +13V”.
2. Connect a second RF cable to the multiswitch input labeled “LNB LHCP +18V”.
3. Connect the multiswitch outputs to individual IRD inputs. Use RG-6 cable terminated with F-type connectors for all RF connections.
4. Terminate all unused output connectors with 75 ohm DC blocks (Channel Master #7184, Radio Shack #15-1259 or equivalent).

Commissioning the IRD

Please refer to the user manual that accompanied your IRD for instructions on properly commissioning the system.

2.4 Selecting the Active Satellite

As noted previously, TracVision L3 can track a variety of DVB-compatible and DSS satellites. The system contains a preprogrammed library of European and North American satellites. It also has two open slots that you may use to program two additional satellites of your choice. Tables 2-3 and 2-4 provide a grid of possible satellite pairs. Two of these satellites may be selected to reside in the system's active memory as Satellites A and B. Once this is done, changing the channel on the IRD remote control will tell the antenna to track one or the other, making it easy to switch between the satellites of your choice.

Table 2-3

Available European Satellite Pairs (European LNB Required)

	Astra 1	Astra 2N	Astra 2S	Hispasat	Hotbird	Sirius	Thor
Astra 1		✓	✓		✓	✓	
Astra 2N	✓				✓		
Astra 2S	✓				✓		
Hispasat							
Hotbird	✓	✓	✓			✓	
Sirius	✓				✓		✓
Thor						✓	

Table 2-4

Available N. American Satellite Pairs (U.S.-style LNB Required)

	DSS_101	DSS_110	DSS_119	Echo_61	Echo_110	Echo_119	Echo_148	Expressvu
DSS_101			✓					
DSS_110*								
DSS_119	✓							
Echo_61					✓	✓		✓
Echo_110				✓		✓	✓	✓
Echo_119				✓	✓		✓	✓
Echo_148					✓	✓		✓
Expressvu				✓	✓	✓	✓	

* Contact KVH or DIRECTV for complete details on tracking and receiving signals from DSS_110.

The satellites listed in TracVision L3's preprogrammed satellite library will be sufficient for most users. However, if you wish to install one or two user-defined satellites, proceed to [Section 2.4.2, "Programming User-defined Satellites."](#) After configuring the user-defined satellites, return to the satellite installation process in [Section 2.4.1, "Installing Your Selected Satellites."](#)

2.4.1 Installing Your Selected Satellites

When you first connect to the system, it is programmed with the factory default satellite assignments:

- Europe: Astra 1 (Sat. A) and Hotbird (Sat. B)
- N. America (US DIRECTV): DSS_101 (Sat. A) and DSS_119 (Sat. B)
- N. America (US DISH Network): Echo_119 (Sat A) and None (Sat B)



The satellite configuration on your IRD must match the satellite setting on the TracVision L3 system.

Satellite A on the TracVision L3 must be the same satellite as IRD Alternative 1 (or A, based on your IRD) and must be assigned the IRD DiSEqC 1 setting.

Satellite B on the TracVision L3 must be the same satellite as IRD Alternative 2 (or B, based on your IRD) and must be assigned the IRD DiSEqC 2 setting.

Refer to your IRD user manual for complete instructions for your IRD.

Should you wish to track a different satellite (either from the satellite library or a user-defined satellite), you must instruct the antenna which satellites will be in the active satellite pair.

Connecting to the TracVision L3 Maintenance Port

To do so, it is necessary to connect a PC to the terminal maintenance port on the switchplate. The diagnostics procedure requires terminal emulation software such as PROCOMM, Windows Terminal, or Windows 95/98 Hyperterminal. Use the settings appropriate to your application.

1. Connect one end of the PC data cable to the DB9 connector on the switchplate. Connect the other end to the serial port on the PC (a 9-pin/25-pin connector adapter may be needed for some PCs).
2. Open the terminal emulation software and establish the following settings:
 - 9600 baud
 - no parity
 - 8 data bits
 - 1 start bit
 - 1 stop bit
 - no flow control

3. Apply power to the TracVision L3 system and allow the system to complete full initialization. Data should be scrolling on the PC display to identify any system problems detected. If no data is seen, recheck your connections and the terminal software setup.

Installing the Satellite of Choice

Once the data connection has been made between the PC and the TracVision L3, you must assign the satellites you wish to have in the satellite pair. On the maintenance screen, put the antenna in Idle Mode by typing **HALT**, then enter the SATINSTALL command:

Command:	SATINSTALL,<sat_a_name>,<sat_b_name><cr>
Where:	<p><sat_a_name> = the name of your choice for Satellite A</p> <p><sat_b_name> = the name of your choice for Satellite B</p>

Table 2-5 lists the assigned names for satellites that are in the preprogrammed European satellite library. If you do not wish to assign a pair of satellites, enter **None** as the name of Satellite B.

After you have assigned satellites as Satellites A and B, the final step is to tell the antenna which of the two satellites it should acquire and track. This step should be carried out the first time a satellite is selected, allowing the system to carry out the initial download of the channel guide. To do so, enter the Satellite Selection parser command as follows:

Command:	@L,x<cr>
Where:	x = A or B (one of your selected satellites as defined during the SATINSTALL process)

Choosing A or B will assign the antenna to acquire and track that installed satellite. To complete the process, type **ZAP<cr>** to restart the system. Be sure the IRD satellite configuration matches your chosen TracVision L3 settings.

Table 2-5

Satellite Installation Names

Satellite	Install Name
European Satellites	
ASTRA1 19.2°E	ASTRA1
ASTRA2N 28.2°E	ASTRA2N
ASTRA2S 28.2°E	ASTRA2S
Hispasat 30.0°W	HISPASAT
Hotbird 13.0°E	HOTBIRD
Sirius 5.0°E	SIRIUS
Thor 0.8°W	THOR
North American Satellites	
DSS 101° W	DSS_101
DSS 110° W	DSS_110
DSS 119° W	DSS_119
EchoStar 61° W	Echo_61
EchoStar 110° W	Echo_110
EchoStar 119° W	Echo_119
EchoStar 148° W	Echo_148
ExpressVu	Expressvu
Other Installation Designations	
User-defined 1	USER1*
User-defined 2	USER2*
None	None

* *USER1 and USER2 will only be available if one or two user-defined satellites have been added to the library as detailed in Section 2.4.2, "Programming User-defined Satellites."*

2.4.2 Programming User-defined Satellites

The TracVision L3 satellite library has two open slots that you may use to program two user-defined satellites in case you want to install/watch a satellite that is not in the KVH predefined list. To configure a user satellite, the system must first be in Idle Mode (by typing **HALT**) and then information about the satellite must be provided, including:

- Satellite name
- Satellite position (longitude)
- Transponder information for each of the following polarizations/frequencies:
 - vertical high & vertical low
 - horizontal high & horizontal low
- Transponder information includes:
 - frequency
 - symbol rate
 - FEC code, and
 - network ID (in hexadecimal format)
- Decoder type

This information can be obtained from your satellite service provider or from sites on the Internet, such as www.satcodx.com. For your reference, the satellite configuration information for the predefined satellites has been provided in [Appendix D](#).

Entering User-defined Satellite Data

Once the link between the PC and the TracVision L3 is established as described in [Section 2.4, "Selecting the Active Satellite,"](#) it is necessary to provide initial longitude data regarding the user-defined satellite. To do so, enter the SATCONFIG parser command via PC as follows:

Command:	SATCONFIG,USERX,YYY,Z,D,L<cr>
Where:	<p>X = 1 or 2 (satellite alternative)</p> <p>YYY = longitude (0-180)</p> <p>Z = E (East) or W (West)</p> <p>D = decoding type (0=test, 1=DSS-A, 2=DSS-B, 3=DVB)</p> <p>L = LNB polarization (C=circular, L=linear)</p>
Function:	configures one of the user-configurable satellites with the longitude provided
Response:	<p>if valid entry, echoes the input data</p> <p>if invalid entry, returns error message</p>

After entering the SATCONFIG command, you must turn on the DEBUG mode by typing **@DEBUGON**. Following the entry of the SATCONFIG and DEBUGON commands, enter the satellite transponder information via PC as follows:

Command:	@SATCONFIG,X,N,F,S,C,ID,P,B,D<cr>
Where:	<p>@SATCONFIG = directs data to the RF Board</p> <p>X = satellite location A or B</p> <p>N = satellite table # (98 & 99 are slots for user-configured satellites)</p> <p>F = frequency in MHz (either 00000 or a range from 10700 - 12700)</p> <p>S = the satellite transponder symbol rate in Mbit/second (01000 - 29999)</p> <p>C = the FEC code (e.g., 12, 23, 34, 56, 67, 78)</p> <p>ID = the satellite network ID in hexadecimal format (0x####)</p> <p>P = the LNB polarization (v=vertical, h=horizontal)</p> <p>B = the LNB down conversion frequency (l=low, h=high, u=USA)</p> <p>D = decoding type (0=test, 1=DSS-A, 2=DSS-B, 3=DVB)</p>

This information has to be entered for each of the four transponder categories:

- vertical high
- vertical low
- horizontal high
- horizontal low

TracVision L3 requires that the data fields for all four transponder categories be provided. If the selected satellite does not have information for one or more of the transponder categories, default information should be entered in the fields as follows:

Table 2-6
Default Transponder Values

Transponder Data	Default Value
Frequency	00000
Symbol Rate	27500
FEC Code	the same value as provided for those transponders with data
Network ID	0x0000
Polarity and Band	whichever combinations are not already provided

After entering this information, it is necessary to save these settings. To do so, type:

@SAVE,A (or **@SAVE,B** if this data is for Satellite 2)

@DEBUGOFF

After completing this process, restart the system by either cycling power or typing **ZAP** in the maintenance screen.

One of your user-defined satellite options has now been added to the TracVision L3 satellite library. This option will now be available the next time the SATINSTALL command is given.

An Example of Configuring a User-defined Satellite

The following is an example of configuring the fictional YOURSAT 101 as the USER1 configured satellite. Prior to configuring this satellite or any others, be certain to get the most up-to-date information from one of the sources previously discussed.

Yoursat 101 at 7 West, DVB decoder, Linear Polarization LNB

<i>Horizontal High</i>	
Frequency	11.966 GHz
Symbol Rate	27500
FEC Code	3/4
Network ID	2048 (dec) = 0x0800
<i>Vertical High</i>	
Frequency	11.823 GHz
Symbol Rate	27500
FEC Code	3/4
Network ID	2048(dec) = 0x0800
<i>Vertical Low</i>	
No Data Listed	
<i>Horizontal Low</i>	
No Data Listed	

Table 2-7

*Sample User-defined
Satellite Configuration*

Based on this information, the data entered via the PC would look like this, assuming that YOURSAT 101 would be Satellite A:

```
SATCONFIG,USER1,7,W,3,L
@DEBUGON
@SATCONFIG,A,98,11966,27500,34,0x0800,H,H,3
@SATCONFIG,A,98,11823,27500,34,0x0800,V,H,3
@SATCONFIG,A,98,00000,27500,34,0x0000,V,L,3
@SATCONFIG,A,98,00000,27500,34,0x0000,H,L,3
@SAVE,A
@DEBUGOFF
ZAP
```

2.5 Setting the Skew Angle (European Systems Only)

The Antenna LNB skew angle must be adjusted to optimize channel reception. Refer to your satellite service provider for the proper skew angle for the selected satellite service and geographical location. The skew angle for KVH predefined satellites can also be obtained by using a PC connected to the maintenance port. Enter your latitude and longitude using the GPS command (refer to [Appendix F.6](#) for details) and then type **SKEWANGLE**. The system will respond with the skew angle for whichever satellite is currently selected.

Figure 2-26
Skew Adjustment (European
Systems Only)

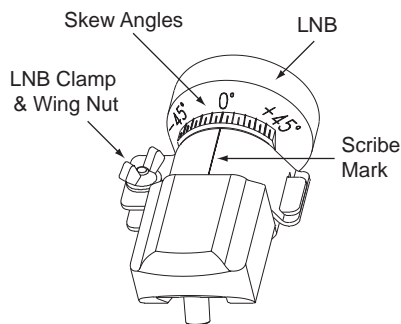

Adjusting the LNB Skew Angle

1. Determine the skew angle for the selected satellite and region.
2. Loosen the wing nut on the LNB clamp so that the LNB can be moved.
3. Carefully rotate the LNB so that the scribe mark on the LNB clamp is aligned with the proper angle measurement.
4. Tighten the wing nut and LNB clamp to secure the LNB.

2.6 Checking Out the System

To complete the TracVision L3 installation, it will be necessary to verify that the system functions properly. Critical to ensuring that the system is configured and operating properly is to check the system startup routine to ensure that the system is operating within normal parameters.

To do so, it is necessary to connect a PC to the terminal maintenance port. The diagnostics procedure requires terminal emulation software such as PROCOMM, Windows Terminal, or Windows 95/98 Hyperterminal. Use the settings appropriate to your application.

1. Connect one end of the PC data cable to the DB9 connector on the switchplate. Connect the other end to the serial port on the PC (a 9-pin/25-pin connector adapter may be needed for some PCs).

2. Open the terminal emulation software and establish the following settings:
 - 9600 baud
 - no parity
 - 8 data bits
 - 1 start bit
 - 1 stop bit
 - no flow control
3. Apply power to the TracVision L3 system and allow the system to complete full initialization. Data should be scrolling on the PC display to identify any system problems detected. If no data is seen, recheck your connections and the terminal software setup.
4. After completing the review of the startup and operational routines, shut down the system.

Additional European System Checks

1. If the system is working properly based on the startup information, refer to your regional satellite programming guide. Select several channels from your first active satellite service to confirm that the system is receiving and decoding the signals properly. If possible, view both horizontally and vertically polarized channels.
2. Select several channels from your second active satellite service to confirm that the system is receiving and decoding the signals properly. If possible, view both horizontally and vertically polarized channels.

Completing the Installation

Once the system has been installed and is operating properly, replace the radome.



*If a need does arise to paint the radome, **ONLY use non-metallic automotive paint** to avoid degrading the RF signal strength and the reception quality.*

2.7 Configuring TracVision L3 for Remote Satellite Dish Operation

In some campground locations, dense foliage will block the satellite signal. In these situations, a remote portable antenna may be the only solution to satellite signal reception.

The wiring option for the remote dish is very simple and should be installed when the TracVision L3 is installed. A high-quality “A/B switch” should be used to change from TracVision L3 dish reception to remote antenna operation. The recommended wiring arrangement for remote dish operation is illustrated in Figure 2-27.

Figure 2-27
Remote Dish Wiring Configuration

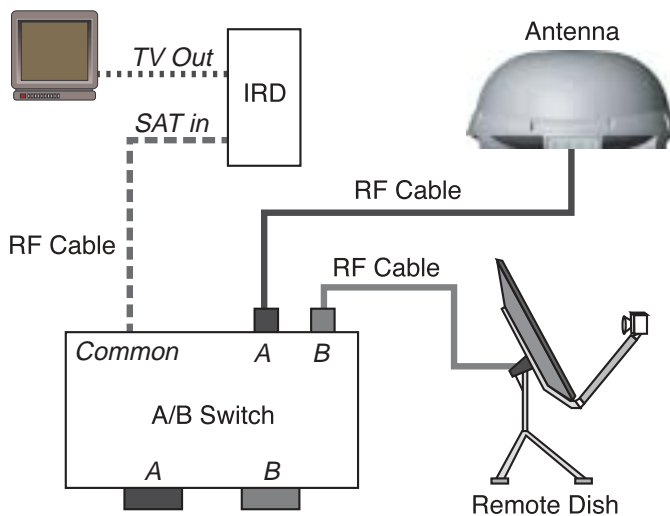

2.8 Changing Geographic Location

If you move from Europe to the U.S., or from the U.S. to Europe, you will need to modify your TracVision L3 system to receive satellite TV signals in the new geographic area.

To begin receiving satellite signals in the new area, perform the following steps.

Swap LNBS

To receive the proper satellite signals in the new geographic location, your TracVision antenna must be equipped with the appropriate LNB for that location. If moving from Europe to the U.S., you will need to install a North American-style LNB. If moving from the U.S. to Europe, you will need to install a European-style LNB. Table 2-8 lists the part numbers for ordering these LNB options.

Part Name	Part Number
European-style LNB	19-0196
North American-style LNB	19-0056

Table 2-8
LNB Part Numbers

With the new part, you will receive an easy-to-understand instruction sheet for swapping the LNBS.

Install New Satellites

When you move to a new area, the list of available satellites changes. If you're moving to Europe, you will need to choose a new satellite pair from the list of available European satellites (see Table 2-3). If you're moving to the U.S., you will need to choose a new satellite pair from the list of available North American satellites (see Table 2-4). For details on installing these new satellites, refer to [Section 2.4.1, "Installing Your Selected Satellites."](#)

Replace the IRD

In order to receive satellite TV service in your new geographic location, you will need to purchase an IRD designed for that location. Refer to your satellite TV service provider for more information.

3 Using Your TracVision L3

For TracVision L3 to receive the satellite signals, the antenna must have a clear line of sight to the satellite. If you only receive intermittent signals or the antenna cannot find the satellite, check around your vehicle for any objects that could be blocking the signal, such as trees, buildings, highway overpasses, etc.



Figure 3-1

Be Aware of Objects that Might Block the Satellite Signals

You must also be located within the selected satellite's coverage area in order to receive its signal. Refer to your satellite television service manual to check the viable coverage area. *For your convenience, KVH provides links to several web sites that offer satellite coverage information. Simply go to our web site at: www.kvh.com/footprint/index.html.*

3.1 Turning on the System

The TracVision L3 system is easy to use. Antenna unit initialization and satellite acquisition is completely automatic.

To use the TracVision L3 system:

1. Turn on the IRD and the television. (Refer to your IRD user manual for complete operating instructions for the IRD.)
2. Turn on the antenna using the switchplate, as pictured in Figure 3-2.



To minimize the time it takes the antenna to acquire the satellite, do not change the channel during the startup process or cable unwrap.

Figure 3-2

Turning on the TracVision L3 Using the Switchplate

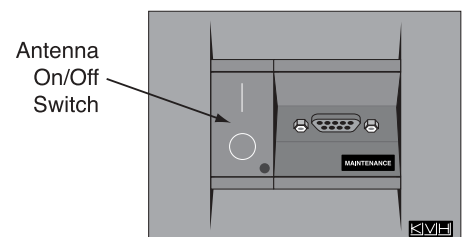

3. Avoid turning for 60 seconds after turning on the antenna to allow the antenna gyro to initialize properly.

3.2 Changing Channels and Switching to the Second Satellite



The satellite configuration on your IRD must match the satellite setting on the TracVision L3 system.

Satellite A on the TracVision L3 must be the same satellite as IRD Alternative 1 (or A, based on your IRD) and must be assigned the IRD DiSEqC 1 setting.

Satellite B on the TracVision L3 must be the same satellite as IRD Alternative 2 (or B, based on your IRD) and must be assigned the IRD DiSEqC 2 setting.

Refer to your IRD user manual for complete instructions for your IRD.

** DiSEqC applies to European systems only*

TracVision L3 can have a pair of satellites installed, either one of which can be the active satellite selection. There are several methods to select whether your TracVision L3 will track Satellite A or B.

IRD Remote Control

If you have followed the installation instructions, your system should be set to the active satellite pair of your choice and the system should have downloaded the appropriate channel guides. You must also have a properly configured IRD (if this has not been done, refer to your IRD User's Manual for instructions for your specific IRD). When the TracVision L3 system and the IRD have matching configurations, switching from one satellite to the other is as easy as changing the channel using the remote control. TracVision L3 will automatically switch from Satellite A to B and back again as necessary to receive your selected channel.

Maintenance Port Switch

As described in [Section 2.4, "Selecting the Active Satellite,"](#) the maintenance port can also be used to tell the Antenna Unit which satellite it should acquire and track. To make the antenna track either Satellite A or B, first connect the PC to the maintenance port as described in Section 2.4. Once the data connection is made, enter the Satellite Selection parser command as follows:

Command: **@L,x<cr>**

Where:	x = A or B (one of your selected satellites as defined during the SATINSTALL process)
--------	---

Choosing A or B will assign the antenna to acquire and track that installed satellite.

DIRECTV Satellite Subscribers

DIRECTV subscribers in certain regions of the United States will require a DSS Plus™ IRD to receive both satellite and local channels. Check with [DIRECTV](#) for regional requirements. The DSS Plus IRD allows you to switch channels using the remote control. If you are a DIRECTV subscriber, but do not have a DSS Plus IRD, use the maintenance port switching option previously described.

EchoStar and ExpressVu Satellite Subscribers

[EchoStar](#) and [ExpressVu](#) subscribers will need to use the maintenance port switching method.

Internet Access

Your TracVision antenna has the capability of receiving satellite Internet signals. However, while some Internet services have been established in parts of Europe and Canada, satellite Internet access is still not widely available. If one of these providers offers Internet coverage in your particular area, contact that service directly for more information.

3.3 Watching TV on the Move and at Rest

TracVision L3 is designed to operate as efficiently and as reliably as possible both when your vehicle is in motion and parked.

Using Your TracVision L3 When Parked

When your vehicle is stopped, it is not necessary for the TracVision L3 to be turned on. After parking your vehicle and confirming that the antenna is receiving the satellite signal, you may turn off the TracVision L3 unit to avoid unnecessary use of power. Because the LNB receives its power from the IRD, the antenna will continue to receive the satellite TV signals and relay them to the IRD.

However, if you plan to change to a channel that is broadcast by another satellite, TracVision L3 must be turned on so the antenna can search for, identify, and lock onto the different satellite.

Cable Unwrap

The Antenna Unit can rotate a full 720° before coming to the end of its cable. If it does so, the system automatically unwraps the cable by quickly rotating the dish in the opposite direction. During this process, your television transmission will be frozen momentarily while the cable unwraps and the antenna reacquires the satellite.



Unlike turning the power off, the antenna will still be operational and drawing power when in Sleep Mode. If you are going to be parked for an extended period of time, turning off the antenna will conserve power while still allowing you to receive the TV signals.

Sleep Mode

When the vehicle has come to a stop and the antenna holds its position for 1 minute, the Antenna Unit enters Sleep Mode, which turns off the conical scan tracking, reducing any motor noise the antenna may be making. As soon as the vehicle moves, Sleep Mode will automatically be turned off and the system will begin tracking the satellite again. This convenient feature is ideal for when a vehicle is parked for a short time or idling and passengers want to watch TV.

KVH recognizes that some customers may not want to take advantage of this convenient feature. In this case, it is possible to disable Sleep Mode using a simple software command as follows:

1. Connect a laptop computer to the system used the maintenance port and a terminal emulation program, as described in [Section 2.4.1, Installing Your Selected Satellites](#).
2. Turn on the antenna. When the limit switch test is complete:
 - A. Type **HALT<cr>** (<cr> indicates a carriage return/ENTER key)
 - B. Type **DEBUGON<cr>**
 - C. Type **SLEEPOFF<cr>**
3. Cycle the antenna's power. Sleep Mode is now disabled.
4. To reactivate Sleep Mode, follow this same process, instead using **SLEEPON<cr>** in Step C.

Conical Scan Tracking

The antenna control unit uses conical scanning to maintain peak signal strength to the receiver and to update the satellite's position. When conical scan tracking is active, the antenna moves continually with a circular motion to sweep across the satellite's peak signal. The signal strength is then fed back to the control circuits to keep coming back to the direction of the strongest signal.

If the satellite signal is lost while the system is in conical scan track mode, the control software imposes a 45-second time-out delay. If the signal is not regained during that time, the antenna reverts to the set of Search Modes to start looking for the satellite signal. This is an automatic process that does not require user intervention.

4 Troubleshooting

The troubleshooting matrix shown in Table 4-1 identifies some trouble symptoms, their possible causes, and references to troubleshooting solutions.

Table 4-1
Troubleshooting Matrix

SYMPTOM	POSSIBLE CAUSE (AND SOLUTION)												
	Blown fuse or improper wiring (Section 4.1.1)	Incorrect satellite configuration (Section 4.1.2)	Dew or rain pooling on dome (Section 4.1.3)	Outside satellite coverage zone (Section 4.1.4)	Vehicle turning during startup (Section 4.1.5)	Passive or loose RF connectors (Section 4.1.6)	IRD wiring (Section 4.1.7)	IRD faulty (Section 4.1.8)	Antenna gyro faulty (Section 4.2.1)	Antenna LNB assembly faulty (Section 4.2.2)	LNB assembly faulty (Section 4.3)	LNB faulty (Section 4.3)	
Antenna non-functional	X												
Antenna not switching channels/satellites		X											
No picture on TV set				X	X	X	X	X	X	X	X	X	X
Intermittent picture for short intervals			X	X	X	X	X	X	X	X	X	X	X
System works at rest but not on the move			X								X		
System will not find satellite			X	X	X	X	X		X			X	
Snowy television picture									X				
Picture jumbled, parts missing, freezing				X									

4.1 Causes and Remedies for Common Operational Issues

There are a number of common issues that can affect the signal reception quality or the operation of the TracVision L3. The following sections address these issues and potential solutions.

4.1.1 Blown Fuse or Improper Wiring

If the Antenna Unit is installed but entirely non-responsive, there are three key factors to check as part of the troubleshooting process:

1. Blown Fuse – The Antenna Unit is equipped with a fuse mounted on its CPU Board. If this fuse has blown or been broken, the Antenna Unit will not operate. Refer to [Section 5.4.1, “PCB Removal and Replacement,”](#) for details on the fuse location and how to access the CPU Board.
2. Wiring – If the system has been improperly wired, the Antenna Unit will not operate correctly. Refer to [Section 2.3, “Wiring the TracVision L3 System,”](#) for complete system wiring information.

4.1.2 Incorrect Satellite Configuration

The satellite configuration on your IRD must match the satellite setting on the TracVision L3 system.

- Satellite A on the TracVision L3 must be the same satellite as IRD Alternative 1 (or A, based on your IRD) and must be assigned the IRD DiSEqC 1 setting.*
- Satellite B on the TracVision L3 must be the same satellite as IRD Alternative 2 (or B, based on your IRD) and must be assigned the IRD DiSEqC 2 setting.*

* *The DiSEqC settings only apply to European systems.*

Refer to your IRD user manual for complete instructions on configuring your IRD.

4.1.3 Satellite Signal Blocked

Satellite signals can be blocked or degraded by trees and branches, buildings, mountains, overpasses, or equipment on the vehicle itself. Refer to [Section 2.1, “Choosing the Best Location,”](#) to make certain that the TracVision L3 unit is in the optimal location. Simply moving the vehicle to clear an external obstruction will also restore signal quality.

4.1.4 Dew or Rain Pooling on Dome

Dew or rain can occasionally pool on the top of the radome. While this moisture will usually be dispersed when the vehicle is in motion, it can disrupt the signal while the vehicle is at rest. This issue can be minimized with two approaches:

1. Spray the dome with hosed water to remove the dew from the dome surface.
2. Periodically apply liquid dish detergent to the dome surface. Wipe the full-strength detergent on the dome and allow it to dry. This treatment will provide a film that will help moisture bead up and roll off the dome.

4.1.5 Outside Satellite Coverage Zone

TracVision L3 will provide outstanding reception throughout the entire coverage area for your satellite television service of choice. However, signal quality can be degraded as you approach the fringe coverage areas. Refer to your satellite television service manual to check the viable coverage area.



For your convenience, KVH provides links to several web sites that offer satellite coverage information. Simply go to our web site at www.kvh.com/footprint/index.html.

4.1.6 Vehicle Turning During Startup

If the vehicle turns during the 60-second startup and initialization sequence that occurs immediately after turning on the power to the TracVision L3 unit, the antenna gyro will record that variable motion as “standing still.” This may cause the antenna to track improperly. To solve this problem, turn TracVision L3 off for at least 10 seconds. Turn the system back on, making certain that the vehicle is either motionless or travelling in a straight line for the 60 seconds immediately following power-up.

4.1.7 Incorrect or Loose RF Connectors

As part of preventive maintenance (described in [Section 5, “Maintenance,”](#)) KVH recommends checking the Antenna Unit cable connections. A loose RF connector can reduce the signal quality. Refer to [Section 2.3.6, “Connecting the Antenna RF Signal Cable to the IRD”](#) for directions on proper Antenna Unit to RF cabling.



Baseline RF levels are included as part of the startup sequence provided in [Appendix E](#).

4.1.8 Using a Passive Multiswitch (North American Systems Only)

An active multiswitch must always be used to connect the TracVision L3 system to multiple IRDs. Refer to [Section 2.3.6, “Connecting the Antenna RF Signal Cable to the IRD”](#) for directions on proper multiswitch/multiple IRD cabling.

4.2 IRD Troubleshooting

The IRD that was provided with your satellite television service may also be the cause of less-than-ideal operation.

4.2.1 IRD Wiring

Refer to [Section 2.3.6, “Connecting the Antenna RF Signal Cable to the IRD”](#) and your IRD user manual to confirm that the IRD is properly connected to the Antenna Unit and the television.

4.2.2 IRD Faulty

In the case of a faulty IRD, refer to your IRD user manual for service, replacement, and warranty information.

4.3 Antenna Gyro and LNB Faults

[Section 5, “Maintenance,”](#) provides detailed instructions for authorized service personnel who may be required to replace the TracVision L3 antenna gyro or the LNB.

4.4 Computer Diagnostics

TracVision L3 has been designed to provide diagnostic readouts viewed on the TV screen (DIRECTV only) or on a personal computer having an RS-232 serial communication port. If you are unable to isolate a system problem with the foregoing troubleshooting tools, set up a laptop to carry out computer diagnostics as described on the next page. System problems will most likely be found somewhere through the diagnostic readouts.

The diagnostics procedure requires terminal emulation software such as PROCOMM, Windows Terminal, or Windows 95/98 Hyperterminal. Use the settings appropriate to your application.

1. Connect one end of the PC data cable to the DB9 connector on the switchplate. Connect the other end to the serial port on the PC (a 9-pin/25-pin connector adapter may be needed for some PCs).
2. Open the terminal emulation software and establish the following settings:
 - 9600 baud
 - no parity
 - 8 data bits
 - 1 start bit
 - 1 stop bit
 - no flow control
3. Apply power to the TracVision L3 system and allow the system to complete full initialization. Data should be scrolling on the PC display to identify any system problems detected. If no data is seen, recheck your connections and the terminal software setup.

4.5 Maintenance Port Parser Commands

TracVision L3 system parser commands are detailed in [Appendix F](#).

5 Maintenance

5.1 Warranty/Service Information

KVH Industries, Inc. warrants the KVH product purchased against defects in materials for a period of TWO (2) years and against labor costs for a period of ONE (1) year from the date of original retail purchase by the original purchaser. It is the customer's responsibility to verify the date of purchase by returning the warranty card included with the product to KVH within 30 days of purchase, or by providing a copy of a dated sales receipt for the KVH product under warranty with the warranty claim. If this date cannot be verified, the warranty period will begin 30 days after the date of manufacture of the original product purchased.

For additional information on KVH warranty, repair, and liability policies, please refer to the warranty statement provided with your TracVision L3.



The serial number of your TracVision L3 will be required during any troubleshooting or service calls. You will find the serial number on the warranty card accompanying your system as well as in front of the antenna reflector on the rotating plate.

5.2 Preventive Maintenance

TracVision L3 requires minimal preventive maintenance. The following tasks are sufficient to maintain peak performance.

Monthly

- Wash the exterior of the radome and baseplate assembly with fresh water; a mild detergent may be added to remove grime. Do not spray the radome directly with high-pressure water.
- Do not apply abrasive cleaners or volatile solvents such as acetone to the ABS radome.

Annually

- Remove the radome and examine the interior of the Antenna Unit for signs of corrosion, loose connections, or frayed or broken wires.
- Visually inspect the elevation drive shaft to be certain that it moves easily and is clear of grit and debris. Clean and lubricate as required.

5.3 Replaceable Parts



To help us continually improve the quality and reliability of our systems, please return any failed component to KVH or KVH Europe after you receive your replacement part.

TracVision L3 has been designed with durability and low maintenance in mind. If you experience an operating problem or otherwise require technical assistance, contact your local authorized TracVision L3 dealer/distributor first. Have the Antenna Unit serial number ready with a list of the trouble symptoms. If an authorized dealer/distributor is not located nearby, contact the factory directly at the telephone, facsimile, or e-mail listings inside the front cover.

Replacement part numbers for units that can be serviced in the field are listed in Table 5-1. These parts may be obtained from any KVH authorized dealer/distributor.

Table 5-1
Field Replaceable Units



Should the fuse ever need to be replaced, TracVision L3 uses a 5x20mm, 4-amp, 250-volt fast-blow fuse.

Part Name	Part Number
Baseplate Assembly	02-1044-01
Radome Assembly	02-0953-03
Power Cable	32-0590-30
Antenna Data Cable	32-0630-30
RF Cable	32-0589-30
PC Cable	32-0628-06
CPU PCB	02-1043-02
RF PCB	02-1017-02
Antenna Gyro	02-1035
Antenna Gyro Gasket	24-0139
System Fuse	16-0017-4000
LNB (European System)	19-0196
LNB (N. American System)	19-0056
Switchplate	02-1023

It is recommended that all other technical difficulties be resolved by returning the TracVision L3 unit to an authorized service provider.

5.4 Field Replaceable Unit Procedures

The following subsections provide detailed procedures for repairing or swapping out field replaceable units. The procedures refer to labeled items presented on the following isometric diagrams, which are based on KVH assembly drawings.



Always lift the Antenna Unit by the gray baseplate, never by the radome or any portion of the antenna assembly!

Figure 5-1
Antenna, PCB, and Rotating Plate

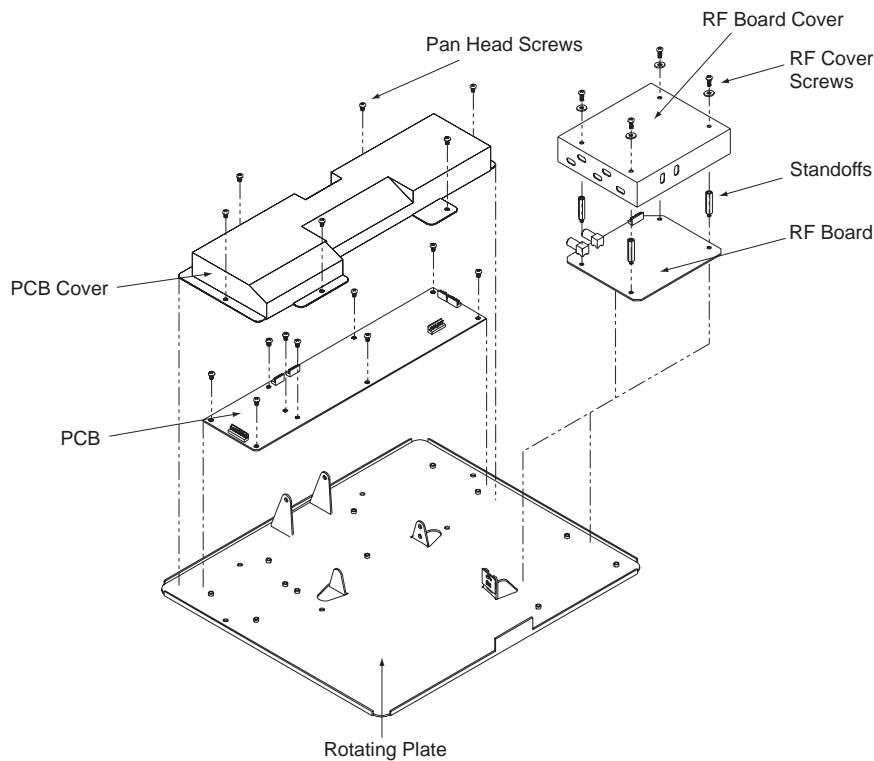

Figure 5-2
Close-up of Linear Actuator, Pivot Bracket, and Pin

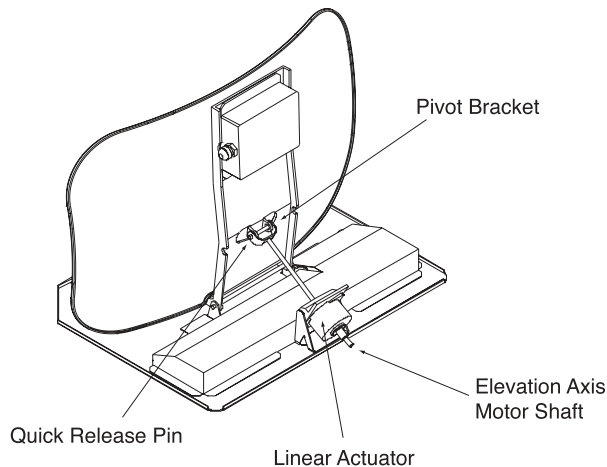

Figure 5-3
Antenna Assembly

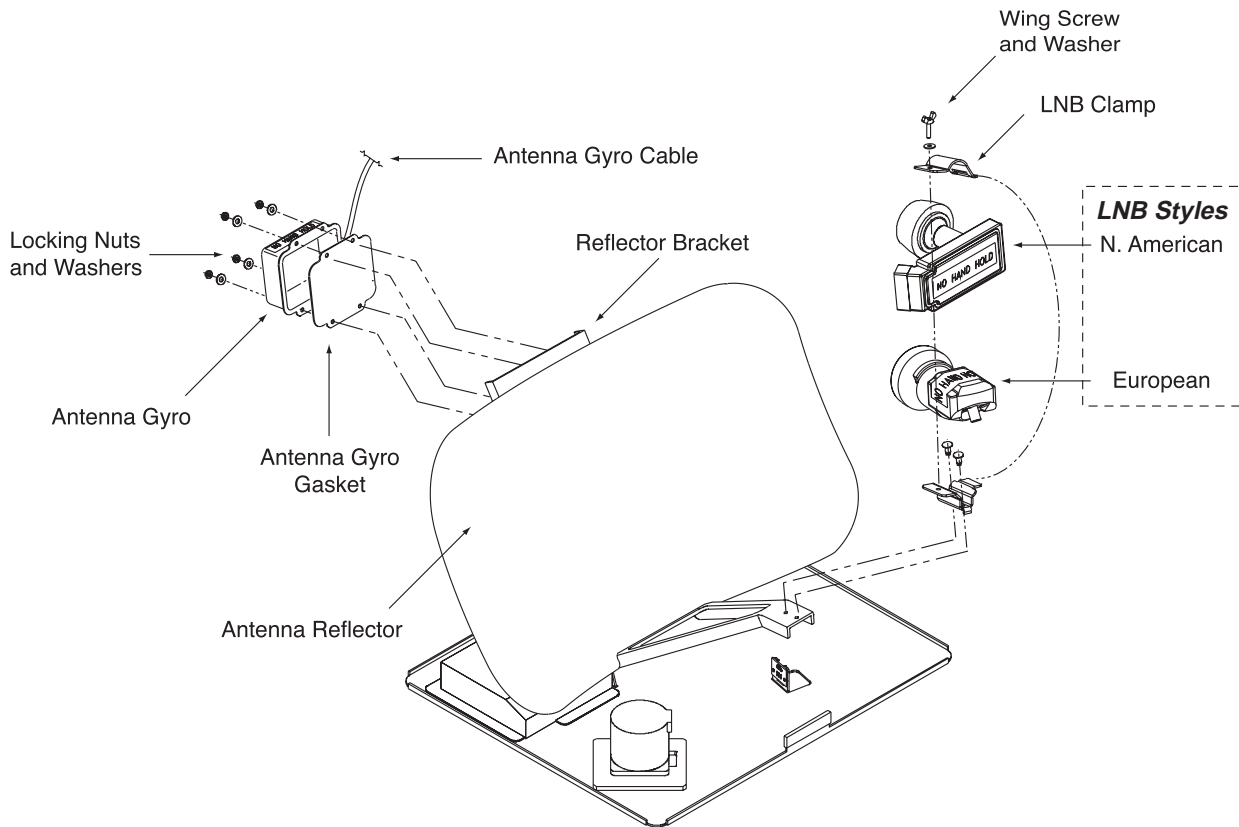
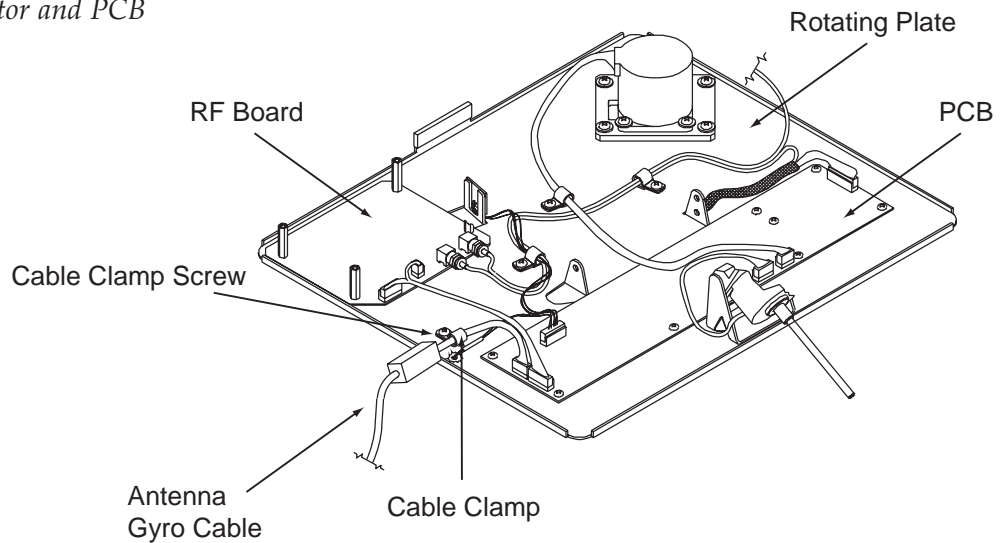

Figure 5-4
Close-up of RF Detector and PCB



5.4.1 PCB Removal and Replacement

Estimated Time to Repair: ½ hour

The microprocessor PCB assembly is protected by a cover fastened to the rotating plate – *Fig. 5-1*. The cover must be removed to gain access to the main power fuse and the PCB assembly.

1. Remove the quick release pin from the pivot bracket – *Fig. 5-2*.
2. Remove the elevation axis motor shaft from the linear actuator – *Fig. 5-2*.
3. Remove the 6 pan head screws from the PCB cover flanges. Remove the PCB cover – *Fig. 5-1*.
4. Remove cable connectors from PCB. Figure 5-5 illustrates the PCB arrangement and connector locations.

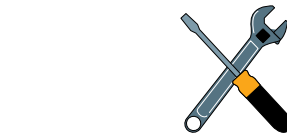
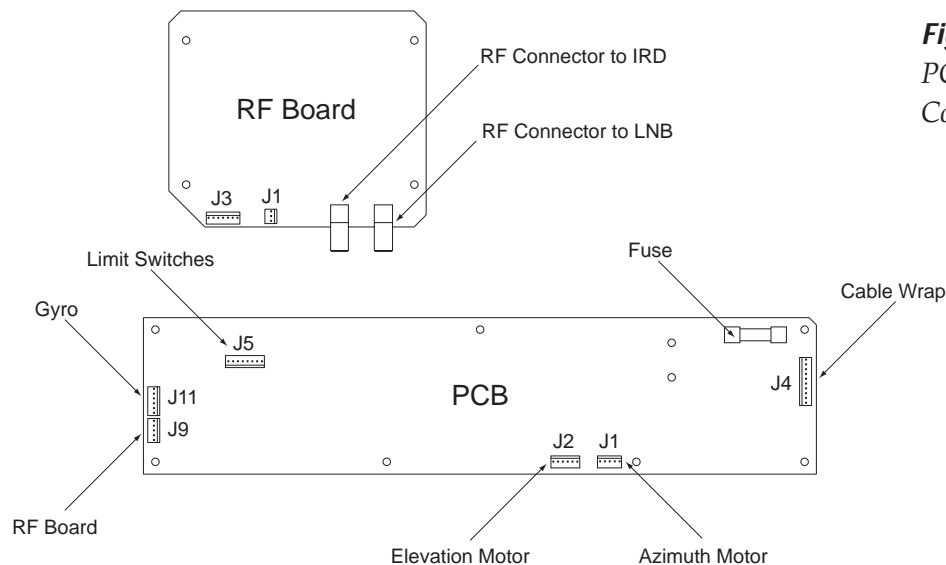

When carrying out maintenance on the PCB, be sure to not drop any of the small screws inside the mechanism. If a screw is lost within the baseplate, it must be retrieved to avoid causing any damage when the unit rotates.

Figure 5-5
PCB and RF Detector Board
Connector Locations

5. The PCB is mounted to the rotating plate with 9 pan head screws. Remove the screws and PCB.
6. Reverse this process to install the replacement PCB. Reinstall all cable connectors removed in Step 4.
7. Carry out all calibration procedures for the antenna gyro (*Section 5.4.3*).
8. Reinstall your preferred satellites as detailed in *Section 2.4.1, Installing Your Selected Satellites*.



TracVision L3 is equipped with a 5x220 mm, 4-amp, 250 volt fast-blow fuse, which is mounted on the PCB. To access and replace the fuse, follow the directions to remove the PCB cover and then swap the blown fuse for a new one.

5.4.2 RF Detector/DVB Decoder

Estimated Time to Repair: ½ hour

The RF Detector PCB receives operating voltages from both the CPU board and the IRD (via the RF cable) – *Fig. 5-1*. Ensure that all power is turned off before proceeding.

1. Remove the 4 RF board cover screws and washers from the RF board cover.
2. Remove the RF board cover.
3. Remove 2 RF connectors from the coaxial fittings on the PCB. Tag the cables to ensure that they are returned to the same connectors.
4. Remove the Molex connectors from J3 and J1 – *Fig. 5-5*.
5. Remove the 4 standoffs – *Fig. 5-1*. Remove the RF Detector PCB from the rotating plate.
6. Installation of the replacement RF Detector is the reverse of this procedure. Be sure that the RF cables are restored to their original positions. Be sure that the center conductor pin is centered in the connector before tightening the collar.

5.4.3 Antenna Gyro Assembly

Estimated Time to Repair: 1 hour



Following the removal and replacement of the antenna gyro assembly, it will be necessary to calibrate the gyro and restart the system.

The antenna gyro is mounted on the rear of the antenna reflector bracket with four locking nuts and washers – *Fig. 5-3*. Following the removal and replacement of the antenna gyro assembly, it will be necessary to calibrate the gyro and restart the system.

Directions for removal, replacement, and calibration follow:

1. Remove the quick release pin from the pivot bracket – *Fig. 5-2*.
2. Remove the elevation axis motor shaft from the linear actuator – *Fig. 5-2*.
3. Remove the 6 pan head screws from the PCB cover flanges. Remove the PCB cover – *Fig. 5-1*.
4. Remove the screw and clamp holding the antenna gyro cable to the rotating plate. Be sure to save the cable clamp and screw – *Fig. 5-4*.

5. Remove the Molex connector from J11 on the CPU board – *Fig. 5-5*.
6. Remove the 4 nuts and washers and take the gyro off of the bracket.
7. Remove the antenna gyro gasket.
8. Replacement is the reverse of this procedure.

Antenna Gyro Calibration

1. Connect a PC to the communications port as described in *Section 4.4, “Computer Diagnostics.”*
2. Type **HALT<cr>** while the system is performing the limit switch initialization routine. The system will complete the initialization function by finding the azimuth and elevation switch limits and then go to the home position.
3. Type **DEBUGON<cr>** to enter Debug Mode.
4. Type **=CALGYRO<cr>**. Verify that the Antenna Gyro Azimuth scale factor is between -0.00090 and -0.00110 and the Antenna Gyro Elevation scale factor is between 0.00090 and 0.00110.
5. Type **ZAP** to restart/reinitialize the system.

5.4.4 Antenna LNB Replacement

Estimated Time to Repair: ½ hour

In the event that the LNB experiences problems, it may be necessary to replace it. To do so, use the following procedure:

1. Make a note of the current LNB skew angle, pictured in Figure 5-6 (*European systems only*).
2. Disconnect the RF cable connector at the LNB.
3. Remove the wing nut and washer from the LNB clamp – *Fig. 5-3*.
4. Remove the top of the LNB clamp and remove the LNB.
5. Place the new LNB in the clamp and reattach the RF connector.



The LNB receives power from the IRD via the RF Detector PCB. Be certain that the IRD is disconnected from its power source before removing or reconnecting the LNB.

Figure 5-6
LNB Skew Angle Setting
(European Systems Only)

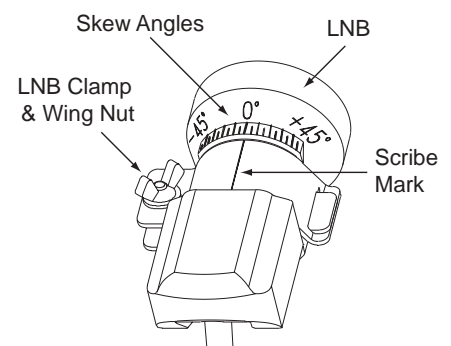

6. Replace the LNB clamp:
 - A. For North American LNBs, tighten the clamp fully. The replacement process is complete.
 - B. For European LNBs, do not fully tighten the clamp and proceed to step 7.
7. Carefully turn the LNB so that the scribe mark is aligned with the skew angle noted in Step 1. Fully tighten the clamp to complete the replacement process.



When rotating the azimuth mechanism by hand, go slowly! Hitting the mechanical stops with excessive force will damage the azimuth limit switch.

5.5 Preparation for Shipment

If it is necessary to repack the Antenna Unit for shipment, the shipping restraints removed during installation must be replaced. Follow these steps to reinstall the restraints.

1. Rotate the antenna unit so that the LNB is facing forward (away from the liquid-tight fittings).
2. Attach the three restraints to the baseplate using the 1/4"-20 x 5/8" long hex screws and washers (provided as part of the kitpack), and nuts (removed from shipping restraint during installation) as pictured in Figure 5-7.

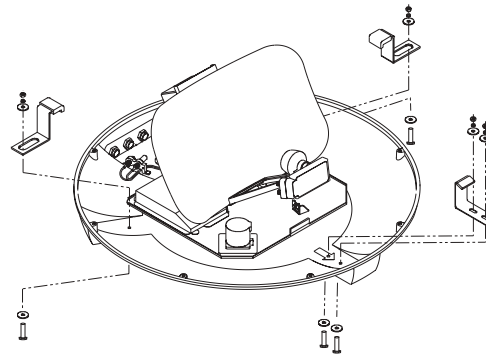

Figure 5-7
Attaching the Shipping Restraints to the Antenna Baseplate

3. Place the antenna bracket on the forward shipping restraint.
4. Secure the forward restraint and bracket by wrapping two tie-wraps around the bend in the forward restraint and the antenna bracket (at the end of the LNB bracket).

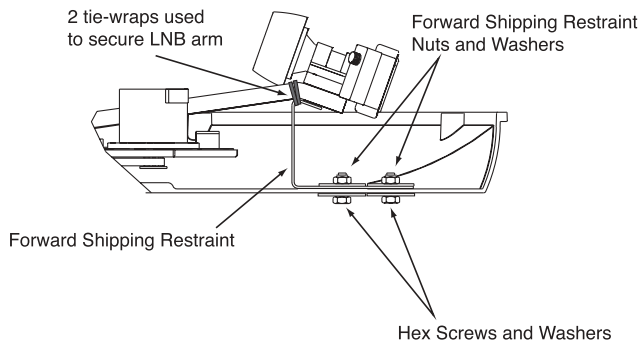

Figure 5-8
Securing the Forward Shipping Restraint

5. Place the entire Antenna Unit into its shipping box using the original packaging material, as illustrated in Figure 5-9.

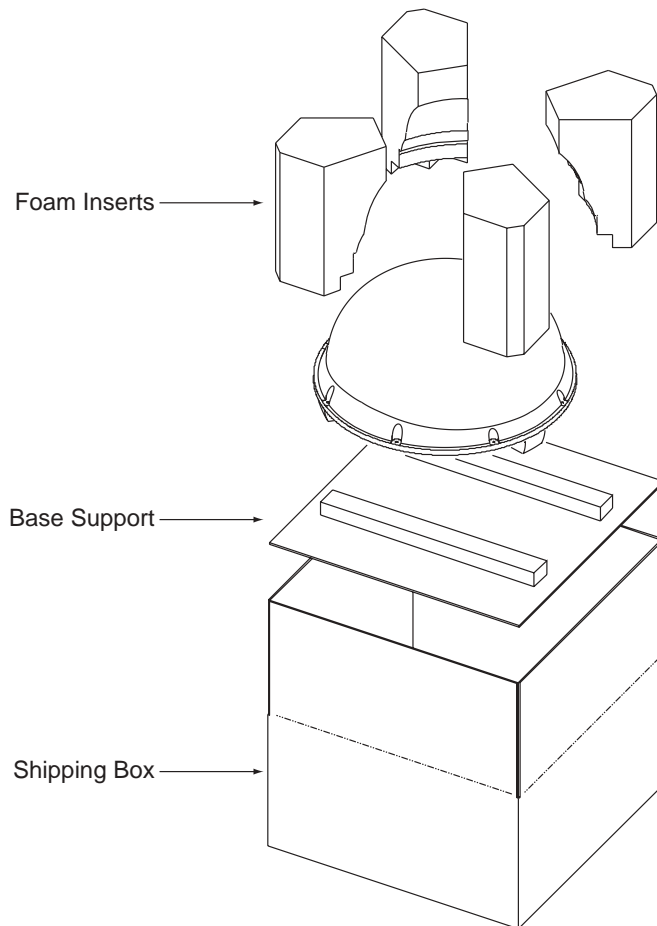

Figure 5-9
Repackaging the TracVision L3

Appendix A

System Specifications

Physical Characteristics

Power	11-16 volts DC @ 2.5 amps nominal, 3.5 amps peak
Dimensions/Weight	32" (81 cm) wide x 14.5" (37 cm) high, 33 lbs (15 kg)
LNB	European System: Single Output N. American System: Dual Output
Tracking	Better than 30°/sec
Maintenance Port	9600 bps, 8,N,1,EIA, RS232

Table A-1

*TracVision L3 System
Specifications*

Pointing System

Elevation Range	15° to 75°
Azimuth Range	720°
Position Repeatability	0.1°

Environmental

Operating Temperature	-25°C to +55°C
Storage Temperature	-40°C to +85°C
Humidity	to 100 percent

Appendix B

Functional Block Diagram

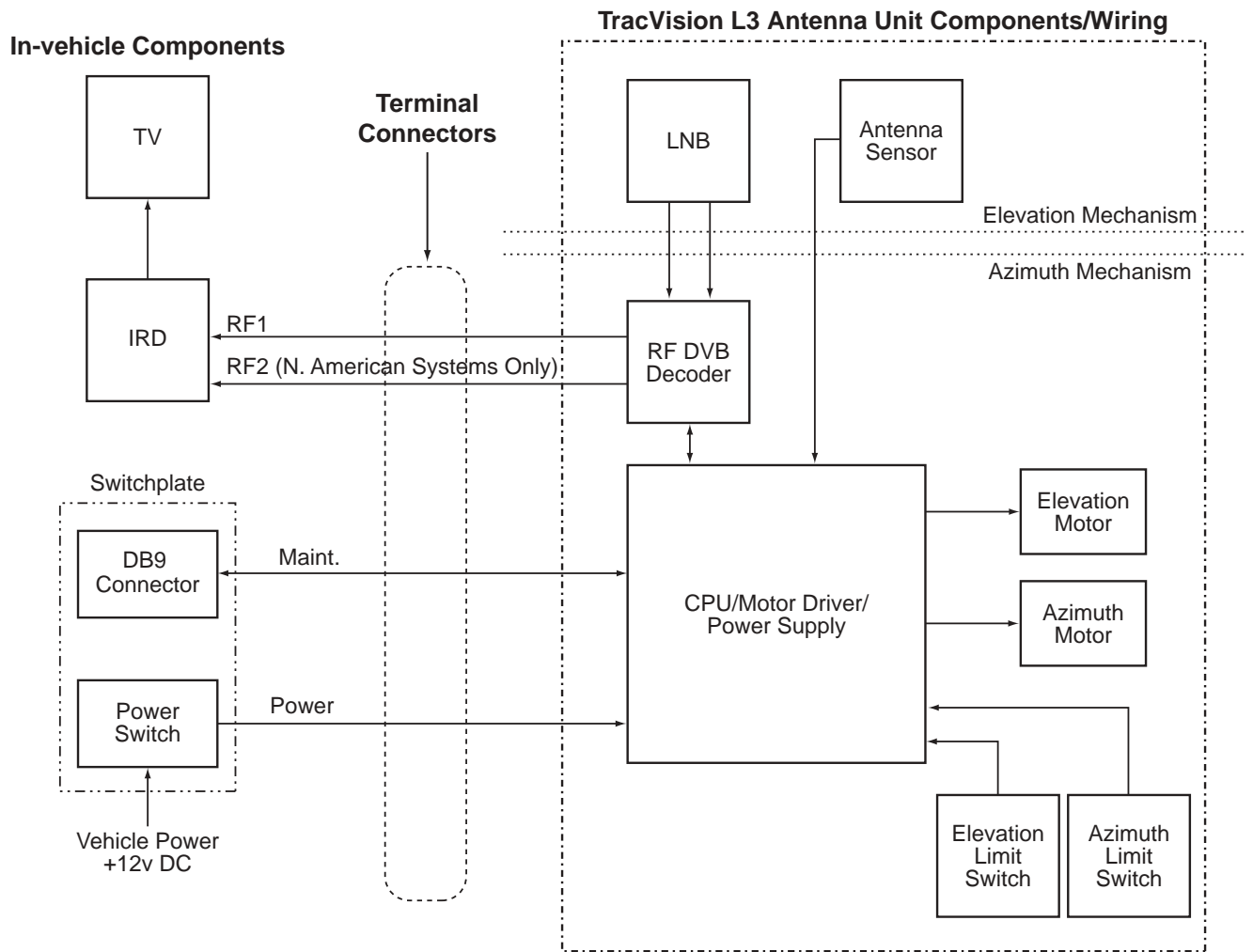

Cable Assignments

- RF1.....RF Cable (32-0589-30)
- RF2.....Owner-provided RG-6 or RG-11 (75 ohms) cable (North American systems only)
- IRD/Maint.....Antenna Data Cable (32-0630-30)
- Power.....Power Cable (32-0590-30)

Appendix C

Switchplate Template

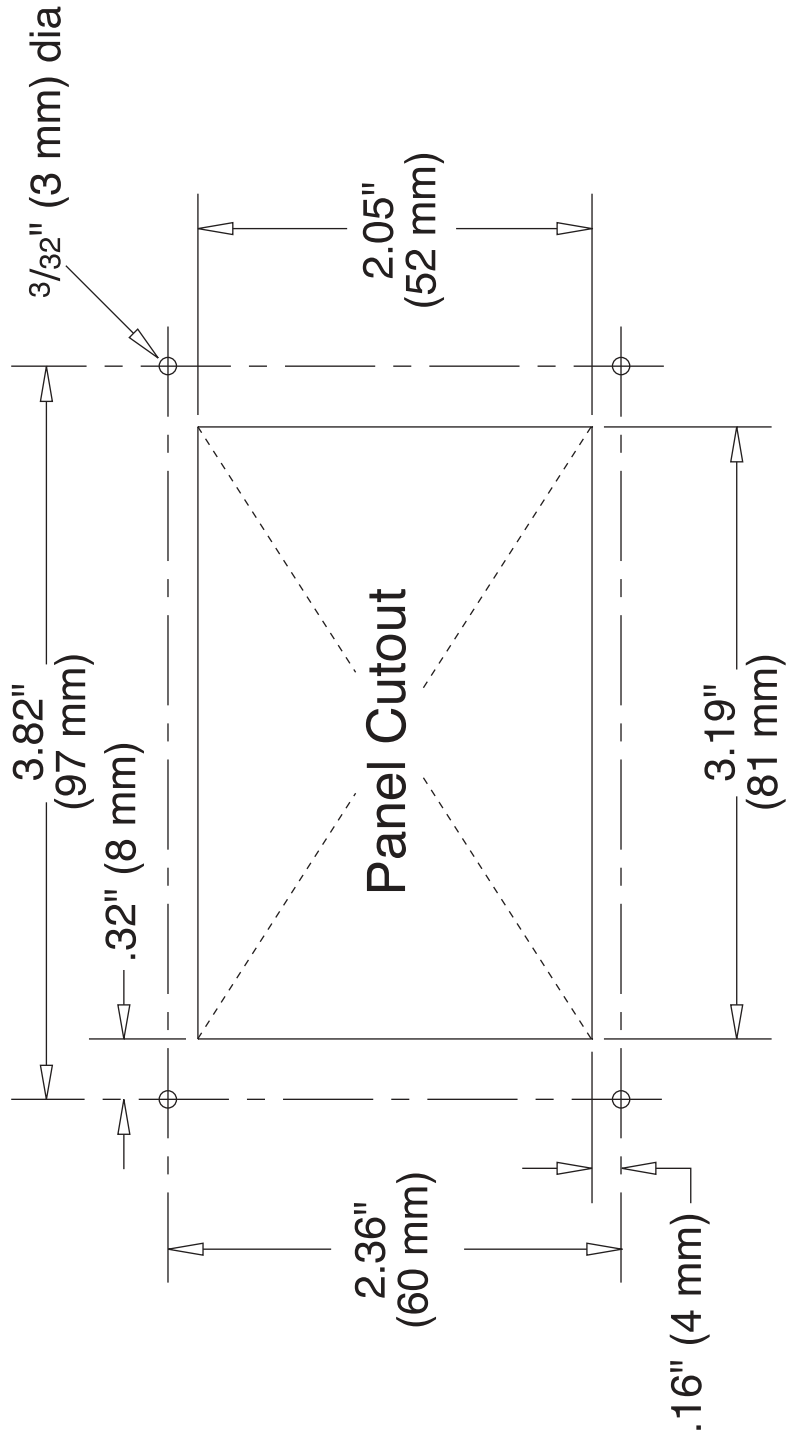

Appendix D

Predefined Satellite Configurations

As noted previously, your TracVision L3 comes programmed with the satellite configurations for seven European and eight North American satellite services. For your reference, those configurations are listed below. These configurations are current as of July 1, 2001, and are subject to change by the satellite service providers.

European Satellites

Satellite	F,S,C,ID,P,B,D	Configuration Definitions
Astra 1	11778,27500,34,0x0020,V,H,3 11742,27500,34,0x0020,V,L,3 12344,27500,34,0x0035,H,H,3 11876,27500,34,0x0020,H,L,3	<i>F</i> = Frequency <i>S</i> = Transponder symbol rate <i>C</i> = FEC code
Astra 2N	11778,27500,23,0x0020,V,H,3 00000,27500,34,0x0000,V,L,3 11914,27500,23,0x0020,H,H,3 00000,27500,34,0x0000,H,L,3	<i>ID</i> = Satellite network ID <i>P</i> = LNB polarization (vertical or horizontal)
Astra 2S	11817,27500,23,0x0020,V,H,3 00000,27500,34,0x0000,V,L,3 11798,27500,23,0x0020,H,H,3 00000,27500,34,0x0000,H,L,3	<i>B</i> = LNB band (high, low, or USA) <i>D</i> = Decoding type (3 = DVB)
Hispasat	12152,27500,34,0x0031,V,H,3 11660,27500,34,0x0031,V,L,3 12154,27500,34,0x0031,H,H,3 11522,27500,34,0x0031,H,L,3	
Hotbird	12073,27500,34,0x013E,V,H,3 11958,27500,34,0x013E,V,L,3 11862,27500,34,0x013E,H,H,3 11862,27500,34,0x013E,H,L,3	
Sirius	12130,27500,34,0x03E8,V,H,3 00000,27500,34,0x0000,V,L,3 12108,27500,34,0x0001,H,H,3 00000,27500,34,0x0000,H,L,3	
Thor	12226,28000,78,0x0046,V,H,3 11309,24500,78,0x0046,V,L,3 12322,27800,34,0x0046,H,H,3 11229,24500,78,0x0046,H,L,3	

North American Satellites

Satellite	F,S,C,ID,P,B,D
ExpressView	12603,20000,56,0X0100,V,U,3 12603,20000,56,0X0100,V,U,3 12384,20000,56,0X0100,H,U,3 12384,20000,56,0X0100,H,U,3
Echostar 61	12577,20000,34,0X1002,V,U,3 12577,20000,34,0X1002,V,U,3 12358,20000,34,0X1002,H,U,3 12358,20000,34,0X1002,H,U,3
Echostar 110	12456,20000,34,0X1006,V,U,3 12456,20000,34,0X1006,V,U,3 12383,20000,34,0X1006,H,U,3 12383,20000,34,0X1006,H,U,3
Echostar 119	12374,20000,34,0X1004,V,U,3 12374,20000,34,0X1004,V,U,3 12381,20000,34,0X1004,H,U,3 12381,20000,34,0X1004,H,U,3
Echostar 148	00000,20000,34,0X1004,V,H,3 00000,20000,34,0X1004,V,U,3 00000,20000,34,0X1004,H,H,3 00000,20000,34,0X1004,H,U,3
DIRECTV 101	12368,20000,67,0X0000,V,U,2 12368,20000,67,0X0000,V,U,2 12238,20000,67,0X0000,H,U,2 12238,20000,67,0X0000,H,U,2
DIRECTV 110	12456,20000,34,0X1006,V,U,3 12456,20000,34,0X1006,V,U,3 12383,20000,34,0X1006,H,U,3 12383,20000,34,0X1006,H,U,3
DIRECTV 119	12374,20000,34,0X1004,V,U,3 12374,20000,34,0X1004,V,U,3 12381,20000,34,0X1004,H,U,3 12381,20000,34,0X1004,H,U,3

Appendix E

Startup Data Sequence

The data on the following pages presents a standard startup data sequence registered by the TracVision L3. This sequence can be recorded using the data port and a PC.

```
?PGM
KVH TracVision L3 Rev X - Version X.XX - Serial Number XXXXXXXX
RF: ZAP
*** Initializing RF Controller ***
RF: S,A,H,U,V
RF: SATINSTALL,55,C,57,C
RF: L,B-----Identifies Satellite A or B as currently
RF: SATCONFIG                               loaded for acquisition
RF: F,A,12368,20000,67,0X0000,V,U,2-----Satellite configuration data, Satellite A
RF: F,A,12368,20000,67,0X0000,V,U,2
RF: F,A,12238,20000,67,0X0000,H,U,2
RF: F,A,12238,20000,67,0X0000,H,U,2
RF: F,B,12374,20000,34,0X1004,V,U,3-----Satellite configuration data, Satellite B
RF: F,B,12374,20000,34,0X1004,V,U,3
RF: F,B,12381,20000,34,0X1004,H,U,3
RF: F,B,12381,20000,34,0X1004,H,U,3
RF: RF PCB Version X.X-----Current RF software revision
RF: S,B,H,U,V
RF: I,0,48960,00000,00433,0
RF COMM: PASS-----PASS is expected
RF: S,B,H,U,V
*** Initializing Antenna ***
GPS: UTC: 083000.00, Lat: 4131.00N, Long: 7115.00W
GPS: DSS_119 AZ = 238.9, EL = 22.1
GPS: DSS_101 AZ = 220.9, EL = 33.4
Limit Switch Test
Limit Switch Status: PASS-----PASS is expected
RF: S,B,H,U,V
*** Initializing Rate Bias ***
RF: S,B,V,U,V
+A/D: 1992 2033 601
RF: S,B,H,U,V
Gyro Bias: Az = 1991.95, El = 2032.05-----Expected range is 1700-2300
Gyro Uncertainty: Az = 3.00, El = 3.00
*** Limit Switch Search ***
RATE BIAS: PASS-----PASS is expected
Searching for DSS_119, Threshold = 1000
+POS: 80.5 25.9 273
RF: S,B,H,U,V
+POS: 11.3 25.9 513
RF: S,B,V,U,V
+POS: 300.8 25.9 162
RF: S,B,V,U,V
Satellite Found: AZ = 231.1, EL = 25.9, RF = 1793
+POS: 230.4 25.9 1963
```

```
*** Entering Tracking ***
RF: S,B,H,U,V
+POS: 231.5 26.2 1334
+POS: 231.3 25.8 2023
+POS: 230.6 24.4 2741
RF: Freeze DAC = -00652
+POS: 230.1 23.9 2829
*** Network ID Check ***-----Comparing the tracked satellite's network ID to the
+POS: 230.0 23.5 2843                               selected satellite's network ID
RF: Y,0X1004-----Indicates positive satellite identification
*** Tracking DSS_119 ***-----Identifies satellite currently tracked
+POS: 229.0 22.6 3010                               (TV broadcast image should be available)
+POS: 229.5 23.1 2935
+POS: 228.6 22.7 2940
+POS: 229.5 22.8 2881
+POS: 228.5 22.9 2835
Saved Sat Pos: AZ = 228.91, EL = 22.86
RF: AGCON
RF: AGC=51528
Gyro Bias Residue: Az = 2.5363e-01 EL = -6.1966e-01
+POS: 229.3 22.7 2520
+POS: 228.6 23.3 2516
Conscan=>sleep: sat in 1 deg window.
Sleeping
Old Gyro Bias: Az = 1991.95 EL = 2032.05
New Gyro Bias: Az = 1991.70 EL = 2032.67
```

Appendix F

Maintenance Port Parser Commands

TracVision L3 system parser commands are parsed when the system receives an ASCII carriage return (Hex 0D). An ASCII line feed (Hex 0A) is permitted but is ignored in any transmitted command. All system responses are terminated with an ASCII carriage return followed by a line feed and ending with either an acknowledge character (ASCII > (Hex 3E)) or a not-acknowledge character (ASCII ? (Hex 3F)). The parser commands are shown below in boldface capital letters but they are not case-sensitive. In most cases the command is responded to with an echo; that is, if you type **ZAP**, for example, and press “ENTER” the response will be the command you have entered. For other commands the response is specific for each command, such as **VERSION**, **STATUS** or **HELP**.

F.1 System Commands

Software Version

Function:	reports software version and system type
Command:	VERSION
Argument:	none
Response:	KVH TracVision L3 Version XX.XX

Table F-1
System Commands

System Status Report

Function:	reports general system status
Command:	STATUS
Argument:	none
Response:	system status string

Initialize the System

Function:	initializes the system (perform a soft reset)
Command:	ZAP
Argument:	none
Response:	echoes the command, then reinitializes the system

Calibrate Gyro

Function:	performs azimuth and elevation calibration
Command:	CALGYRO
Argument:	none
Response:	echoes command and calibrates gyro

Find Skew Angle for Currently Selected Satellite

Function:	calculates necessary LNB skew based on latitude, longitude, and selected satellite
Command:	SKEWANGLE*
Argument:	none
Response:	displays skew angle

* Before this command can function properly, you must perform the GPS Position command detailed in Section F.6 to provide the system with the proper latitude and longitude.

Help on Parser Commands

Function:	lists parser commands
Command:	HELP
Argument:	none
Response:	print a list of all parser commands

F.2 Manual Positioning Commands

To execute the following commands, first put the Antenna Unit in idle mode by typing **HALT** and pressing "ENTER." Positioning commands may be entered after the antenna comes to rest.

Table F-2
Manual Positioning Commands

Azimuth Angle

Function:	commands a manual azimuth angle that the mechanism moves to
Command:	AZ,xxxx (range is 0000-3599)
Argument:	desired azimuth angle of the mechanism relative to external magnetic reference, or baseplate fwd, 000°-359.9°
Response:	echoes the command; mechanism moves at a fixed velocity

Elevation Angle

Function:	commands a manual elevation angle that the mechanism moves to
Command:	EL,xxx (range is 100-850)
Argument:	desired elevation angle of the mechanism relative to up, 10.0°-85.0°
Response:	echoes the command; mechanism moves at a fixed velocity

Azimuth CW Step

Function:	commands a 0.1 deg CW manual step in azimuth angle
Command:	6
Argument:	none
Response:	echoes the command

Azimuth CCW Step

Function:	commands a 0.1 deg CCW manual step in azimuth angle
Command:	4
Argument:	none
Response:	echoes the command

Elevation UP Step

Function:	commands a 0.1 deg UP manual step in elevation angle
Command:	8
Argument:	none
Response:	echoes the command

Elevation DOWN Step

Function:	commands a 0.1 deg DOWN manual step in elevation angle
Command:	2
Argument:	none
Response:	echoes the command

F.3 Operational Commands

To execute the following commands, first put the Antenna Unit in idle mode by typing **HALT** and pressing "ENTER." After the system comes to a halt, type **DEBUGON** and press "ENTER" to enter programming mode.

Table F-3
Operational Commands

Tracking Mode	
Function:	starts active tracking of the satellite
Command:	TRACK
Argument:	none
Response:	echoes the command
Idle Mode	
Function:	halts active tracking and conical scan, then enters idle mode
Command:	HALT
Argument:	none
Response:	echoes the command
Current Cable Wrap Angle	
Function:	sets or reports current cable wrap angle, defined as 0° (CCW limit) to 700° (CW limit); the value is expressed as 0000-7000 with an implied decimal
Command:	WRAPANGLE,xxxx
Argument:	the desired cable wrap angle setting
Response:	Wrap Angle = xxxx

F.4 Tracking and Conical Scan Commands

Table F-4
Tracking and Conical Scan Commands

Target Location	
Function:	reports the target location in antenna frame. Data format is E### for elevation in degrees 000-900 and A##### for azimuth in degrees 0000-3599 with implied decimals
Command:	TGTLOCATION
Argument:	none
Response:	Target Location = A = E###, A##### B = E###, A#####

Analog Signal Strength Report

Function:	reports signal strength from RF detector circuit in A/D counts (000-FFF Hex)
Command:	SIGLEVEL
Argument:	none
Response:	Signal Strength = xxxx

F.5 RF Board Commands**Serial Communications, Status/Polarization Report, Tone Changes****Table F-5***RF Board Commands*

Function:	start serial communications, reports status & polarization/tone changes
Command:	@S
Response:	S,s,p,b,m <cr> every 5 seconds until ><cr>is returned from system software
Where:	s = Satellite (a = Primary, b = Secondary) p = Polarization (v = Vertical, h = Horizontal, x = No LNB Power) b = Band (h = High Band, l = Low band, u = USA) m = Mode (v = Valid, i = Invalid)*

* The Mode bit is used to evaluate the Satellite, Polarization, & Band combination vs. the Frequency/Symbol Rate/FEC currently in RAM. This bit will be set to invalid if the Frequency for the selected combination is set to 0x0000; otherwise it will be set to valid.

Report RF Tracking Parameters

Function:	reports all RF tracking parameters for primary & secondary satellites*
Command:	@SATCONFIG
Response:	F,x,ffff,S,C,ID,P,B,D <cr>
Where:	x = Satellite (a = Primary, b = Secondary) ffff = Frequency in MHz (00000 and 10700 to 12700) S = Symbol rate in Mbit/Sec (1000 to 29999) C = FEC code rate (valid rates = 12, 23, 34, 56, 67, 78) ID = Satellite Network ID in hexadecimal format (valid range = 0x0000 to 0xffff hex) P = LNB Polarization (v = Vertical, h = Horizontal) B = the LNB down conversion frequency (l = low, h = high, u=USA) D = decoding type (0 = test, 1 = DSS-A, 2 = DSS-B, 3 = DVB)

* This command dumps all eight combinations of the Satellite /Freq/Sym/FEC/ID/POL/Band/Decode currently stored in RAM.

Set RF Tracking Parameters

Function:	sets RF tracking parameter
Command:	@SATCONFIG,X,N,F,S,C,ID,P,B,D<cr>
Response:	Echoes the input data
Where:	<p>@SATCONFIG = directs data to the RF Board</p> <p>X = satellite location A or B</p> <p>N = satellite table # (98 & 99 are slots for user-configured satellites)</p> <p>F = frequency in MHz (either 00000 or a range from 10700 - 12700)</p> <p>S = the satellite transponder symbol rate in Mbit/second (01000 - 29999)</p> <p>C = the FEC code (e.g., 12, 23, 34, 56, 67, 78)</p> <p>ID = the satellite network ID in hexadecimal format (0x####)</p> <p>P = the LNB polarization (v=vertical, h=horizontal)</p> <p>B = the LNB down conversion frequency (l=low, h=high, u=US)</p> <p>D = decoding type (0=test, 1=DSS-A, 2=DSS-B, 3=DVB)</p>

ID Match/Decoded Network ID

Function:	report ID match and decoded network ID
Command:	@CHECKID
Response:	<p>Y,0X####</p> <p>N,0X####</p> <p>Y,NoID</p> <p>N,NoID</p>
Where:	<p>Y = yes</p> <p>N = no</p> <p>0X#### = network ID</p> <p>NoID = satellite unidentified</p>

F.6 Installation Commands

To execute the following commands, first put the Antenna Unit in idle mode by typing **HALT** and pressing "ENTER." After the system comes to a halt, type **DEBUGON** and press "ENTER" to enter programming mode.

Select Active Satellite

Function:	switch antenna tracking to/from satellite A and B
Command:	@L,x
Where:	x = A or B (as defined during the SATINSTALL process)

Table F-6*Installation Commands***Set/Report GPS Position**

Function:	reports or sets default GPS position
Command:	GPS<cr> GPS,XX,D,YYY,E
Response:	GPS = XXD YYYY<cr> GPS: XXD YYYY
Where:	XX = latitude (0-90) D = S (South) or N (North) YYY = longitude (0-180) E = E (East) or W (West)

Report Satellite Names

Function:	report names for satellites A and B
Command:	SATINSTALL
Response:	SATINSTALL,<sat_a_name>,<sat_b_name>

Report Configured Satellite Names

Function:	report names for all configured satellites
Command:	SATLISTA
Response:	SATLISTA,<sat_name1>,...,<sat_nameX>

Report Valid Satellite B Selections

Function:	report names for all valid satellite B selections for a given satellite A selection
Command:	SATLISTB,<sat_a_name>
Response:	SATLISTB,<sat_a_name>,<sat_b_name1> ...,<sat_b_nameX>

Install Satellite Pair

Function:	installs satellites A and B as the satellite pair
Command:	SATINSTALL,<sat_a_name>,<sat_b_name>
Response:	If valid pair, echoes the input data If invalid pair, returns error message

Configure Longitude of a User-configurable Satellite

Function:	configures one of the user-configurable satellites with the longitude provided
Command:	SATCONFIG,USERX,YYY,Z,D,L
Response:	If valid pair, echoes the input data If invalid pair, returns error message
Where:	X = 1 or 2 YYY = longitude (0-180) Z = E (East) or W (West) D = decoding type (0=test, 1=DSS-A, 2=DSS-B, 3=DVB) L = LNB polarization (c=circular, l=linear)

F.7 Debug Commands

*Table F-7
Debug Commands*

Report Offset Angles

Function:	reports system offset angles
Command:	OFFSETS OFFSETS,XXXXX,YYYY
Response:	Offsets= XXXXX.X XXXXX.X
Where:	X = new azimuth offset (-1800 - 1800) Y = new elevation angle (-450 - 450)

Applies Default Values to Default Satellites

Function:	updates the default satellites to the default values
Command:	SATPAIR,X
Response:	displays numerous frequency commands and reports "Satellite Installation Complete"
Where:	X = 0 (satellites default to Astra & Hotbird) or X = 1 (satellites default to Expressvu and EchoStar 119) or X = 2 (DSS 101 and DSS 119)

Report Last Satellite Tracked/Update Value

Function:	reports the last satellite tracked or updates the last tracked satellite to the value input if it is different from the current value
Command:	LASTSAT LASTSAT,X
Response:	Last = <sat_name>
Where:	X = A (updates to satellite A) or X = B (updates to satellite B)

KVH Industries Limited Warranty

TracVision L3

Limited Warranty on Hardware

KVH Industries, Inc. warrants the KVH product purchased against defects in materials for a period of TWO (2) years and against labor costs for a period of ONE (1) year from the date of original retail purchase by the original purchaser. It is the customer's responsibility to verify the date of purchase by returning the warranty card included with the product to KVH within 30 days of purchase, or by providing a copy of a dated sales receipt for the KVH product under warranty with the warranty claim. If this date cannot be verified, the warranty period will begin 30 days after the date of manufacture of the original product purchased.

If you discover a defect, KVH will, at its option, repair, replace or refund the purchase price of the product at no charge to you, provided you return it during the warranty period, transportation charges prepaid, to the factory direct. Please attach your name, address, telephone number, a description of the problem and a copy of the bill of sale or sales receipt as proof of date of original retail purchase, to each product returned to warranty service. Alternatively, you may bring the product to an Authorized KVH dealer/distributor for repair. If the product was installed by an Authorized KVH dealer/distributor (identified with the KVH Authorized dealer/distributor list), KVH will cover the dealer's/distributor's labor charges for warranty repairs, provided the dealer/distributor contacts KVH for pre-approval of the charges.

This Limited Warranty does not apply if the product has been damaged by accident, abuse, misuse or misapplication or has been modified without the written permission of KVH; if any KVH serial number has been removed or defaced; or if any factory-sealed part of the system has been opened without authorization.

Return Authorization

A Return Material Authorization is required prior to returning the product to KVH Industries. Please call our Technical Support Department at +1 401 847-3327 or send an e-mail to techs@kvh.com to obtain the RMA number. Write the number in large, clear characters on the outside of the box. To avoid confusion and misunderstandings, shipments without an RMA number clearly visible on the outside box will be refused and returned to you at your expense. If possible, use the original box and packing material to protect the equipment from damage in shipment. KVH assumes no responsibility for warranty shipments from the customer to the factory if not shipped in the manner prescribed above.

THE EXPRESS WARRANTIES SET FORTH ABOVE ARE THE ONLY WARRANTIES GIVEN BY KVH WITH RESPECT TO ANY PRODUCT FURNISHED HEREUNDER; KVH MAKES NO OTHER WARRANTIES, EXPRESS, IMPLIED OR ARISING BY CUSTOM OR TRADE USAGE, AND SPECIFICALLY DISCLAIMS ANY WARRANTY OF MERCHANTABILITY OR OF FITNESS FOR A PARTICULAR PURPOSE. SAID EXPRESS WARRANTIES SHALL NOT BE ENLARGED OR OTHERWISE AFFECTED BY TECHNICAL OR OTHER ADVICE OR SERVICE PROVIDED BY KVH IN CONNECTION WITH ANY PRODUCT.

KVH's liability in contract, tort or otherwise arising out of or in connection with any product shall not exceed the price paid for the product. IN NO EVENT SHALL KVH BE LIABLE FOR SPECIAL, PUNITIVE, INCIDENTAL, TORT OR CONSEQUENTIAL DAMAGES OR LOST PROFITS OR GOODWILL (INCLUDING ANY DAMAGES RESULTING FROM LOSS OF USE, DELAY IN DELIVERY OR OTHERWISE) ARISING OUT OF OR IN CONNECTION WITH THE PERFORMANCE OR USE OR POSSESSION OF ANY PRODUCT, OR ANY OTHER OBLIGATIONS RELATING TO THE PRODUCT, EVEN IF KVH HAS BEEN ADVISED OF THE POSSIBILITY OF SUCH DAMAGES.

If any implied warranty, including implied warranties of merchantability and fitness for a particular purpose, cannot be excluded under applicable law, then such implied warranty shall be limited in duration to ONE (1) YEAR from the date of the original retail purchase of this product by the original purchaser.

Some states/countries do not allow the exclusion or limitation of implied warranties or liability for incidental or consequential damages, so the above limitations may not apply to you. This warranty gives you specific legal rights, and you may also have other rights which vary from state/country to state/country.



KVH Industries, Inc.

50 Enterprise Center Middletown, RI 02842 U.S.A.
Phone: (401) 847-3327 Fax: (401) 849-0045
E-Mail: info@kvh.com Internet: <http://www.kvh.com>

KVH Europe A/S

Ved Klaedebo 12 2970 Hoersholm Denmark
Phone: +45 45 160 180 Fax: +45 45 867 077
E-Mail: info@kvh.dk Internet: <http://www.kvh.com>