

A Guide to TracVision SA owner's manual

- Installation Instructions
- User's Guide
- Technical Manual





TracVision SA Owner's Manual Addendum

(ECO #s 5616, 5846)

The following information applies to Revision D of the TracVision SA Owner's Manual (KVH Part Number 54-0149).

Your TracVision SA antenna has been upgraded! Instead of a single-output Low Noise Block (LNB), your system is now equipped with a dual-output LNB, giving you the ability to connect more than one IRD and TV to the system.

In addition, the baseplate connectors of your TracVision SA have been changed to make installation easier.

The following changes have been made to the Owner's Manual to reflect these system improvements:

1.2 TracVision SA System Overview

Figure 1-1 shows the new baseplate connectors and cable routing.

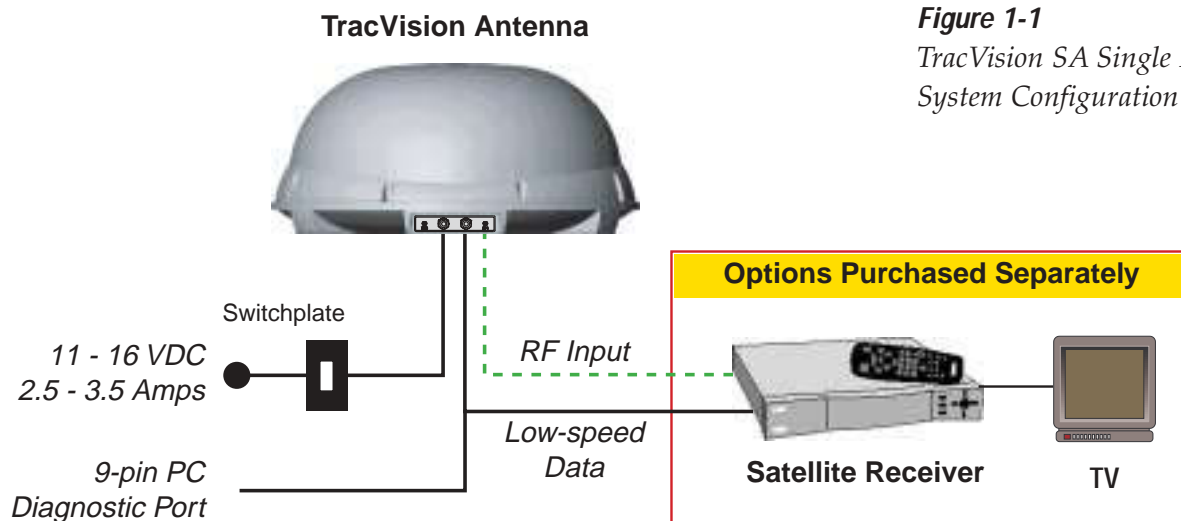

Figure 1-1
TracVision SA Single IRD System Configuration

Since the dual-output LNB is now standard, the following sidebar note no longer applies:



TracVision SA is equipped with a single-port Low Noise Block (LNB) that can provide signals to a single IRD. Should you wish to equip your vehicle with multiple TVs and IRDs, a dual-port LNB is available as an option (KVH Part Number 19-0056).

1.2.1 TracVision SA Components

The Antenna Unit includes the antenna positioning mechanism, signal front end, power supply and control elements. These include antenna drive controls and mechanisms, the cable wrap subassembly, power conditioning and regulating circuits, and the RF detector. The antenna is a parabolic dish mounting a **dual-output** low noise block (LNB) converter with built-in preamplifier. A molded ABS radome encloses the baseplate and is secured in place with standard fasteners. Liquid-tight (watertight) fittings located on the back of the baseplate join the power, signal, and control cabling from units inside the vehicle.

2.4 Connecting the Antenna Unit

TracVision SA Cable Ports

In a dual-output LNB configuration, cable port #1 can be used to connect a second RF cable (when connecting multiple IRDs and TVs to the system).

Figure 2-14 shows the antenna unit's exterior baseplate cable ports, consisting of two RF connectors (ports #1 and #4) and two liquid-tight fittings (ports #2 and #3). Figure 2-15 shows the interior baseplate wiring. Refer to these figures when connecting cables to the antenna unit.

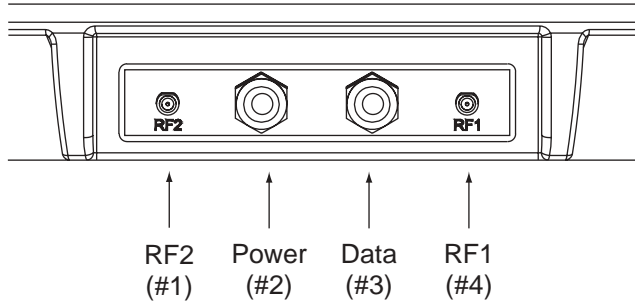

Figure 2-14
Cable Port Assignments
(Exterior of Baseplate)

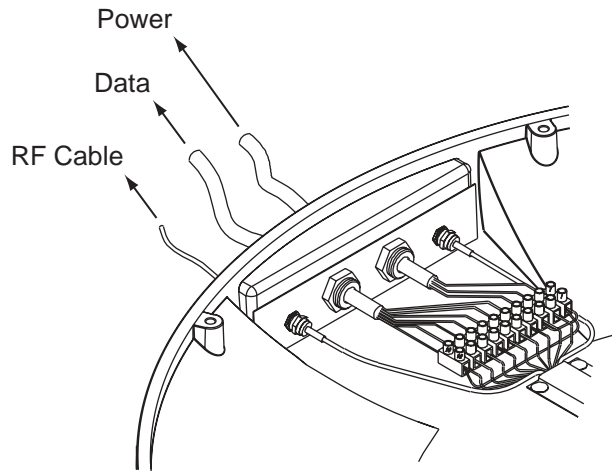

Figure 2-15
Interior Baseplate Wiring

2.4.1 Connecting the Antenna Data Cable to the IRD

The data cable now enters the baseplate through the second liquid-tight fitting (cable port #3). Interior baseplate wiring is unchanged.

TracVision SA Data Cable Wiring Process

1. Feed the cable up to the roof and through the second liquid-tight fitting (#3) as pictured in Figure 2-14.

2.4.2 Connecting the Antenna to Vehicle Power

The power cable now enters the baseplate through the first liquid-tight fitting (cable port #2). Interior baseplate wiring is unchanged.

Connecting to Vehicle Power

TracVision SA must be connected to a +12 volt DC, 2.5-3.5 amp power supply to operate. The supplied power cable should be run up to the antenna unit, through the first liquid-tight fitting (#2) as pictured in Figure 2-14, and wired to the terminal connector strip as illustrated in Figure 2-20.

2.4.4 Connecting the Antenna RF Signal Cable to the IRD



When shipped from the factory, the antenna's RF connectors are protected with caps. Leave the cap installed on the RF2 connector unless you are going to connect a second RF cable to the TracVision SA.

You no longer need to insert RF cables into the baseplate; they now simply connect to the exterior baseplate connectors.

The RF signal cable is fitted with an F-type connector at only one end and should be attached to TracVision SA and the IRD as follows:

1. For a single IRD installation, connect the F-connector end of the RF signal cable to the Antenna Unit baseplate connector labeled RF1 (see Figure 2-14). Once the cable is securely connected, loosen the sealing nut at the base of the RF1 connector and tighten it onto the end of the RF cable.
2. Feed the bare end of the RF signal cable through the cable access hole and into the vehicle.
3. Attach the provided F-connector to the end of the RF signal cable inside the vehicle as illustrated in Figure 2-23a-d, using an Augat Snap 'n Seal Crimp/Strip tool to lock the connector on the cable.
 - A. Slide compression fitting onto raw cable before beginning connector termination.

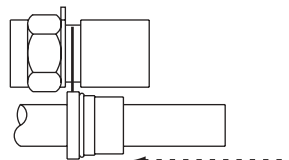
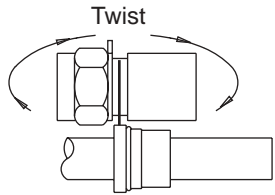

Figure 2-23a-d
Attaching the KVH-provided
F-connector to an RF Cable

- B. Twist and break off connector body.



KVH has provided an F-connector for use with the TracVision SA. This connector specifically requires the Augat Snap 'n Seal Crimp/Strip Tool, part number IT1000.

- C. Use Augat tool to strip center conductor and trim back overall jacket. Do not cut through braid.

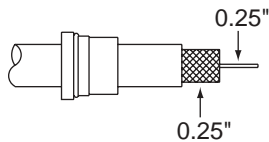

If you do not have this tool, you will need to purchase a silicone-filled, weatherproof F-connector (Radio Shack Part Number 278-236 or equivalent) to use instead.

- D. Slide connector body onto the prepared cable. Slide the compression fitting up into the connector body. Use Augat tool to snap on the connector.

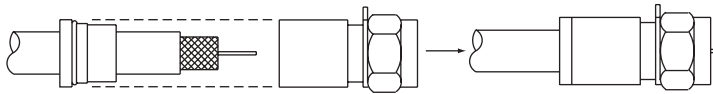

4. Attach the cable to the IRD connector labeled SATELLITE IN.

The following two sections have been added to explain how to connect multiple IRDs and TVs to the TracVision SA.

Installing Two IRDs and TVs

To connect a second TV and IRD to the TracVision SA system, you must connect a second RF cable to the Antenna Unit baseplate connector labeled RF2. The other end of the RF cable should be run down into the vehicle and connected directly to the second IRD. The data cable remains connected to the first (master) IRD. Each IRD/TV pair can operate independently of the other, allowing different viewers to watch different channels. However, the master IRD must remain turned on if the second IRD is in use.



KVH recommends the use of RG-6 or RG-11 (75 ohms) cable for RF wiring. Use of non-RG-6 or RG-11 (75 ohms) cables will result in degraded performance. The KVH warranty does not cover degraded performance due to improper wiring.

Connecting Three or More IRDs and TVs

To install three or more IRD/TV pairs, an active multiswitch (Channel Master model 6214IFD or equivalent) is placed between the Antenna Unit and the IRDs. Figure 2-24 illustrates typical wiring arrangements for multiple IRDs. If more than four IRDs are required, contact KVH for additional wiring instructions. Mount the multiswitch unit in accordance with the manufacturer's instruction sheet.

Figure 2-24
*Installing Three or More IRDs
Using an Active Multiswitch*



The data cable should be attached to the master IRD. The master IRD must remain on for the secondary IRDs to function properly.

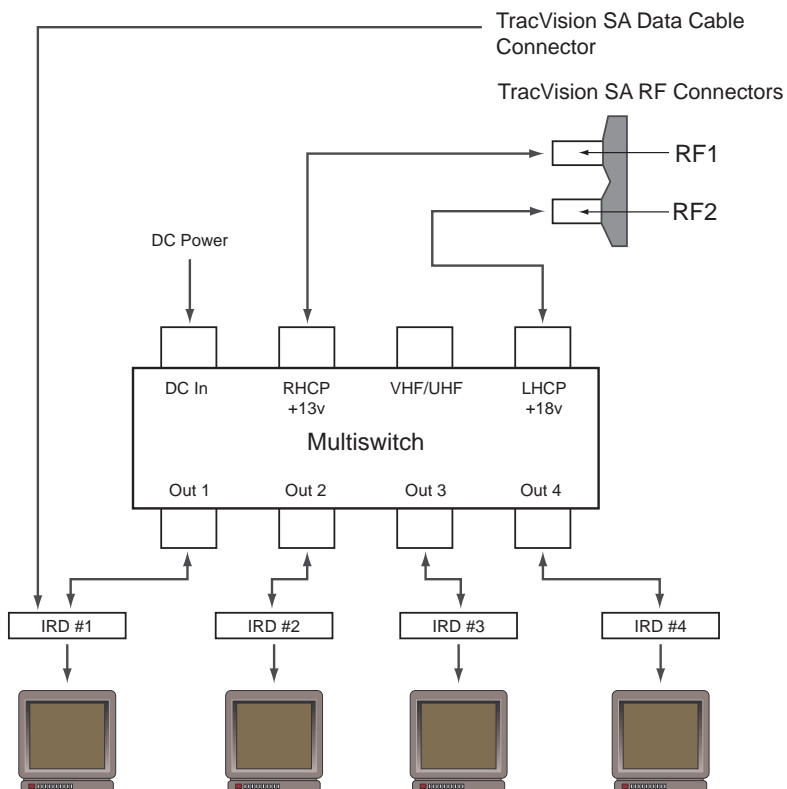

1. Connect the RF cable tagged "RF1" to the multiswitch input labeled "LNB RHCP +13V".
2. Connect a second RF cable to the multiswitch input labeled "LNB LHCP +18V".
3. Connect the multiswitch outputs to individual IRD inputs. Use RG-6 cable terminated with F-type connectors for all RF connections.
4. Terminate all unused output connectors with 75 ohm DC blocks (Channel Master #7184, Radio Shack #15-1259 or equivalent).

5.3 Replaceable Parts

Table 5-1 has been updated to include the dual-output LNB.

Part Name	Part Number
Radome Assembly	02-0953-02
Baseplate Assembly	02-0952-02
Power Cable	32-0590-30
Data Cable	32-0591-30
RF Cable	32-0589-30
EchoStar Adapter Unit *	02-0899
CPU PCB	02-1144-01
System Fuse	16-0017-3150
LNB	19-0056

Table 5-1
Field Replaceable Units

* Optional, purchased separately

Appendix A

System Specifications

Table A-1 has been updated to include the dual-output LNB.

Table A-1
TracVision SA System
Specifications

Physical Characteristics

Power	11-16 volts DC @ 2.5 amps nominal, 3.5 amps peak
Dimensions/Weight	32" (81 cm) wide x 14.8" (38 cm) high, 33 lbs (15 kg)
LNB	Dual Output
Maintenance Port	9600 bps, 8,N,1,EIA, RS232

Pointing System

Elevation Range	15° to 75°
Azimuth Range	720°
Position Repeatability	0.1°

Environmental

Operating Temperature	-25°C to +55°C
Storage Temperature	-40°C to +85°C
Humidity	to 100 percent

Appendix B

Functional Block Diagram

The functional block diagram has been updated to include a second RF cable.

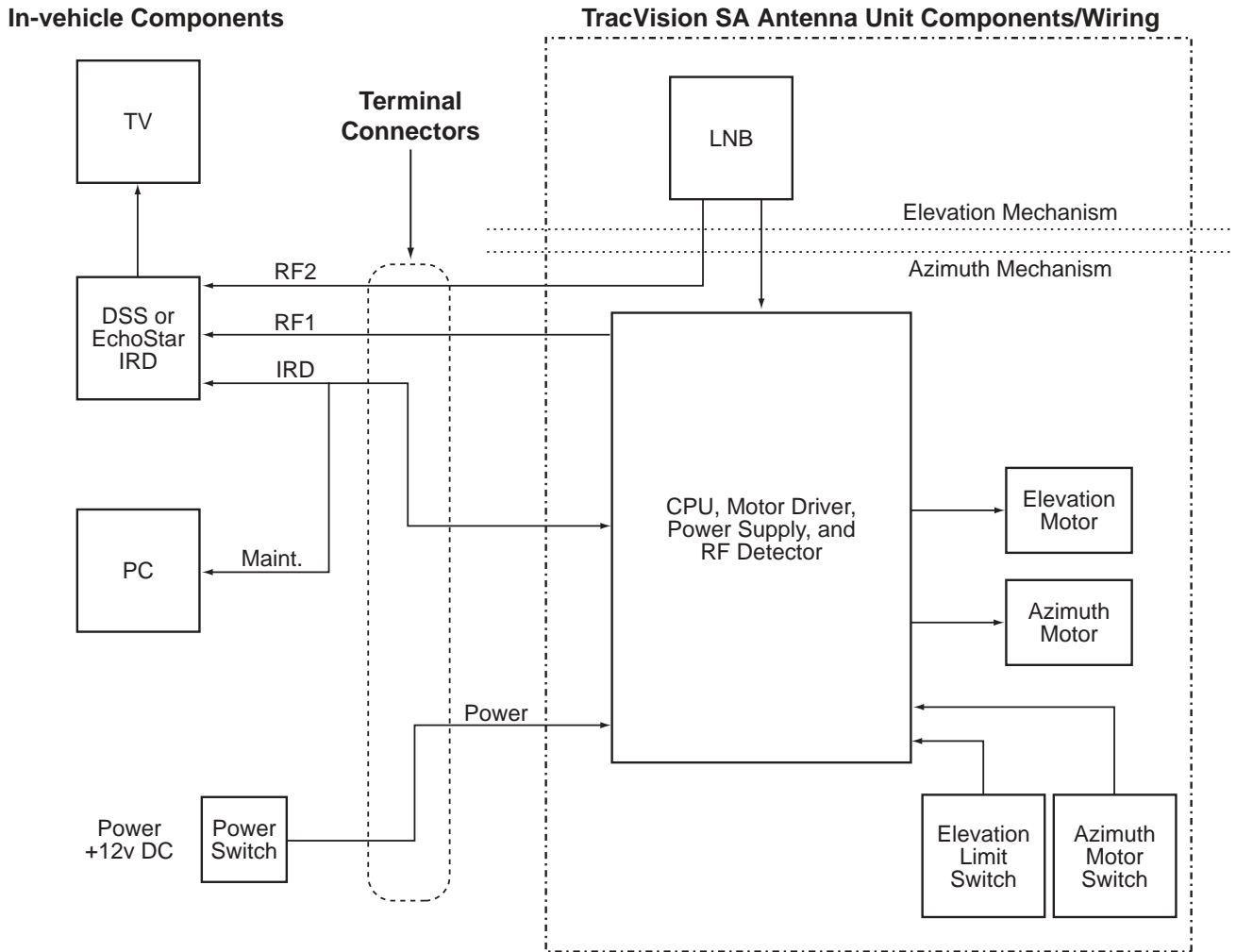

Cable Assignments

- RF1.....RF Cable (32-0589-30)
- RF2.....Owner-provided RG-6 or RG-11 (75 ohms) cable
- IRD/Maint.....Data Cable (32-059-30)
- Power.....Power Cable (32-0590-30)

TracVision SA Owner's Manual Addendum



(ECO #5616)

The following information applies to Revision D of the TracVision SA Owner's Manual (KVH Part Number 54-0149).

Your TracVision SA antenna has been upgraded! Instead of a single-output Low Noise Block (LNB), your system is now equipped with a dual-output LNB, giving you the ability to connect more than one IRD and TV to the system.

Since the TracVision SA Owner's Manual assumes a single-output LNB configuration, the following changes have been made to reflect a dual-output LNB configuration:

1.2 TracVision SA System Overview

Since the dual-output LNB is now standard, the following sidebar note no longer applies:



TracVision SA is equipped with a single-port Low Noise Block (LNB) that can provide signals to a single IRD. Should you wish to equip your vehicle with multiple TVs and IRDs, a dual-port LNB is available as an option (KVH Part Number 19-0056).

1.2.1 TracVision SA Components

The Antenna Unit includes the antenna positioning mechanism, signal front end, power supply and control elements. These include antenna drive controls and mechanisms, the cable wrap subassembly, power conditioning and regulating circuits, and the RF detector. The antenna is a parabolic dish mounting a **dual-output** low noise block (LNB) converter with built-in

preamplifier. A molded ABS radome encloses the baseplate and is secured in place with standard fasteners. Liquid-tight (watertight) fittings located on the back of the baseplate join the power, signal, and control cabling from units inside the vehicle.

2.4 Connecting the Antenna Unit

TracVision SA Cable Ports

Figure 2-14 has been changed to remove the “Not Used” label from cable port #1. In a dual-output LNB configuration, this cable port can be used to connect a second RF cable (when connecting multiple IRDs and TVs to the system).

Figure 2-14
Cable Port Assignments
(Exterior of Baseplate)

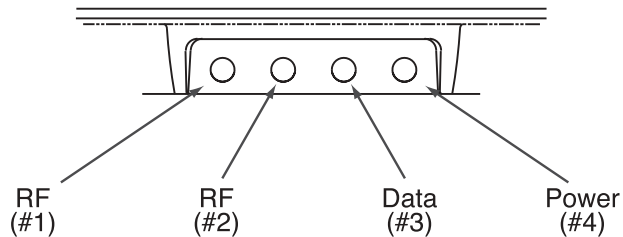

2.4.4 Connecting the Antenna RF Signal Cable to the IRD

The following sidebar note has been changed to remove the reference to installing a dual-output LNB:



When shipped from the factory, the #1 liquid-tight fitting is sealed with a rubber stopper. Leave the stopper in the fitting **unless you are going to connect a second RF cable to the TracVision SA.**

The following two sections have been added to explain how to connect multiple IRDs and TVs to the TracVision SA.

Installing Two IRDs and TVs

To connect a second TV and IRD to the TracVision SA system, you must connect a second RF cable to the RF2 connector within the Antenna Unit baseplate. The other end of the RF cable should be run down into the vehicle and connected directly to the second IRD. The data cable remains connected to the first (master) IRD. Each IRD/TV pair can operate independently of the other, allowing different viewers to watch different channels. However, the master IRD must remain turned on if the second IRD is in use.



KVH recommends the use of RG-6 or RG-11 (75 ohms) cable for RF wiring. Use of non-RG-6 or RG-11 (75 ohms) cables will result in degraded performance. The KVH warranty does not cover degraded performance due to improper wiring.

Connecting Three or More IRDs and TVs

To install three or more IRD/TV pairs, an active multiswitch (Channel Master model 6214IFD or equivalent) is placed between the Antenna Unit and the IRDs. Figure 2-24 illustrates typical wiring arrangements for multiple IRDs. If more than four IRDs are required, contact KVH for additional wiring instructions. Mount the multiswitch unit in accordance with the manufacturer's instruction sheet.

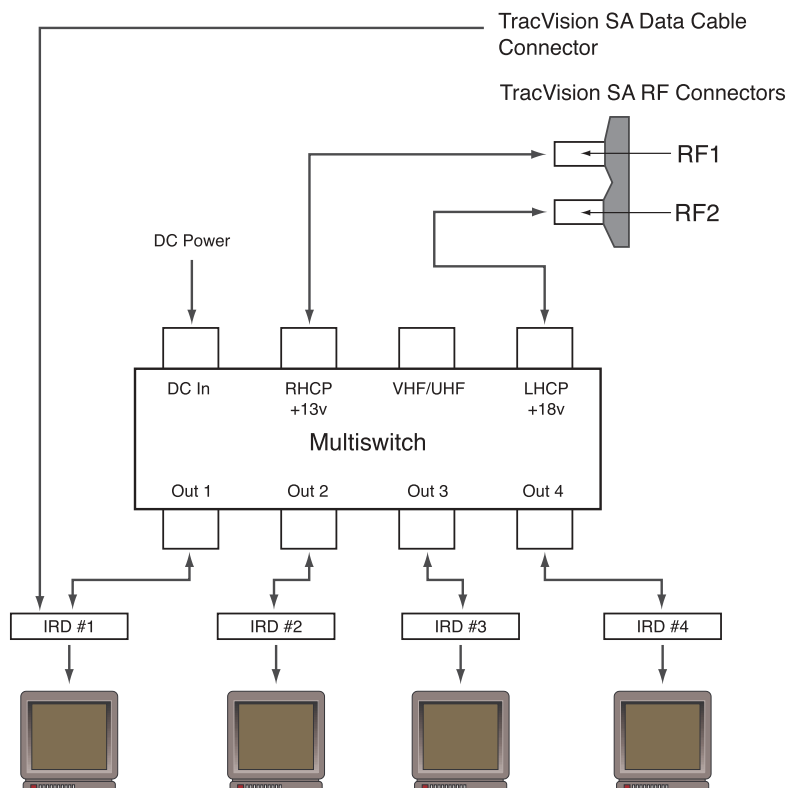

Figure 2-24

Installing Three or More IRDs Using an Active Multiswitch



The data cable should be attached to the master IRD. The master IRD must remain on for the secondary IRDs to function properly.

1. Connect the RF cable tagged "RF1" to the multiswitch input labeled "LNB RHCP +13V".
2. Connect a second RF cable to the multiswitch input labeled "LNB LHCP +18V".
3. Connect the multiswitch outputs to individual IRD inputs. Use RG-6 cable terminated with F-type connectors for all RF connections.
4. Terminate all unused output connectors with 75 ohm DC blocks (Channel Master #7184, Radio Shack #15-1259 or equivalent).

5.3 Replaceable Parts

Table 5-1 has been updated to include the dual-output LNB.

Table 5-1
Field Replaceable Units

Part Name	Part Number
Radome Assembly	02-0953-02
Baseplate Assembly	02-0952-02
Power Cable	32-0590-30
Data Cable	32-0591-30
RF Cable	32-0589-30
EchoStar Adapter Unit *	02-0899
CPU PCB	02-1144-01
System Fuse	16-0017-3150
LNB	19-0056

* Optional, purchased separately

Appendix A

System Specifications

Table A-1 has been updated to include the dual-output LNB.

Physical Characteristics

Power	11-16 volts DC @ 2.5 amps nominal, 3.5 amps peak
Dimensions/Weight	32" (81 cm) wide x 14.8" (38 cm) high, 33 lbs (15 kg)
LNB	Dual Output
Maintenance Port	9600 bps, 8,N,1,EIA, RS232

Pointing System

Elevation Range	15° to 75°
Azimuth Range	720°
Position Repeatability	0.1°

Environmental

Operating Temperature	-25°C to +55°C
Storage Temperature	-40°C to +85°C
Humidity	to 100 percent

Table A-1

TracVision SA System Specifications

Appendix B

Functional Block Diagram

The functional block diagram has been updated to include a second RF cable.

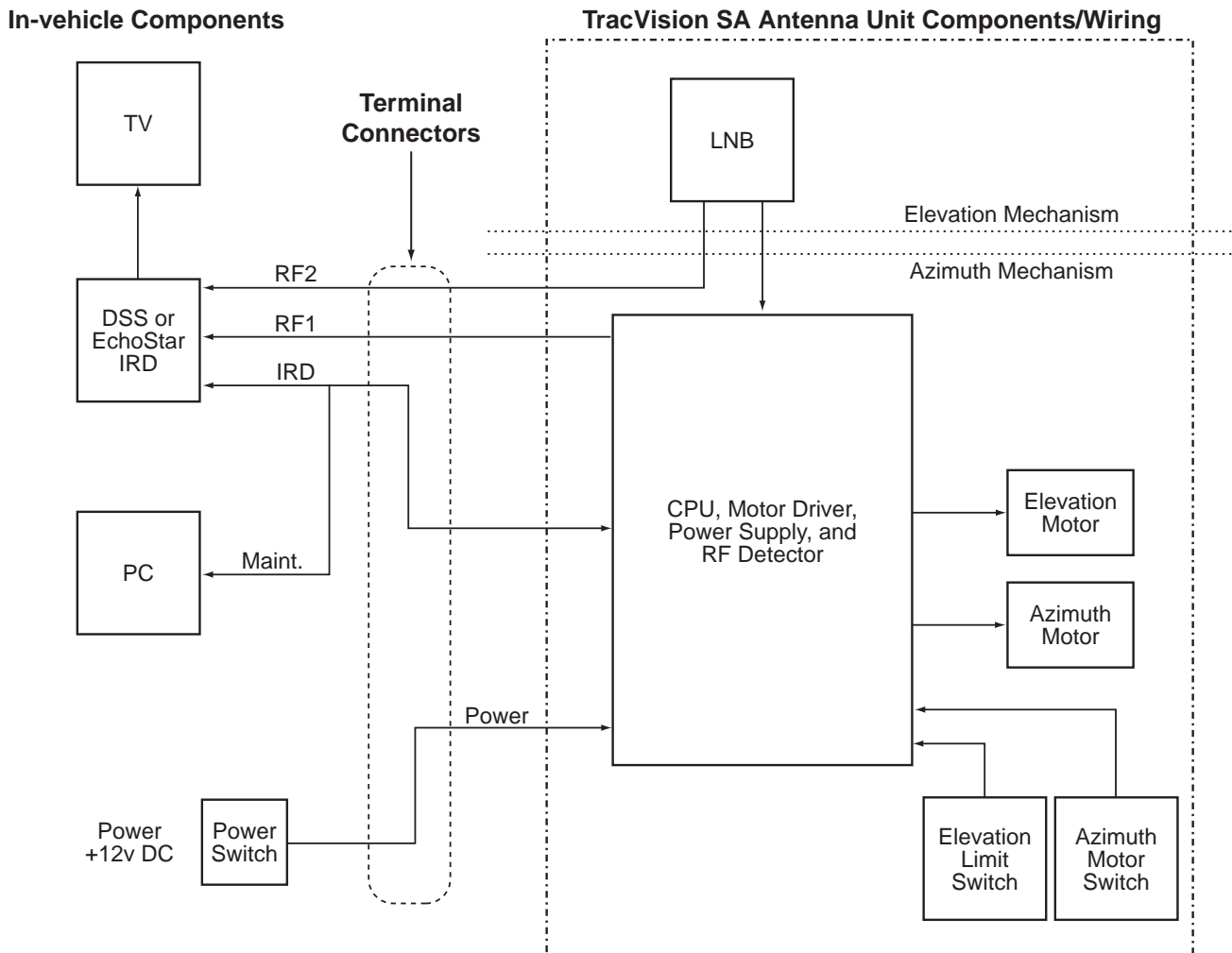

Cable Assignments

- RF1.....RF Cable (32-0589-30)
- RF2.....Owner-provided RG-6 or RG-11 (75 ohms) cable
- IRD/Maint.....Data Cable (32-059-30)
- Power.....Power Cable (32-0590-30)

TracVision SA Owner's Manual Addendum



(ECO #s 5382, 5410, 5426)

The following information applies to Revision D of the TracVision SA Owner's Manual (KVH Part Number 54-0149).

5.3 Replaceable Parts

Minor changes have been made to simplify the TracVision SA printed circuit board (PCB). Table 5-1 has been updated to include the new part numbers for the PCB and associated fuse. In addition, Figures 5-1 and 5-5 (previously 5-4) have been changed to illustrate the new PCB.

Part Name	Part Number
Radome Assembly	02-0953-02
Baseplate Assembly	02-0952-02
Power Cable	32-0590-30
Data Cable	32-0591-30
RF Cable	32-0589-30
EchoStar Adapter Unit *	02-0899
CPU PCB	02-1144-01
System Fuse	16-0017-3150
LNB	19-0194

* Optional, purchased separately

Table 5-1

Field Replaceable Units



*Should the fuse ever need to be replaced, TracVision SA uses a 5x20 mm, **3.15-amp**, 250-volt fast-blow fuse.*

5.4 Field Replaceable Unit Procedures

The elevation axis motor shaft bracket has been redesigned for simplicity, allowing easier access to the PCB. This new configuration requires minor changes to the procedure for removing and replacing the PCB.

Figure 5-1
Antenna, PCB, and Rotating Plate

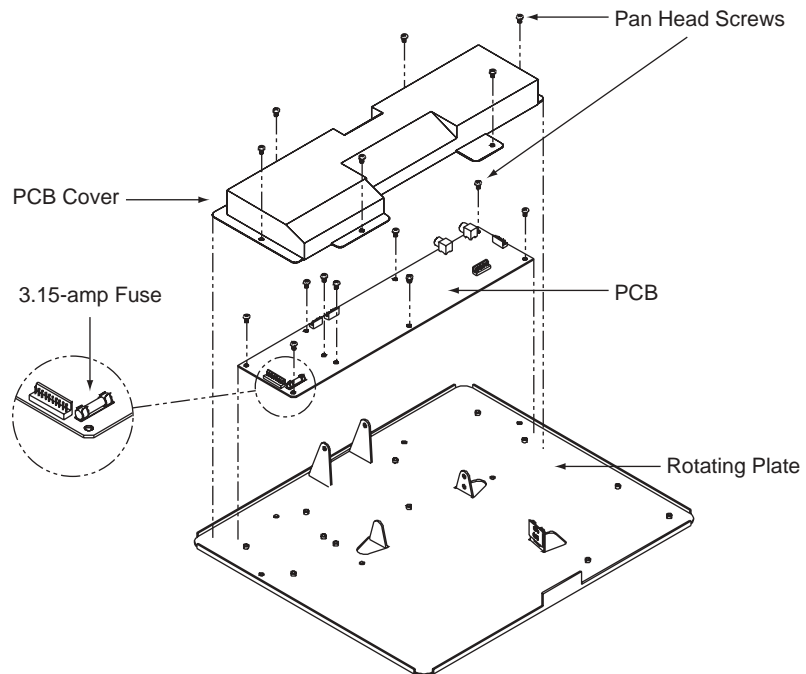
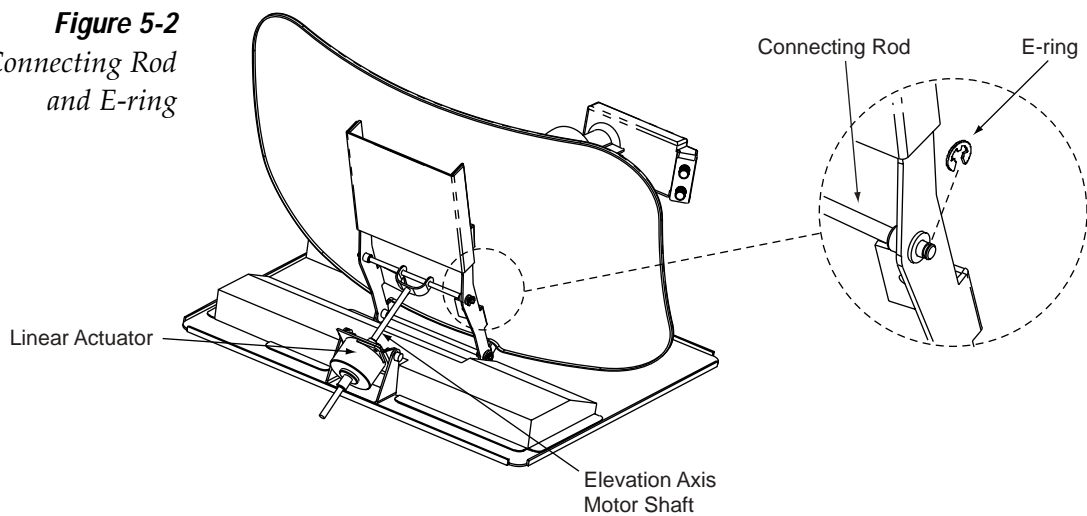

Figure 5-2
Close-up of Connecting Rod and E-ring



5.4.1 PCB Removal and Replacement

Estimated Time to Repair: ½ hour

The microprocessor PCB assembly is protected by a cover fastened to the rotating plate – Fig. 5-1. The cover must be removed to gain access to the main power fuse and the PCB assembly.

1. Using needle-nose pliers, remove the E-ring from one end of the connecting rod – Fig. 5-2.



When carrying out maintenance on the PCB, be sure to not drop any of the small screws inside the mechanism. If a screw is lost within the baseplate, it must be retrieved to avoid causing any damage when the unit rotates.

2. Remove the connecting rod by sliding it off the bracket.
3. Fully retract the elevation axis motor shaft – Fig. 5-4.

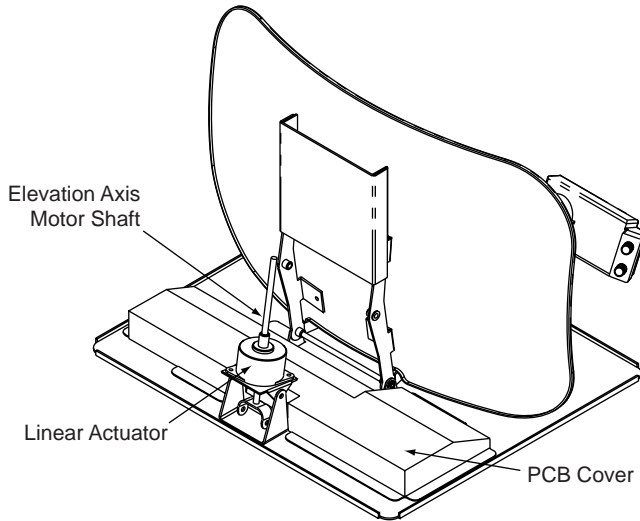

Figure 5-4
Removing the PCB Cover

4. Remove 6 pan head screws from the PCB cover flanges.
5. Remove the PCB cover. To get the necessary clearance, rotate the linear actuator up 90° while lifting the PCB cover – Fig. 5-4.
6. Remove cable connectors from PCB. Figure 5-5 illustrates the PCB arrangement and connector locations.



TracVision SA is equipped with a 5x20 mm, **3.15-amp**, 250-volt fast-blow fuse, which is mounted on the PCB. To access and replace the fuse, remove the PCB cover.

Figure 5-5
PCB Connector Locations – Rear View

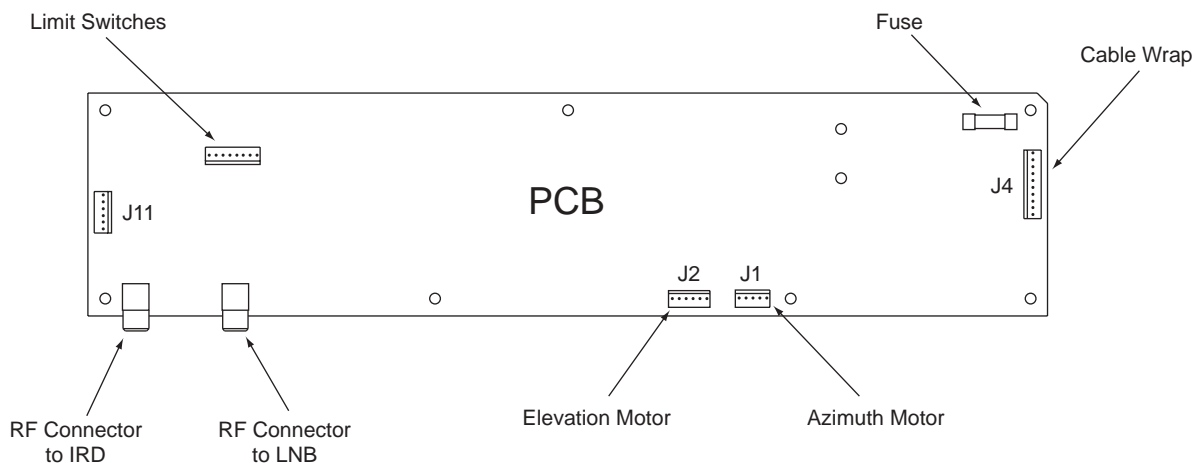



When replacing the PCB cover, be careful not to pinch any cables.

7. The PCB is mounted to the rotating plate with 9 pan head screws.
8. Reverse this process to install the replacement PCB. Reinstall all cable connectors removed in Step 6.
9. Carry out the LNB calibration procedure (*Section 5.4.2*).

TracVision SA Owner's Manual Addendum



(ECO #s 5382, 5426)

The following information applies to Revision D of the TracVision SA Owner's Manual (KVH Part Number 54-0149).

5.3 Replaceable Parts

Due to system improvements, the TracVision SA now consumes less power. As a result, the system fuse has been changed from a 4-amp to a 3.15-amp fuse.

Part Name	Part Number
Radome Assembly	02-0953-02
Baseplate Assembly	02-0952-02
Power Cable	32-0590-30
Data Cable	32-0591-30
RF Cable	32-0589-30
EchoStar Adapter Unit *	02-0899
CPU PCB	02-1043-01
System Fuse	16-0017-3150
LNB	19-0194

* Optional, purchased separately

Table 5-1

Field Replaceable Units



*Should the fuse ever need to be replaced, TracVision SA uses a 5x20 mm, **3.15-amp**, 250-volt fast-blow fuse.*

5.4 Field Replaceable Unit Procedures

The elevation axis motor shaft bracket has been redesigned for simplicity, allowing easier access to the printed circuit board (PCB). This new configuration requires minor changes to the procedure for removing and replacing the PCB.

Figure 5-2
Close-up of Connecting Rod
and E-ring



5.4.1 PCB Removal and Replacement

Estimated Time to Repair: ½ hour



When carrying out maintenance on the PCB, be sure to not drop any of the small screws inside the mechanism. If a screw is lost within the baseplate, it must be retrieved to avoid causing any damage when the unit rotates.

The microprocessor PCB assembly is protected by a cover fastened to the rotating plate – Fig. 5-1. The cover must be removed to gain access to the main power fuse and the PCB assembly.

1. Using needle-nose pliers, remove the E-ring from one end of the connecting rod – Fig. 5-2.
2. Remove the connecting rod by sliding it off the bracket.
3. Fully retract the elevation axis motor shaft – Fig. 5-4.

Figure 5-4
Removing the PCB Cover

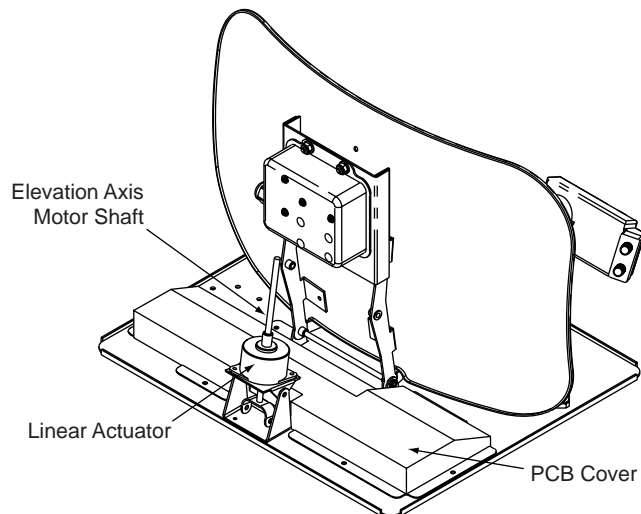

4. Remove 6 pan head screws from the PCB cover flanges.
5. Remove the PCB cover. To get the necessary clearance, rotate the linear actuator up 90° while lifting the PCB cover – Fig. 5-4.
6. Remove cable connectors from PCB. Figure 5-5 illustrates the PCB arrangement and connector locations.



TracVision SA is equipped with a 5x20 mm, **3.15-amp**, 250-volt fast-blow fuse, which is mounted on the PCB. To access and replace the fuse, remove the PCB cover.

Figure 5-5

PCB Connector Locations – Rear View

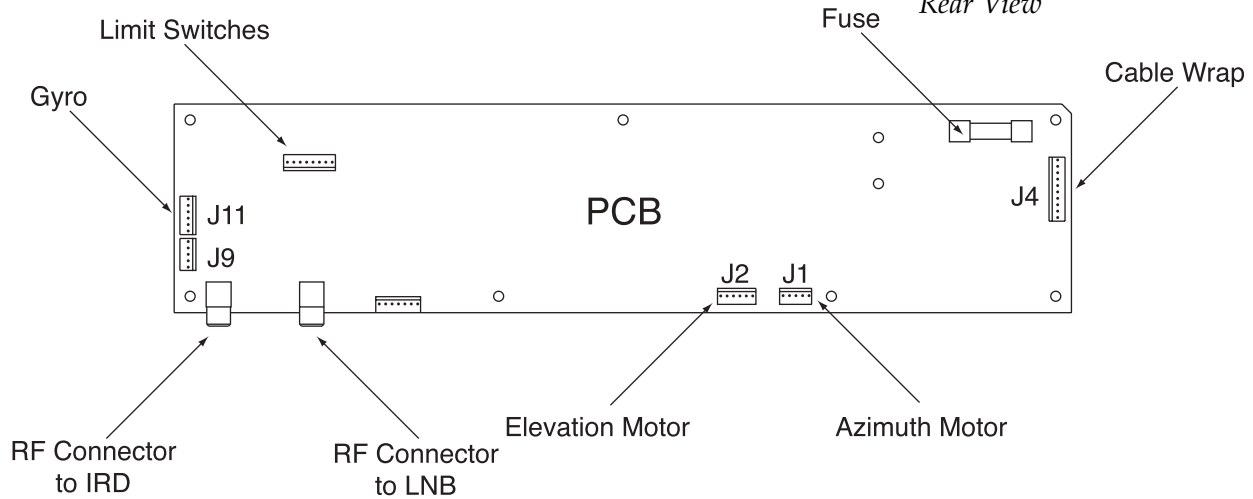

7. The PCB is mounted to the rotating plate with 9 pan head screws.
8. Reverse this process to install the replacement PCB. Reinstall all cable connectors removed in Step 6.
9. Carry out the LNB calibration procedure (Section 5.4.2).



When replacing the PCB cover, be careful not to pinch any cables.

TracVision SA Owner's Manual Addendum



(ECO #5426)

The following information applies to Revision D of the TracVision SA Owner's Manual (KVH Part Number 54-0149).

5.3 Replaceable Parts

Due to system improvements, the TracVision SA now consumes less power. As a result, the system fuse has been changed from a 4-amp to a 3.15-amp fuse.

Part Name	Part Number
Radome Assembly	02-0953-02
Baseplate Assembly	02-0952-02
Power Cable	32-0590-30
Data Cable	32-0591-30
RF Cable	32-0589-30
EchoStar Adapter Unit *	02-0899
CPU PCB	02-1043-01
System Fuse	16-0017-3150
LNB	19-0194

* Optional, purchased separately

Table 5-1

Field Replaceable Units



Should the fuse ever need to be replaced, TracVision SA uses a 5x20 mm, **3.15-amp**, 250-volt fast-blow fuse.

5.4.1 PCB Removal and Replacement

The sidebar note has been changed to indicate the new rating of the fuse.



TracVision SA is equipped with a 5x20 mm, **3.15-amp**, 250-volt fast-blow fuse, which is mounted on the PCB. To access and replace the fuse, remove the PCB cover.

Congratulations!

You have selected one of the most advanced land-mobile satellite tracking systems available today. KVH® Industries' TracVision® SA is designed for use with DIRECTV® and the DISH™ Network. This manual provides detailed instructions on the proper installation, use, and maintenance of your TracVision SA system.

Throughout this manual, important information is marked for your attention by these icons:



A helpful tip that either directs you to a related area within the manual or offers suggestions on getting the highest quality out of your system.



An alert to important information regarding procedures, product specifications, or product use.



Information about installation, maintenance, troubleshooting, or other mechanical issues.



An electrical safety warning to help identify electrical issues that can be a hazard to either this KVH product or a user.



TracVision SA Serial Number



This serial number will be required for all troubleshooting or service calls made regarding this product.

Direct questions, comments, or suggestions to:

KVH Industries, Inc.

50 Enterprise Center
Middletown, RI 02842 USA
Tel: +1 401 847-3327
Fax: +1 401 849-0045
E-mail: info@kvh.com
Internet: www.kvh.com

Click here to go to our state-of-the-art Customer Support web page – the fastest and easiest way to get all of your questions answered!



The Quality Advantage



KVH Part # 54-0149 Rev. D
© 2001, KVH Industries, Inc.

TracVision® and KVH® are registered trademarks of
KVH Industries, Inc.

DIRECTV® is an official trademark of DIRECTV,
a unit of GM Hughes Electronics Corporation.

DISH™ Network is an official trademark of
EchoStar Communications Corporation.

Table of Contents

- 1 Introduction 1-1**
- 1.1 Digital Satellite Television 1-1**
- 1.2 TracVision SA System Overview 1-1**
 - 1.2.1 TracVision SA Components.....1-2
 - 1.2.2 Integrated Receiver Decoder.....1-2
- 1.3 Materials Provided with TracVision SA 1-3**
 - 1.3.1 Additional Materials Required for TracVision SA Use1-3

- 2 Installation 2-1**
- 2.1 Overview of Installation 2-1**
 - 2.1.1 Installation Tools and Materials Required.....2-1
 - 2.1.2 Kitpack.....2-2
- 2.2 Choosing the Best Location 2-2**
- 2.3 Mounting the Antenna Unit 2-3**
- 2.4 Connecting the Antenna Unit 2-7**
 - 2.4.1 Connecting the Antenna Data Cable to the IRD2-9
 - 2.4.2 Connecting the Antenna to Vehicle Power2-11
 - 2.4.3 Connecting the IRD Ground Wire.....2-12
 - 2.4.4 Connecting the Antenna RF Signal Cable to the IRD.....2-12
- 2.5 Checking Out the System 2-14**
- 2.6 Completing the Installation Process 2-15**
- 2.7 Configuring TracVision SA for Remote Satellite Dish Operation 2-16**

- 3 Operation 3-1**

- 4 Troubleshooting 4-1**
- 4.1 Causes and Remedies for Common Operational Issues 4-1**
 - 4.1.1 Blown Fuse or No Power.....4-2
 - 4.1.2 Dew or Rain Pooling on Dome4-2
 - 4.1.3 Satellite Signal Blocked.....4-2

4.1.4	Outside Satellite Coverage Zone.....	4-3
4.1.5	Incorrect or Loose RF Connectors	4-3
4.2	IRD Troubleshooting	4-3
4.2.1	IRD Data Port or Cable/Wiring	4-3
4.2.2	AC Power Fluctuating	4-3
4.2.3	EchoStar IRD Commissioning Check.....	4-4
4.2.4	Failed IRD Status Check	4-4
4.2.5	IRD Faulty.....	4-5
4.3	LNB Faults	4-5
4.4	Computer Diagnostics	4-5
4.5	Maintenance Port Parser Commands	4-6
5	Maintenance	5-1
5.1	Warranty/Service Information	5-1
5.2	Preventive Maintenance	5-1
5.3	Replaceable Parts	5-2
5.4	Field Replaceable Unit Procedures	5-3
5.4.1	PCB Removal and Replacement.....	5-5
5.4.2	Antenna LNB Replacement.....	5-5
5.4.3	EchoStar Adapter Replacement.....	5-7
5.5	Preparation for Shipment	5-7
Appendix A	System Specifications	A-1
Appendix B	Functional Block Diagram	B-1
Appendix C	Data Cable Wiring	C-1
C.1	Wiring TracVision SA to a 15-pin Data Connector	C-1
C.2	DB9 Data Connector Pin Assignments	C-2
Appendix D	EchoStar IRD Commissioning Procedure	D-1
Appendix E	Startup Data Sequence	E-1

Appendix F	Maintenance Port Parser Commands	F-1
F.1	System Commands	F-1
F.2	Manual Positioning Commands	F-2
F.3	Operational Commands	F-3
F.4	Target and Signal Commands	F-4

List of Figures

Figure 1-1	TracVision SA System Configuration	1-1
Figure 1-2	Primary Components of the TracVision SA	1-2
Figure 2-1	Antenna Blockage	2-2
Figure 2-2	Proper Orientation of the Antenna Unit	2-3
Figure 2-3	Forward Shipping Restraint (Arranged for Shipping)	2-3
Figure 2-4	TracVision SA Shipping Restraints (Top View, Installed for Shipping)	2-4
Figure 2-5	Mounting the Unit on a Curved Surface	2-4
Figure 2-6	Mounting Plate Dimensions	2-5
Figure 2-7	Connectors Facing Rear of Vehicle – Factory-drilled Drain Hole Locations	2-5
Figure 2-8	Connectors Facing Front of Vehicle – Recommended Drain Hole Locations	2-6
Figure 2-9	Forward Shipping Restraint Storage	2-6
Figure 2-10	Rotating Plate Shipping Restraint Storage	2-6
Figure 2-11	TracVision SA Shipping Restraints (Storage Position)	2-7
Figure 2-12	Proper Wire-to-Terminal Connection	2-7
Figure 2-13	Moving the Antenna Reflector	2-8
Figure 2-14	Cable Port Assignments (Exterior of Baseplate)	2-8
Figure 2-15	Cable Overlap within the TracVision SA Baseplate	2-8
Figure 2-16	Proper Terminal Strip Wiring Arrangement – Data Cable	2-9
Figure 2-17	DB9 Connector	2-9
Figure 2-18	EchoStar Adapter Installation	2-10

Figure 2-19	Proper Wire-to-Terminal Connection	2-11
Figure 2-20	Proper Terminal Strip Wiring Arrangement – Power Cable	2-11
Figure 2-21	Wiring TracVision SA to Vehicle Power	2-12
Figure 2-22	Connecting the RF Cable to TracVision SA	2-13
Figure 2-23a-d	Attaching the KVH-provided F-connector to an RF Cable	2-13
Figure 2-24	Remote Dish Wiring Configuration	2-16
Figure 5-1	Antenna, PCB, and Rotating Plate	5-3
Figure 5-2	Close-up of Linear Actuator, Pivot Bracket, and Pin	5-3
Figure 5-3	Antenna Assembly	5-4
Figure 5-4	PCB Connector Locations – Rear View	5-5
Figure 5-5	Attaching the Shipping Restraints to the Antenna Baseplate	5-7
Figure 5-6	Securing the Forward Shipping Restraint	5-8
Figure 5-7	Repackaging the TracVision SA	5-8
Figure C-1	DB9 Male and Female Connector Arrangement	C-2

List of Tables

Table 1-1	TracVision SA Packing List	1-3
Table 2-1	Kitpack Contents	2-2
Table 2-2	TracVision SA Operational Messages	2-14
Table 2-3	DSS On-screen Messages	2-15
Table 3-1	TracVision SA Automated Procedures	3-1
Table 4-1	Troubleshooting Matrix	4-1
Table 5-1	Field Replaceable Units	5-2
Table A-1	TracVision SA System Specifications	A-1
Table C-1	Alternate Wiring Arrangement for TracVision SA Data Cable to DB15 (15-wire) Connector	C-1
Table C-2	DB9 Pin Functions and Color Code	C-2
Table F-1	System Commands	F-1
Table F-2	Manual Positioning Commands	F-2

Table F-3	Operational Commands	F-3
Table F-4	Target and Signal Commands	F-4

1 Introduction

1.1 Digital Satellite Television

The DIRECTV® and DISH™ Network systems transmit digital audio and video data from land-based transmitters to a satellite “parked” above the equator. Each satellite relays the signals in spot beams covering the continental United States and contiguous waters. TracVision SA automatically identifies, locks on to and receives signals from the appropriate satellite when your vehicle is stationary.



TracVision SA is a self-acquiring satellite TV antenna for use when your vehicle is stationary. The system is not designed to track the TV satellite when the vehicle is moving.

1.2 TracVision SA System Overview

A complete satellite TV system includes the TracVision SA connected to an Integrated Receiver Decoder (IRD), aka a “satellite receiver,” and a television set. A desktop or laptop computer is used to conduct diagnostics. The interrelationship of units is illustrated in Figure 1-1. System specifications and a functional block diagram are provided in *Appendices A and B*, respectively.



TracVision SA is equipped with a single-port Low Noise Block (LNB) that can provide signals to a single IRD. Should you wish to equip your vehicle with multiple TVs and IRDs, a dual-port LNB is available as an option (KVH Part Number 19-0056).

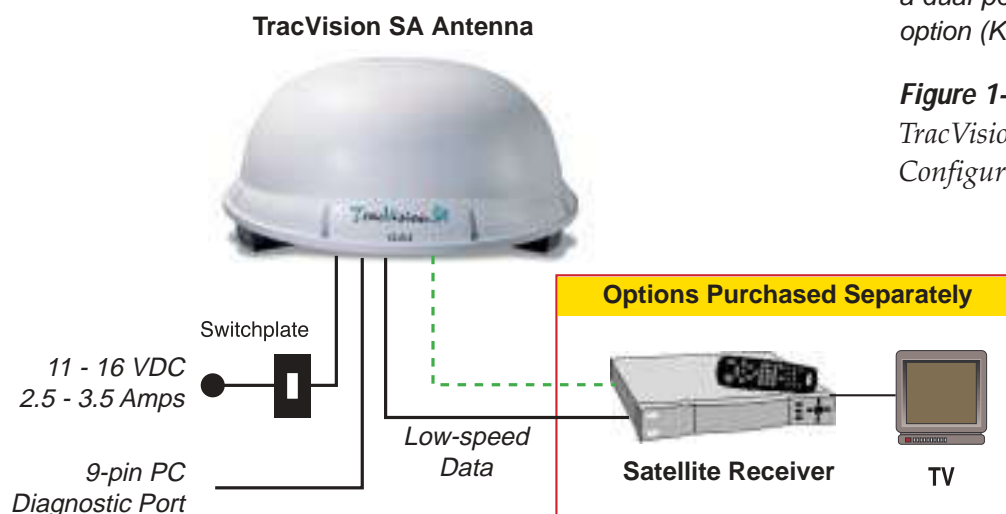

Figure 1-1
TracVision SA System Configuration

1.2.1 TracVision SA Components

The Antenna Unit includes the antenna positioning mechanism, signal front end, power supply and control elements. These include antenna drive controls and mechanisms, the cable wrap subassembly, power conditioning and regulating circuits, and the RF detector. The antenna is a parabolic dish mounting a single-port low noise block (LNB) converter with built-in preamplifier. A molded ABS radome encloses the baseplate and is secured in place with standard fasteners. Liquid-tight (watertight) fittings located on the back of the baseplate join the power, signal, and control cabling from units inside the vehicle.

Figure 1-2
Primary Components of the
TracVision SA



Always lift the antenna unit by the gray baseplate and not the radome, antenna reflector, or internal mechanical assemblies. **NEVER** pick up the unit by the LNB!

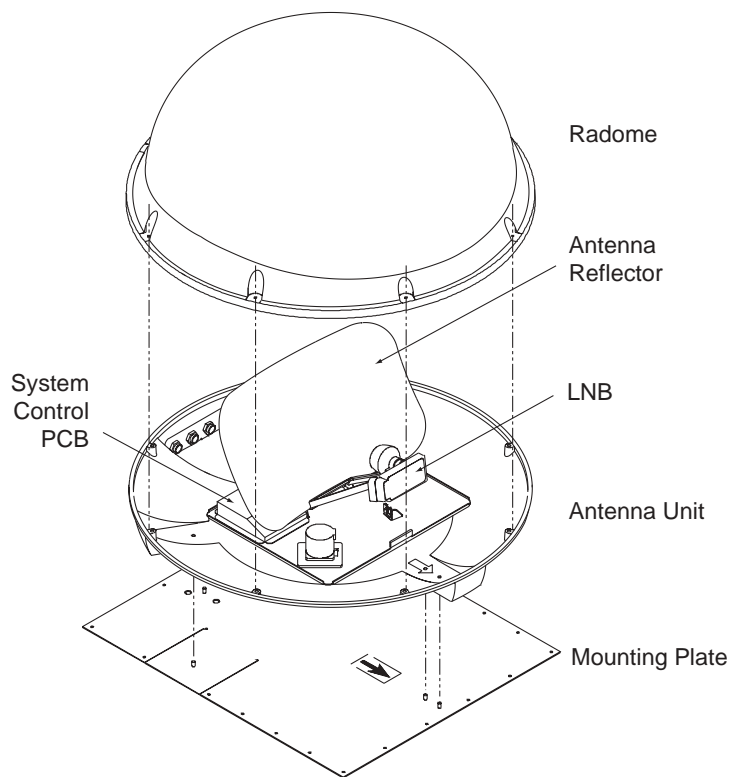

On-screen messages are not available with a DISH Network IRD.

1.2.2 Integrated Receiver Decoder

The IRD receives satellite signals from the Antenna Unit for signal decoding, processing and channel selection, and sends the signals to the TV set for viewing. Messages are sent from the IRD to the Antenna Unit and messages are received from the Antenna Unit for display on the television screen. The IRD also provides the interface for the user to activate authorization for reception. Please refer to the User's Manual provided with your selected IRD for complete operating instructions.

1.3 Materials Provided with TracVision SA

Table 1-1 lists the units, cables, and materials packed in the TracVision SA package by name and KVH part number.

Component	KVH Part No.
Antenna Unit (comprising):	01-0225-02
Baseplate Assembly	02-0952-02
Radome Assembly	02-0953-02
RF Cable (30 ft)	32-0589-30
Power Cable (30 ft)	32-0590-30
Data Cable (30 ft)	32-0591-30
IRD Ground Wire (50 ft)	32-0583-50
Mounting Plate	20-0668
Kitpack*	72-0094
Installation and Operation Manual	54-0149

* A complete listing of kitpack contents is provided in [Section 2.1.2, "Kitpack."](#)

Table 1-1

TracVision SA Packing List



Cables for the TracVision SA are stored beneath the antenna unit during shipping.

1.3.1 Additional Materials Required for TracVision SA Use

To make full use of your new TracVision SA and receive satellite TV on the road, you will need to provide/purchase the following:

- Television
- Appropriate IRD for your selected satellite TV service (if using the DISH Network, a Model 4000 or 5000 IRD will be required)
- Optional KVH EchoStar Adapter (for use with the DISH Network service and IRD)



Operation of the DISH Network requires the purchase of an EchoStar IRD Adapter. To purchase an EchoStar Adapter, contact KVH or your local KVH dealer and ask for KVH Part Number 02-0899.

2 Installation

2.1 Overview of Installation

TracVision SA is designed for simple installation and setup. Just follow these easy steps:

1. Choose the antenna location.
2. Mount the antenna unit.
3. Connect the antenna unit cables.
4. Connect the antenna unit to the TV IRD.
5. Connect the TV IRD to the TV.

2.1.1 Installation Tools and Materials Required

- Electric drill
- $\frac{3}{16}$ "-drill bit and $\frac{1}{2}$ " hole saw and auger bit
- $\frac{1}{2}$ "-socket wrench
- #2 Phillips and #0 flat tip screwdrivers
- Augat Snap 'n Seal Crimp/Strip Tool (Part Number IT1000) if using the KVH-provided F-connector
- Silicone sealant or RTV
- Thread locker (as required)
- $\frac{7}{16}$ "-open end wrench
- Wire strippers
- Adhesive suitable for specific roof construction and materials (e.g., Liquid Nails)
- Rivet Gun and $\frac{3}{16}$ "-rivets (or other fastener suitable for specific roof construction)
- Terminal crimp tool
- Optional PC with terminal emulation software such as PROCOMM, Windows Terminal, or Windows 95 Hyperterminal



Plan the entire installation before proceeding! Take into account component placement, running cable distances between units, and accessibility to the equipment after installation.



The product serial number may be found in front of the antenna reflector on the rotating plate as well as on the [inside front cover](#) of this manual.



While some DIRECTV IRDs offer on-screen messages, it is recommended that a PC be available for all installations of both DIRECTV and EchoStar.

2.1.2 Kitpack

Table 2-1 lists the materials provided in the TracVision SA kitpack.

Table 2-1
Kitpack Contents

Part	Qty.	KVH Part No.
Rocker Switch	1	12-0048
Switch Plate	1	20-0685
RF F-Connector	2	23-0170
Terminal Crimp (female)	5	23-0188-03
Tie-wraps	5	22-0013
¼"-20 x ⅝" hex screws	4	14-0250-0010
¼" flat washers	4	14-0251
Flash kit cable and adapter	1	02-1029
Clam Shell Ventilator	1	19-0230

2.2 Choosing the Best Location

- Since the TracVision antenna requires a clear view of the southern sky to receive satellite signals, the ideal antenna site has an unobstructed view of the horizon/satellite all around.
- Keep the antenna clear of any obstructions on the roof (e.g., air conditioners). The antenna requires a 15° to 75° look angle to receive satellite signals.

Figure 2-1
Antenna Blockage

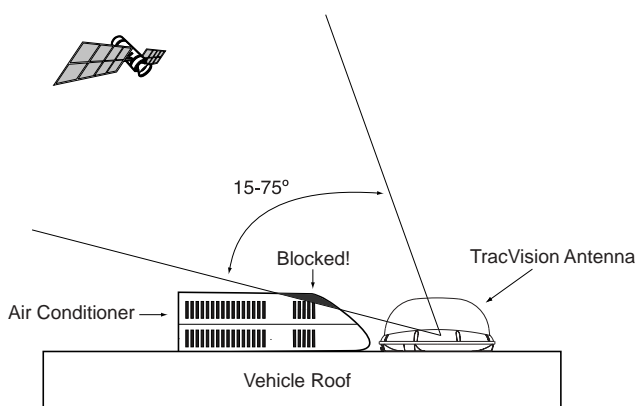

The liquid-tight connectors on TracVision SA may face either forward or backward along the centerline of the vehicle for more convenient installation.

- Consider the location of the antenna relative to the location of any equipment or necessary wiring within the vehicle.
- For best operation, mount the antenna on a horizontal surface.

2.3 Mounting the Antenna Unit

1. Remove antenna unit from shipping container.
2. Remove and save the 8 pan head screws and sealing washers that hold radome to baseplate. Carefully lift radome straight up until clear of antenna assembly and set aside.
3. Position antenna unit in desired location on the centerline of the vehicle with baseplate and mounting plate arrows facing in the same direction (either forward or backward). The proper orientation is illustrated in Figure 2-2.

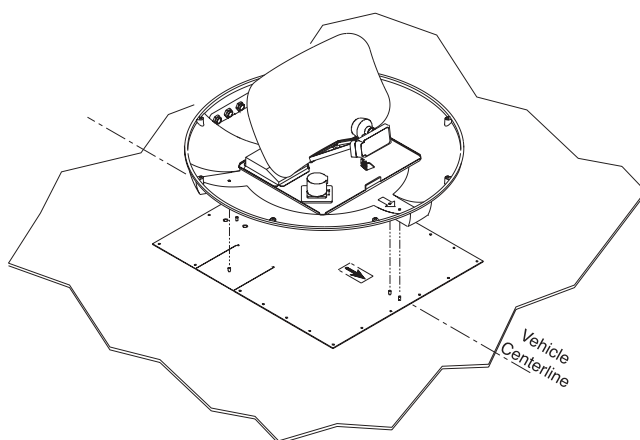

4. While the baseplate is in place, mark location(s) on roof for cable access to permit convenient cable access to the liquid-tight fittings on the back of the baseplate.
5. Cut the tie-wraps holding the antenna unit to the forward shipping restraint.

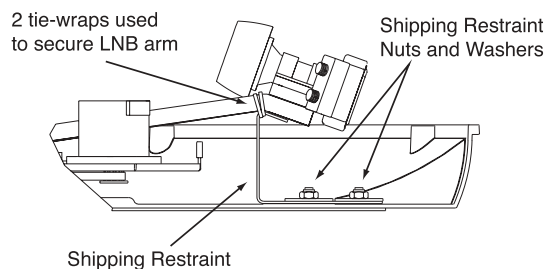

Always lift the antenna unit by the gray baseplate, never by the radome or any portion of the antenna assembly!

Figure 2-2
Proper Orientation of the Antenna Unit

Figure 2-3
Forward Shipping Restraint (Arranged for Shipping)

- Remove additional nuts and washers connecting baseplate and shipping restraints to the mounting plate. The positions of all three shipping restraints are pictured in Figure 2-4.

Figure 2-4

*TracVision SA Shipping Restraints
(Top View, Installed for Shipping)*



Do not discard the shipping restraints, washers, or the nuts. They should be saved for future use in case the antenna unit needs to be removed and shipped to another location. Four 1/4" x 5/8" hex head screws have been provided in the kitpack for shipping as the bolts used to hold the shipping restraint during initial shipping are integral parts of the mounting plate.

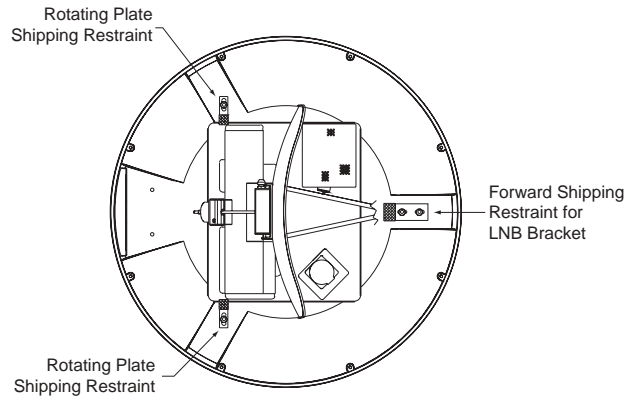

- Remove six 1/4"-20 hex nuts and washers that secure the Antenna Unit to the mounting plate.
- Remove antenna unit from mounting plate.
- The mounting plate allows the antenna unit to be mounted on a curved roof. While the perimeter of the mounting plate is secured to the vehicle with the appropriate fasteners, two flexible wings allow the rear mounting bolts to attach to the antenna baseplate. These may be angled upward to ensure a secure mounting, as shown in Figure 2-5.

Figure 2-5

Mounting the Unit on a Curved Surface

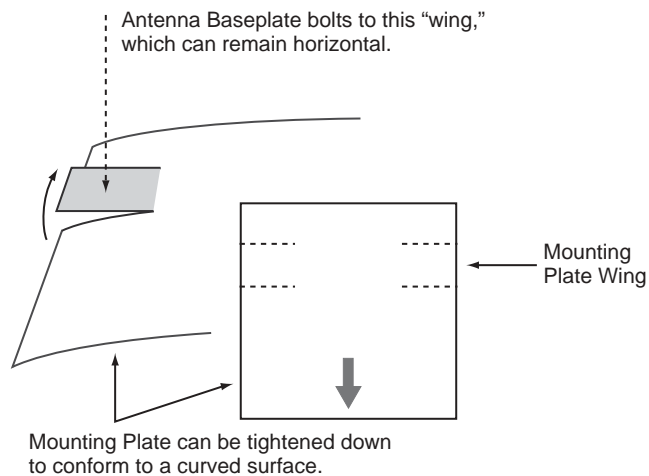

- Using the mounting plate as a template, drill four 3/16" holes through the roof of the vehicle at each of the four corners. Temporarily secure the mounting plate at the corners with rivets or screws.

11. With the corners secured, use the mounting plate as a template to mark and drill the remaining nineteen $\frac{3}{16}$ " holes through the roof of the vehicle. Remove plate and clean roof surface. The dimensions of the baseplate and locations of the drill holes are shown in Figure 2-6.

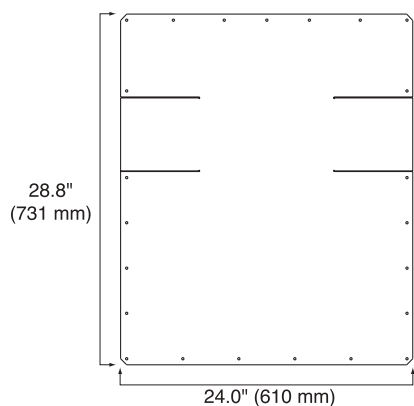

Figure 2-6
Mounting Plate Dimensions

12. Place the construction adhesive over all holes. If using a liquid construction adhesive, apply bead to mounting plate in a zig-zag pattern.
13. Reposition mounting plate over tape/adhesive and attach using $\frac{3}{16}$ "-diameter rivets (or appropriate fasteners). Seal all rivet heads and edges with silicone.
14. Drill cable access hole(s) in vehicle.
15. When unit is installed with connectors facing the rear of the vehicle, the factory-drilled drain holes are located as shown in Figure 2-7.

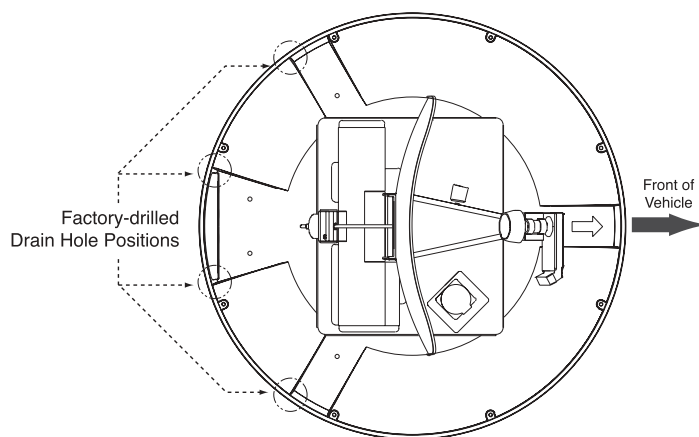

Figure 2-7
Connectors Facing Rear
of Vehicle – Factory-drilled
Drain Hole Locations

15a. (Alternate Drain Hole Locations) If the antenna unit is installed with the connectors facing the front of the vehicle, drill out $\frac{3}{16}$ "-drain holes in rear-facing side of baseplate as illustrated in Figure 2-8. The existing factory-drilled drain holes shown in Figure 2-7 must then be plugged with silicone rubber sealant.

Figure 2-8
Connectors Facing Front of Vehicle – Recommended Drain Hole Locations



You **MUST** drill out the drain holes as indicated to ensure that any moisture that enters the baseplate is able to drain. Ensure that factory-drilled holes are completely sealed.

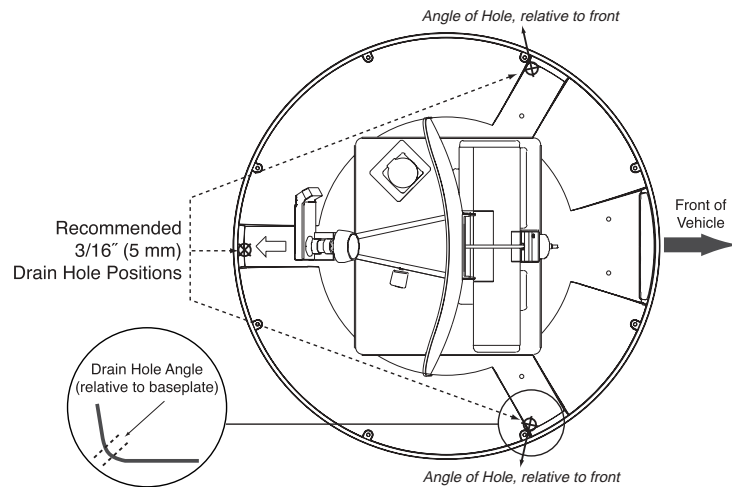

16. Place antenna unit on mounting plate and secure using nuts and washers removed in Step 7.

17. For convenient storage, the shipping restraints may be rotated 180° and secured to their original mounting bolts (see Figures 2-9 through 2-11).

Figure 2-9
Forward Shipping Restraint Storage

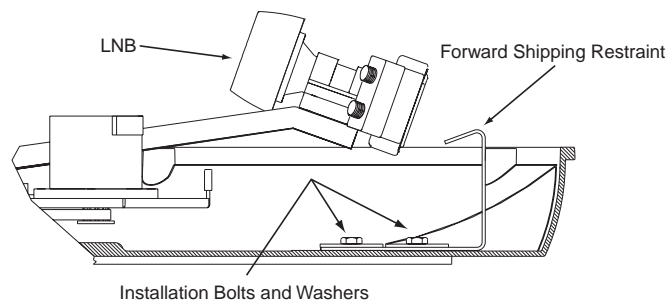
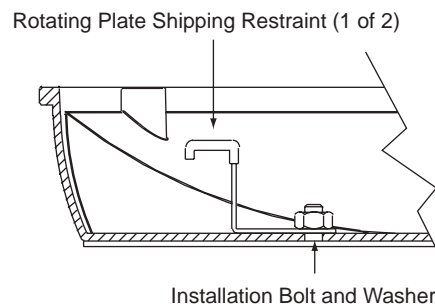

Figure 2-10
Rotating Plate Shipping Restraint Storage



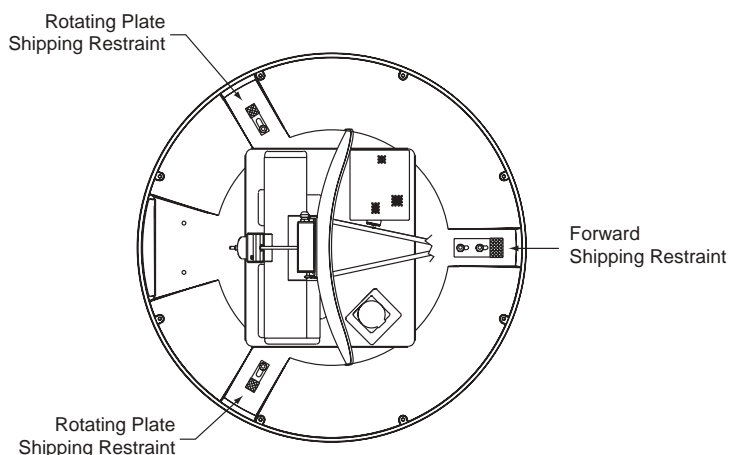

Figure 2-11
TracVision SA Shipping Restraints
(Storage Position)

18. Proceed to *Section 2.4, "Connecting the Antenna Unit,"* to wire the TracVision SA system. The radome will be placed back on the baseplate using the hardware removed in Step 2 after wiring and initializing the system.

2.4 Connecting the Antenna Unit

The following sections provide instructions for properly wiring the Antenna Unit to the IRD and to vehicle power.

Tips for Safe and Successful Wiring within the TracVision SA Baseplate

- When attaching cables to the TracVision SA terminal connector strips, make sure the insulation is stripped back approximately $\frac{1}{4}$ ". Twist the wires gently to help achieve a good connection. Do not pinch insulation inside the connector.
- After attaching the power and data cables to the appropriate terminal connector strips, tug gently to ensure a firm connection.
- After attaching cables within the TracVision SA baseplate, eliminate any unnecessary slack in the cables before tightening the liquid-tight fittings.
- Run the RF signal cable into the baseplate last. It will help keep the power and data cables clear of the antenna and LNB.



DO NOT leave an extra length of cable within the baseplate as a service loop. All service loops should be stored within the vehicle's cable access.

Figure 2-12
Proper Wire-to-Terminal
Connection

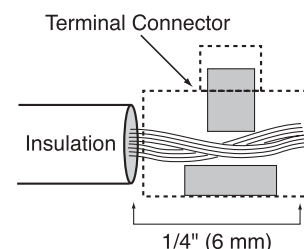
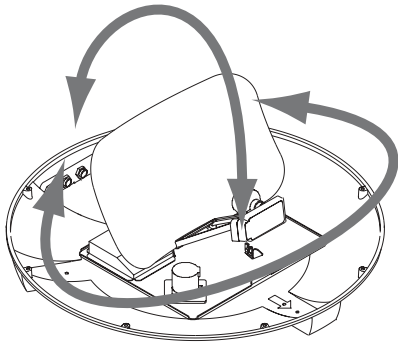

Figure 2-13
Moving the Antenna Reflector



- After hooking up all of the wiring and removing any slack, slowly rotate, raise, and lower the antenna reflector to make certain that the cables are all clear of any moving elements.
- Check to be certain that the elevation axis actuator motor shaft (pictured in [Section 5, Maintenance, Figure 5-2](#)) clears all cable connections.
- Completely seal all rooftop cable access holes.

TracVision SA Cable Ports

On one side of the baseplate are four liquid-tight fittings, which serve the dual purpose of relieving strain on the cables as well as providing a tight seal around the cable access ports.

Figure 2-14
Cable Port Assignments
(Exterior of Baseplate)

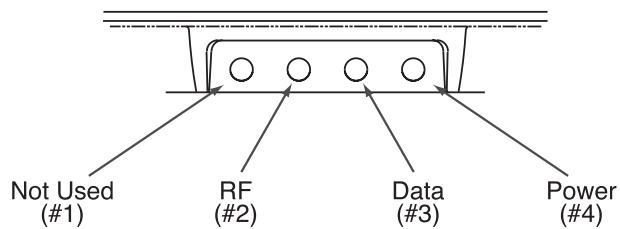

When wiring is done properly, the sets of cables will overlap each other, as illustrated in Figure 2-15.

Figure 2-15
Cable Overlap within the
TracVision SA Baseplate

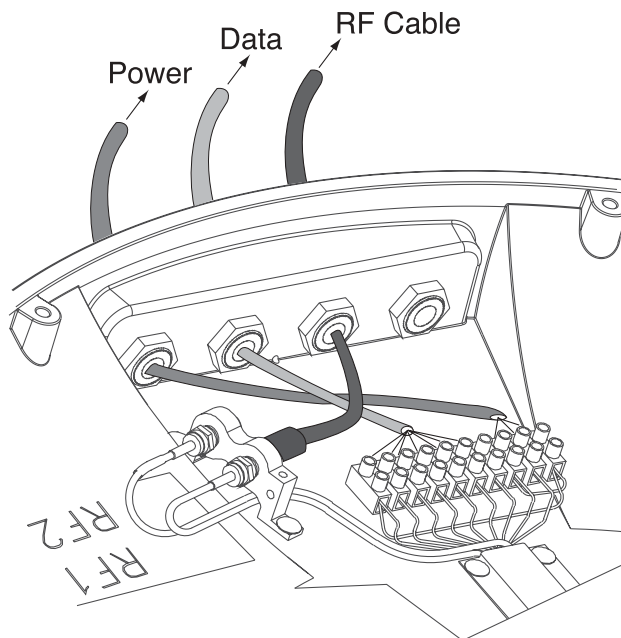

2.4.1 Connecting the Antenna Data Cable to the IRD

TracVision SA will not function properly unless you connect the data cable, the procedures for which vary based on your selected satellite TV service. The end of the data cable fitted with two DB9 connectors remains within the vehicle. This will be hooked up to the IRD as discussed later. For your reference, the pin assignments for the data cable DB9 connectors are detailed in [Appendix C](#). The other end of the data cable will be attached to the TracVision SA as described in the following section.

TracVision SA Data Cable Wiring Process

1. Feed the cable up to the roof and through the third liquid-tight fitting (#3) from the left as pictured in Figure 2-14.
2. Refer to Figure 2-16 for the proper arrangement of data cable wires within the terminal strip.
3. After connecting the data cable to the TracVision SA, hook up the other end to the IRD as described in the next subsections.

DIRECTV

The data cable for TracVision SA is equipped with a male DB9 (low-speed data port) connector. Connect the DB9 connector on the data cable to the low-speed data port on the back of the IRD.

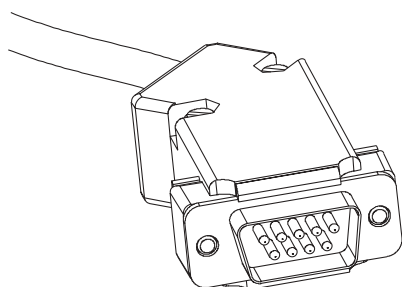

Wiring to an IRD with a DB15 Connector

Should the IRD only be equipped with a DB15 connector, follow the alternate wiring directions provided in [Appendix C](#).



All IRDs are susceptible to AC power fluctuations that can result in the IRD locking up and requiring a reset. Refer to [Section 4.2, “IRD Troubleshooting,”](#) for a solution to this issue.

Figure 2-16

Proper Terminal Strip Wiring Arrangement – Data Cable

Shield	1	Grnd
Red	2	+12v DC
Black	3	Grnd
Brown/White	4	RTN
Orange/White	5	PC_RXD
White/Orange	6	PC_TXD
Green/White	7	RTN
White/Blue	8	IRD_RXD
Blue/White	9	IRD_TXD
Shield	10	Grnd

Figure 2-17

DB9 Connector



This port is static-sensitive, so observe the proper precautions. Before starting, make certain that the IRD is not plugged into an AC outlet.

DISH Network

Unlike the DIRECTV IRDs, the EchoStar IRD used with the DISH Network is not equipped with a DB9 connector. As a result, you will need to purchase an EchoStar Adapter (KVH Part Number 02-0899).

The rear of the DISH Network IRD has a port labeled “High Speed Data Port.”

1. Remove the protective metal plate to expose the High Speed Data Port. (Save the screws and plate in the IRD packing material in case the unit must be returned for repairs.)
2. Install the KVH EchoStar Adapter as shown in Figure 2-18. Secure the Adapter to the IRD using the captive screws in the Adapter.

Figure 2-18
EchoStar Adapter Installation

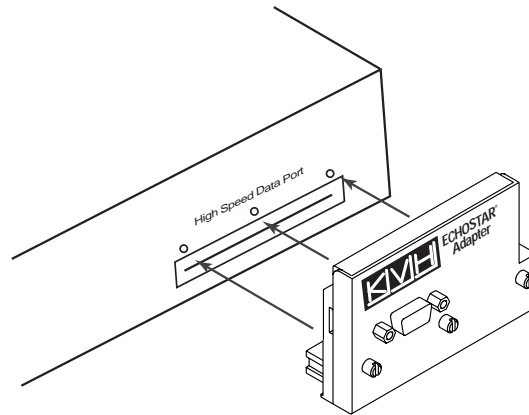

3. Connect the DB9 connector on the data cable to the EchoStar Adapter DB9.

Commissioning the IRD

Please refer to the user manual that accompanied your IRD for instructions on properly commissioning the system.

EchoStar Commissioning Issues

EchoStar IRDs that have not been commissioned within several months of manufacture require additional steps to complete the process. Refer to [Appendix D](#) for complete details.

2.4.2 Connecting the Antenna to Vehicle Power

Tips for Safe and Successful Wiring within the TracVision SA Baseplate

- When attaching cables to the TracVision SA terminal connector strips, make sure the insulation is stripped back approximately 1/4". Twist the wires gently to help achieve a good connection. Do not pinch insulation inside the connector.
- After attaching the power and data cables to the appropriate terminal connector strips, tug gently to ensure a firm connection.
- After attaching cables within the TracVision SA baseplate, eliminate any unnecessary slack in the cables before tightening the liquid-tight fittings.

Connecting to Vehicle Power

TracVision SA must be connected to a +12 volt DC, 2.5-3.5 amp power supply to operate. The supplied power cable should be run up to the antenna unit, through the far right liquid-tight fitting (#4 – refer to Figure 2-14), and wired to the terminal connector strip as illustrated in Figure 2-20.

TracVision SA comes equipped with a KVH standard 30-foot power cable, a rocker switch, and a switch panel. Power cables of other lengths are also available through KVH distributors.

Figure 2-21 on the following page illustrates the internal wiring arrangement for TracVision SA within the vehicle, including the supplied rocker switch. When wiring the rocker switch, it is recommended that the shield wire from the TracVision SA be connected to the chassis ground.

Figure 2-19

Proper Wire-to-Terminal Connection

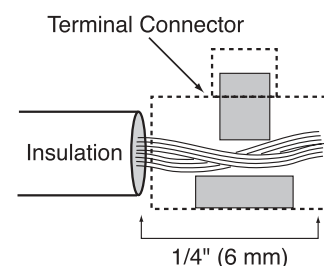

Figure 2-20

Proper Terminal Strip Wiring Arrangement – Power Cable

Shield	1	Grnd
Red	2	+12v DC
Black	3	Grnd
Brown/White	4	RTN
Orange/White	5	PC_RXD
White/Orange	6	PC_TXD
Green/White	7	RTN
White/Blue	8	IRD_RXD
Blue/White	9	IRD_TXD
Shield	10	Grnd

Figure 2-21
Wiring TracVision SA
to Vehicle Power



Before connecting the Antenna Unit to vehicle power, remove the appropriate vehicle fuse to prevent a short circuit. Replace the fuse after the connection to vehicle power is complete.

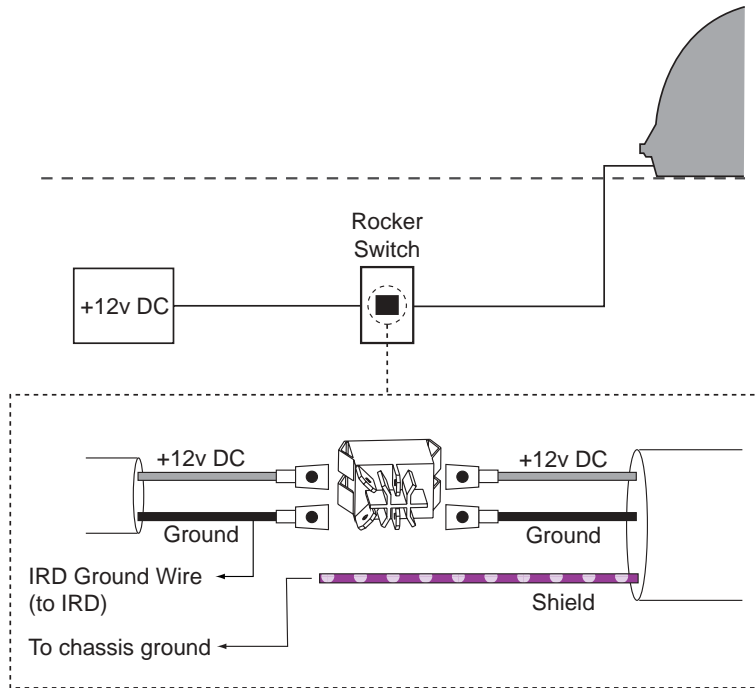

2.4.3 Connecting the IRD Ground Wire

A grounding wire has been provided to connect your IRD to a suitable ground and protect the system. Attach the grounding wire to any suitable screw on the rear panel of the IRD with a good contact with the IRD chassis. The other end should be connected to a suitable ground, ideally the ground connection at the rocker switch (see Figure 2-21).

2.4.4 Connecting the Antenna RF Signal Cable to the IRD



When shipped from the factory, the #1 liquid-tight fitting is sealed with a rubber stopper. Leave the stopper in the fitting unless you are going to install a dual output LNB and be connect a second RF cable to the TracVision SA.

The RF signal cable is fitted with an F-type connector at only one end and should be attached to TracVision SA and the IRD as follows:

1. Feed the bare end of the RF signal cable through the #2 liquid-tight fitting at the back of the TracVision SA baseplate and away from the dome. Leave the F-connector inside the TracVision SA baseplate (as pictured in Figure 2-22 on the following page).

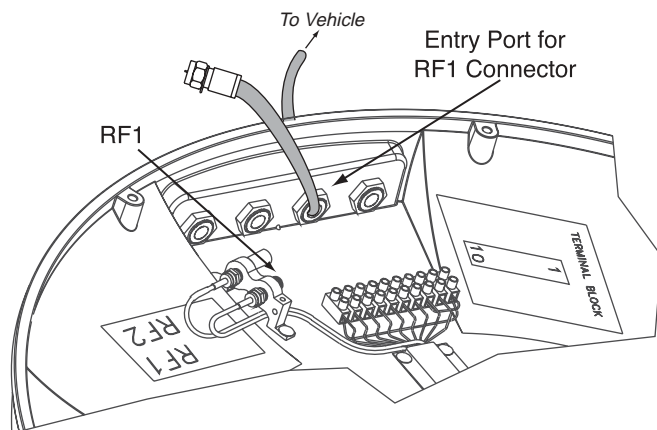

Figure 2-22
Connecting the RF Cable to TracVision SA

2. Connect the RF signal cable's F-connector to the plug labeled RF1.
3. Feed the bare end of the RF signal cable and pass through the cable hole drilled earlier and into the vehicle.
4. Attach the provided F-connector to the end of the RF signal cable inside the vessel as illustrated in Figure 2-23a-d, using an Augat Snap 'n Seal Crimp/Strip Tool, part number IT1000.
 - a. Slide compression fitting onto raw cable before beginning connector termination.



KVH has provided an F-connector for use with the TracVision SA. This connector specifically requires the Augat Snap 'n Seal Crimp/Strip Tool, part number IT1000.

If you do not have this tool, you will need to purchase a silicone-filled, weatherproof F-connector (Radio Shack Part Number 278-236 or equivalent) to use instead.

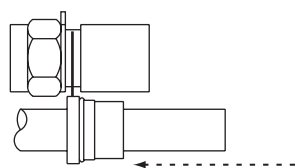

- b. Twist and break off connector body.

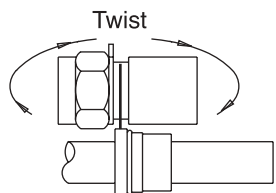

- c. Use Augat tool to strip center conductor and trim back overall jacket. Do not cut through braid.

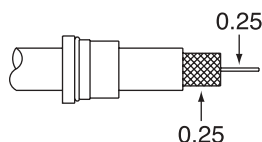
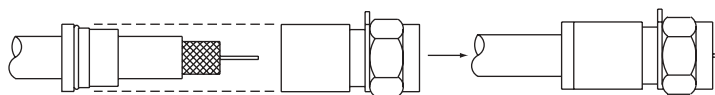

Figure 2-23a-d
Attaching the KVH-provided F-connector to an RF Cable

- d. Slide connector body onto the prepared cable. Slide the compression fitting up into the connector body. Use Augat tool to snap on the connector.



- 5. Attach the cable to the IRD connector labeled SATELLITE IN.

2.5 Checking Out the System

Power up the TracVision SA system and IRD and observe messages on your TV screen to verify proper operation. Some messages originate in the IRD, others are generated in the TracVision SA circuits.

Depending on your choice of satellite TV service and IRD, the system may display several text messages on the television screen to aid in monitoring TracVision SA performance. These messages are not displayed when the IRD is displaying the Signal Strength Meter on the TV screen. The messages and their meanings are described in Table 2-2.

Table 2-2
TracVision SA Operational Messages



The DISH Network and some newer IRDs (e.g., the Sony A50) give priority to internal IRD messages rather than on-screen messages. KVH recommends that the maintenance port must be used to read installation-related messages on a PC.

Message	Definition
KVH TracVision SA	Displays for 5 seconds at startup
Software Version	Current software version Alternates with "KVH TracVision SA"
Initializing	System initializing
Search Mode 1	Antenna Unit in Search Mode 1
Search Mode 2	Antenna Unit in Search Mode 2
Search Mode 3	Antenna Unit in Search Mode 3
Reacquisition	System is reacquiring the satellite
RF Signal Error	RF signal detector has no signal at input
AZ Motor Error	Fault detected in azimuth drive subassembly
EL Motor Error	Fault detected in elevation drive subassembly

Differences among IRD data ports may result in different message formats, and some messages may not be displayed on the television screen. DSS messages you may see are listed in Table 2-3.

Message	Definition
Searching for satellite – please stand by	The IRD is powered up and doesn't detect the satellite signal.
Searching for program guide – please stand by	The system has found the satellite, but has been turned off for more than approximately four hours. This message appears for about 10 seconds.

Table 2-3

DSS On-screen Messages

Refer to your DSS User's Manual for specific messages displayed by your system.

2.6 Completing the Installation Process

If the system has initialized properly and is functioning, replace the radome on the baseplate (labels on the sides), securing it with the eight pan head screws and flat washers removed at the start of the installation process.

As noted previously, while some DIRECTV IRDs offer on-screen messages, it is recommended that a PC be available for all installations of both DIRECTV and EchoStar. This will permit the installer to record the TracVision SA startup sequence to verify that the unit is functioning within specified parameters. Baseline startup parameters (with optimal ranges) have been provided in [Appendix E](#).



*If a need does arise to paint the radome, **ONLY use non-metallic automotive paint** to avoid degrading the RF signal strength and the reception quality.*

2.7 Configuring TracVision SA for Remote Satellite Dish Operation

In some campground locations, dense foliage will block the satellite signal. In these situations, a remote portable antenna may be the only solution to satellite signal reception.

The wiring option for the remote dish is very simple and should be installed when the TracVision is installed. A high-quality “A/B switch” should be used to change from TracVision to remote antenna operation. The recommended wiring arrangement for remote dish operation is illustrated in Figure 2-24.

Figure 2-24
Remote Dish Wiring Configuration

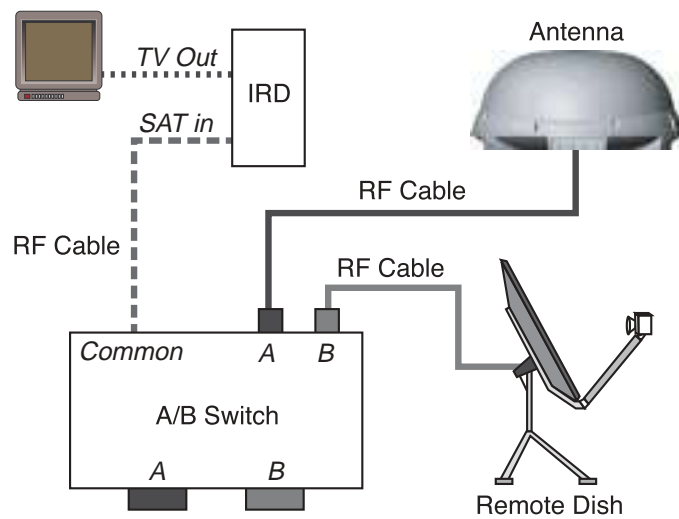

3 Operation

The TracVision SA system is easy to use. Antenna unit initialization and satellite acquisition is automatic and does not require any operator intervention.

To use the TracVision SA system, the vehicle must be stationary. Once the vehicle is parked:

1. Turn on the IRD and the television.
2. Apply operating power to the antenna unit.

Refer to your IRD user manual for complete operating instructions for the IRD.

A clear line of sight to the satellite helps ensure that the antenna can acquire and track the satellite.

The system carries out a number of automated steps at startup. For reference, these steps are outlined in Table 3-1.

Step	Actions
Antenna Unit Initialization	The microprocessor circuitry does a basic self-test of the hardware and software associated with the antenna unit.
IRD Identification	The microprocessor next queries the IRD to determine whether it is a DIRECTV or DISH Network IRD. Based on the IRD type, the system will then set various system variables to ensure that the correct satellite is found during Search Mode.
Satellite RF Threshold	The antenna is pointed at the north, south, east and west horizons to determine the background noise level and to calculate the minimum signal level required for satellite acquisition.
Satellite Search Modes	The system design includes three search modes to acquire the satellite.
Search Mode 1	The antenna makes three complete revolutions at the saved elevation.



As part of the startup process, the TracVision SA system will default to Channel 200, a program directory. This is the system's means of verifying that it has identified and is tracking the correct satellite.

Once Channel 200 appears, wait at least another 30 seconds before changing the channel to ensure that the system has completed its startup routine.

Table 3-1
TracVision SA Automated Procedures

Step	Actions
Reacquisition Search (Search Mode 2)	The antenna will search in a “window” of 6° around the satellite’s last known elevation.
Search Mode 3	The antenna conducts a complete sky search, making continuous revolutions at steadily increasing elevations (from 20° to 70°).
Fine-tuning/Satellite Verification	When a signal is detected, the antenna interrupts the search mode and begins a procedure to fine-tune the position for maximum signal strength. When the signal peak is found, the IRD is queried to determine if it can decode the peaked signal. If it is able to decode and lock onto the signal, then the system enters park mode.



It is highly recommended that you turn off the TracVision SA prior to moving the vehicle. TracVision SA will not track a satellite while the vehicle is in motion.

Using Your TracVision SA When Parked

When your vehicle is stopped, it is not necessary for the TracVision SA to be turned on. After parking your vehicle and confirming that the antenna is receiving the satellite signal, you may turn off the TracVision SA unit to avoid unnecessary use of power. The antenna will continue to receive the satellite TV signals and relay them to the IRD.

“Instant On” Operation

As part of its operation, TracVision SA routinely saves the satellite position to memory and retains it when the system is turned off. When TracVision SA is powered up, the system looks at the satellite’s last saved position. If the vehicle has not changed its location, the antenna will immediately acquire the satellite and receive the signal without initializing the antenna.

If the vehicle moves after TracVision SA is turned off, the Antenna Unit will quickly carry out its normal initialization routine to reacquire the satellite.

4 Troubleshooting

The troubleshooting matrix shown in Table 4-1 identifies some trouble symptoms, their possible causes, and references to troubleshooting solutions.

Table 4-1
Troubleshooting Matrix

SYMPTOM	POSSIBLE CAUSE (AND SOLUTION)										
	Blown fuse or lack of power (Section 4.1.1)	Dew or rain pooling on dome (Section 4.1.1)	Satellite signal blocked (Section 4.1.2)	Outside satellite coverage zone (Section 4.1.3)	Incorrect or loose RF connectors (Section 4.1.4)	IRD data port or cable/wiring (Section 4.1.5)	EchoStar IRD commissioning (Section 4.2.1)	Failed IRD status check (Section 4.2.3)	IRD fault (Section 4.2.4)	LNB assembly faulty (Section 4.3)	
Antenna non-functional	X										
No IRD status message					X	X		X	X		
No picture on TV set			X	X		X		X	X	X	
Intermittent picture for short intervals		X	X	X	X	X			X	X	
System will not find satellite		X	X	X		X	X	X	X	X	
Snowy television picture									X		
IRD locks up						X		X			
Picture jumbled, parts missing, freezing	X										

4.1 Causes and Remedies for Common Operational Issues

There are a number of common issues that can affect the signal reception quality or the operation of the TracVision SA. The following sections address these issues and potential solutions.

4.1.1 Blown Fuse or No Power

If the Antenna Unit is installed but entirely non-responsive, there are two key factors to check as part of the troubleshooting process:

1. Blown Fuse – The Antenna Unit is equipped with a fuse mounted on its CPU Board. If this fuse has blown or been broken, the Antenna Unit will not operate. Refer to [Section 5.4.1, “PCB Removal and Replacement,”](#) for details on the fuse location and how to access the CPU Board.
2. Wiring – If the system has been improperly wired, it will prevent the Antenna Unit from operating correctly. Refer to [Section 2.4.2, “Connecting the Antenna to Vehicle Power,”](#) for complete system wiring information.

4.1.2 Dew or Rain Pooling on Dome

Dew or rain can occasionally pool on the top of the radome. While this moisture will usually be dispersed when the vehicle is in motion, it can disrupt the signal while the vehicle is at rest. This issue can be minimized with two approaches:

1. Spray the dome with hosed water to remove the dew from the dome surface.
2. Periodically apply liquid dish detergent to the dome surface. Wipe the full-strength detergent on the dome and allow it to dry. This treatment will provide a film that will help moisture bead up and roll off the dome.



On-screen messages are not available with the DISH Network and some newer IRDs (e.g., the Sony A50).

4.1.3 Satellite Signal Blocked

Satellite signals can be blocked or degraded by trees and branches, buildings, mountains, overpasses, or equipment on the vehicle itself. Refer to [Section 2.2, “Choosing the Best Location,”](#) to make certain that the TracVision SA unit is in the optimal location. Simply moving the vehicle to clear an external obstruction will also restore signal quality.

4.1.4 Outside Satellite Coverage Zone

TracVision SA will provide outstanding reception throughout the entire coverage area for your satellite television service of choice. However, signal quality can be degraded as you approach the fringe coverage areas (e.g., Northern Maine). Refer to your satellite television service manual to check the viable coverage area.



For your convenience, KVH provides links to several web sites that offer satellite coverage information. Simply go to our web site at www.kvh.com/footprint/index.html.

4.1.5 Incorrect or Loose RF Connectors

As part of preventive maintenance (described in [Section 5, "Maintenance,"](#)) KVH recommends checking the Antenna Unit cable connections. A loose RF connector can reduce the signal quality. Refer to [Section 2.4.4, "Connecting the Antenna RF Signal Cable to the IRD"](#) for directions on proper Antenna Unit to RF cabling.



Baseline RF levels are included as part of the startup sequence provided in [Appendix E](#).

4.2 IRD Troubleshooting

The IRD that was provided with your satellite television service may also be the cause of less-than-ideal operation.

4.2.1 IRD Data Port or Cable/Wiring

Refer to [Section 2.4.1, "Connecting the Antenna Unit Data Cable to the IRD"](#) and your IRD user manual to confirm that the IRD is properly connected to the Antenna Unit and the television.

4.2.2 AC Power Fluctuating

If the system periodically displays a picture for less than one minute, then enters Search Mode 1, the IRD data port may be locked up as the result of power fluctuations and will require a reset. This can be verified by hooking up a PC to the data port and checking for error messages. Reset must be done by:

1. Completely shutting down DC power to the antenna.
2. Remove the AC source, either at the breaker or by unplugging the IRD.
3. Wait at least 10 seconds before restoring power first to the IRD and then to the antenna.



The long-term fix, typically done at original system installation, is to install an Uninterruptible Power Supply (like those available for use with computer systems) on the IRD. Be sure to specify a UPS with adequate available current for all devices attached to it. (An IRD draws approximately 200 watts.)

4.2.3 EchoStar IRD Commissioning Check

If you have purchased a DISH Network system, there is a chance that your EchoStar IRD will fail to acquire the satellite when you first activate it. This has been known to happen in IRDs that have not been commissioned within several months of their manufacture. [Appendix D](#) provides the manual satellite acquisition and commissioning procedure.

4.2.4 Failed IRD Status Check

As detailed in [Appendix E](#), TracVision SA completes a detailed startup routine whenever it is turned on. One of the first checks is the IRD status test. As noted in the typical startup cycles, the expectation is that the IRD and its communications link to TracVision SA will pass this test. There are, however, two alternate results, each indicating a slightly different problem.

Test Result: NONE

If the system tests achieves a result of **NONE**, there is no communication at all between the antenna unit and the IRD.

Solution

Check to be certain the IRD and TracVision SA are connected properly at the low-speed data port. Refer to [Section 2.4, "Connecting the Antenna Unit,"](#) for correct Antenna Unit to IRD wiring procedures and diagrams. After verifying the connection, cycle the power on and off and review the startup test results.

Test Result: UNKNOWN

In the instance of a result of **UNKNOWN**, a communications link exists, but the data received by the antenna unit is garbled and unrecognizable.

Solution

As with a result of **NONE**, first check to be certain the IRD and TracVision SA are connected properly at the low-speed data port. Refer to [Section 2.4, "Connecting the Antenna Unit,"](#) for correct Antenna Unit to IRD wiring procedures and diagrams. After verifying the connection, cycle the power on and off and review

the startup test results. If this does not initially succeed, refer to [Section 4.2.2, “AC Power Fluctuating,”](#) and follow the IRD reset procedure.

4.2.5 IRD Faulty

In the case of a faulty IRD, refer to your IRD user manual for service, replacement, and warranty information.

4.3 LNB Faults

[Section 5, “Maintenance,”](#) provides detailed instructions for authorized service personnel who may be required to replace the TracVision SA LNB.

4.4 Computer Diagnostics

TracVision SA has been designed to provide diagnostic readouts viewed on the TV screen (DSS only) or on a personal computer having an RS-232 serial communication port. If you are unable to isolate a system problem with the foregoing troubleshooting tools, set up for computer diagnostics as described below. System problems will most likely be found somewhere through the diagnostic readouts.

The diagnostics procedure requires terminal emulation software such as PROCOMM, Windows Terminal, or Windows 95 Hyperterminal. Use the settings appropriate to your application.

1. Connect one end of the PC cable to the DB9 connector on the switchplate. Connect the other end to the serial port on the PC (a 9-pin/25-pin connector adapter may be needed for some PCs).
2. Open the terminal emulation software and establish the following settings:
 - 9600 baud
 - no parity
 - 8 data bits
 - 1 start bit
 - 1 stop bit
 - no flow control



Most terminal emulation programs have a parameter for local character echo. Select this parameter to see what is being typed without any system delay.

3. Apply power to the TracVision SA system and allow the system to complete full initialization. Data should be scrolling on the PC display to identify any system problems detected. If no data is seen, recheck your connections and the terminal software setup.

4.5 Maintenance Port Parser Commands

TracVision SA system parser commands are detailed in [Appendix F](#).

5 Maintenance

5.1 Warranty/Service Information

KVH Industries, Inc. warrants the KVH product purchased against defects in materials for a period of TWO (2) years and against labor costs for a period of ONE (1) year from the date of original retail purchase by the original purchaser. It is the customer's responsibility to verify the date of purchase by returning the warranty card included with the product to KVH within 30 days of purchase, or by providing a copy of a dated sales receipt for the KVH product under warranty with the warranty claim. If this date cannot be verified, the warranty period will begin 30 days after the date of manufacture of the original product purchased.

For additional information on KVH warranty, repair, and liability policies, please refer to the [complete warranty statement](#) provided at the conclusion of this manual.



The serial number of your TracVision SA will be required during any troubleshooting or service calls. You will find the serial number on the [inside front cover](#) of this manual as well as in front of the antenna reflector on the rotating plate.

5.2 Preventive Maintenance

TracVision SA requires minimal preventive maintenance. The following tasks are sufficient to maintain peak performance.

Monthly

- Wash the exterior of the radome and baseplate assembly with fresh water; a mild detergent may be added to remove grime. Do not spray the radome directly with high-pressure water.
- Do not apply abrasive cleaners or volatile solvents such as acetone to the ABS radome.

Annually

- Remove the radome and examine the interior of the Antenna Unit for signs of corrosion, loose connections, or frayed or broken wires.
- Visually inspect the elevation drive shaft to be certain that it moves easily and is clear of grit and debris. Clean and lubricate with silicone or white lithium grease as required.

5.3 Replaceable Parts

TracVision SA has been designed with durability and low maintenance in mind. If you experience an operating problem or otherwise require technical assistance, contact your local authorized TracVision SA dealer/installer first. Have the Antenna Unit serial number ready with a list of the trouble symptoms. If an authorized dealer/installer is not located nearby, contact the factory directly at the telephone, facsimile, or e-mail listings inside the front cover.

Replacement part numbers for units that can be serviced in the field are listed in Table 5-1. These parts may be obtained from any KVH authorized dealer/installer.

Table 5-1
Field Replaceable Units



Should the fuse ever need to be replaced, TracVision SA uses a 5x20mm, 4-amp, 250-volt fast-blow fuse.

Part Name	Part Number
Radome Assembly	02-0953-02
Baseplate Assembly	02-0952-02
Power Cable	32-0590-30
Data Cable	32-0591-30
RF Cable	32-0589-30
EchoStar Adapter Unit *	02-0899
CPU PCB	02-1043-01
System Fuse	16-0017-4000
LNB	19-0194

* Optional, purchased separately

It is recommended that all other technical difficulties be resolved by returning the TracVision SA unit to an authorized service provider.

5.4 Field Replaceable Unit Procedures

The following subsections provide detailed procedures for repairing or swapping out field replaceable units. The procedures refer to labeled items presented on the following isometric diagrams, which are based on KVH assembly drawings.



Always lift the antenna unit by the gray baseplate, never by the radome or any portion of the antenna assembly!

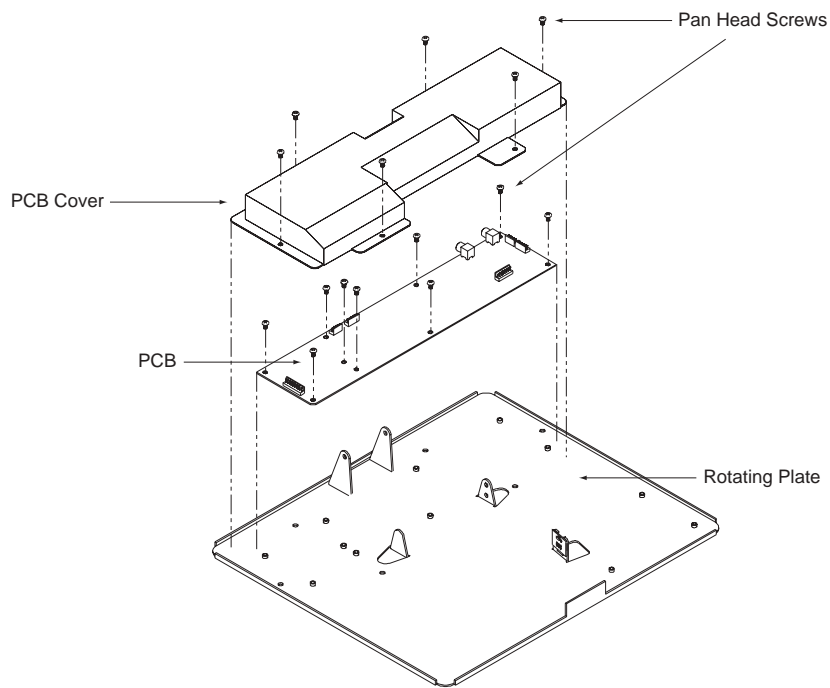

Figure 5-1
Antenna, PCB, and Rotating Plate

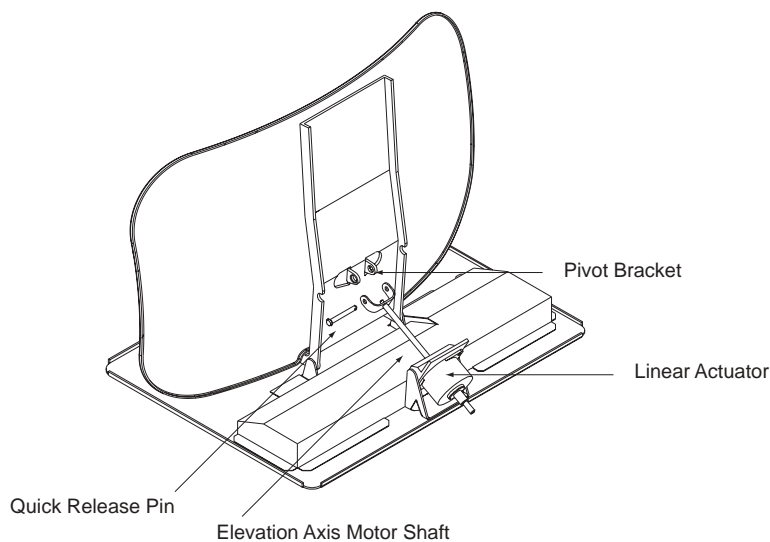
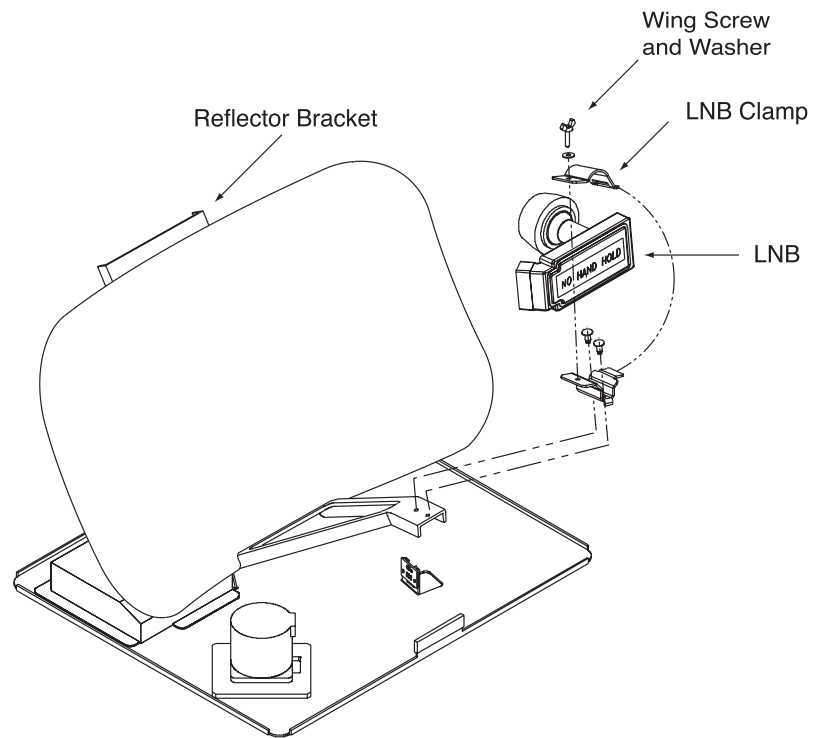

Figure 5-2
Close-up of Linear Actuator,
Pivot Bracket, and Pin

Figure 5-3
Antenna Assembly



5.4.1 PCB Removal and Replacement

Estimated Time to Repair: ½ hour

The microprocessor PCB assembly is protected by a cover fastened to the rotating plate – *Fig. 5-1*. The cover must be removed to gain access to the main power fuse and the PCB assembly.



When carrying out maintenance on the PCB, be sure to not drop any of the small screws inside the mechanism. If a screw is lost within the baseplate, it must be retrieved to avoid causing any damage when the unit rotates.

1. Remove the quick release pin from the pivot bracket – *Fig. 5-2*.
2. Remove the elevation axis motor shaft from the linear actuator – *Fig. 5-2*.
3. Remove 6 pan head screws from the PCB cover flanges. Remove the PCB cover – *Fig. 5-1*.
4. Remove cable connectors from PCB. Figure 5-4 on the following page illustrates the PCB arrangement and connector locations.
5. The PCB is mounted to the rotating plate with 9 pan head screws.

Figure 5-4
PCB Connector Locations –
Rear View

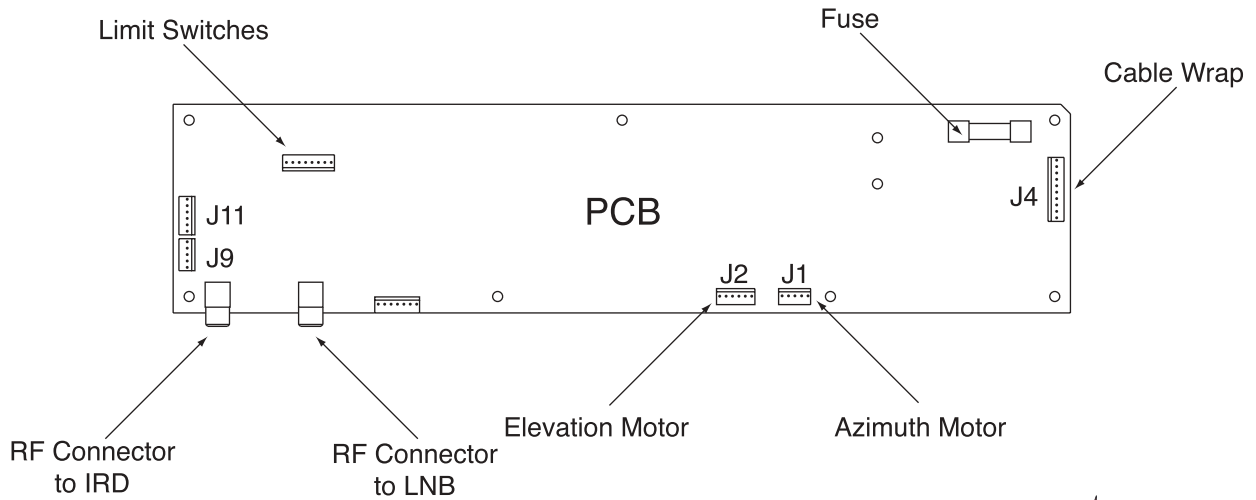

6. Reverse this process to install the replacement PCB. Reinstall all cable connectors removed in Step 4.
7. Carry out the LNB calibration procedure (Section 5.4.2).



TracVision SA is equipped with a 5x220 mm, 4-amp, 250 volt fast-blow fuse, which is mounted on the PCB. To access and replace the fuse, remove the PCB cover.

5.4.2 Antenna LNB Replacement

Estimated Time to Repair: ½ hour

The LNB receives preamplifier operating power from the IRD via the PCB – Fig. 5-1 and 5-3. Be certain that the IRD is disconnected from its power source before removing or reconnecting the LNB.

1. Disconnect both RF coaxial connectors at the LNB.
2. Remove the wing screw and washer from the LNB clamp – Fig. 5-3.
3. Remove the top of the LNB clamp – Fig. 5-3.
4. Remove the LNB.
5. Replacement is the reverse of this procedure. Check the rotation to ensure that the LNB is not striking any wires or the baseplate.



When replacing the LNB, make certain to restore it to its original orientation, as shown in Figure 5-3.

Antenna LNB Normalization and Stability Test

1. Type **HALT<cr>** to put the system into Idle Mode.
2. Type **DEBUGON<cr>** to put the system into Debug Mode.
3. Type **FINDSAT<cr>** to begin the automatic signal peaking process. Wait until the antenna peaks the satellite signal and is motionless. The screen will display **FINDSAT:PASS**.
4. Type **=CALLNB<cr>** to start the LNB Normalization Function.

Note: The CALLNB Function requires the antenna to be pointed directly at the satellite peak before performing this routine.

5. The system must respond with the following message: **CALLNB: PASS**. If the system displays **CALLNB: FAIL**, return to step 1 and retry the procedure, making sure to achieve the highest possible RF signal peak.
6. Record the Cold Sky Average and the RFGAIN value reported in step 5.
7. Type **ZAP<cr>**. The system will re-initialize using the new RFGAIN and RFOFFSET scale factors displayed following step 5.
8. Wait for the system to perform the background noise calculation. Read the Average Noise Level value from the messages transmitted out the maintenance port. This value must be greater than 300 and less than 1300. An example of the message sequence and format is as follows:

*** Averaging Background Noise ***

Average Noise Level = 750

Noise Threshold = 1450

9. Wait for the system to search for, find the satellite, enter Tracking Mode and track the satellite for a minimum of 30 seconds. Record the average RF signal value reported from the +POS: AZ, EL, RF messages. An example of the message sequence and format is as follows:

+POS: 154.5 33.2 2521



The CALLNB Function requires the antenna to be pointed directly at the satellite peak before performing this routine. Using the FINDSAT command will ensure that the antenna is receiving the strongest possible signal.

10. The RF signal values while tracking shall be greater than 2000 and less than 3000.

5.4.3 EchoStar Adapter Replacement

Estimated Time to Repair: ½ hour

Use the following procedure to replace the EchoStar Adapter:

1. Remove power from Antenna and unplug IRD from AC power.
2. Observe static precautions.
3. Unscrew and remove DB9 cable connector from the Adapter.
4. Unscrew thumbscrews securing Adapter to IRD.
5. Carefully remove Adapter from IRD card edge.
6. Install new Adapter on the IRD card edge. Secure the Adapter and reinstall cable.

5.5 Preparation for Shipment

If it is necessary to repack the Antenna Unit for shipment, the shipping restraints removed or stowed during installation must be replaced. Follow these steps to reinstall the restraints.

1. Rotate the antenna unit so that the LNB is facing forward (away from the liquid-tight fittings).
2. Attach the three restraints to the baseplate using the 1/4"-20 x 5/8" long hex screws and washers (provided as part of the kitpack), and nuts (removed from shipping restraint during installation) as pictured in Figure 5-5.

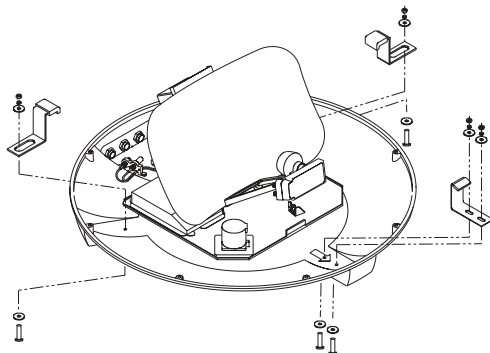

When rotating the azimuth mechanism by hand, go slowly! Hitting the mechanical stops with excessive force will damage the azimuth limit switch.

Figure 5-5

Attaching the Shipping Restraints to the Antenna Baseplate

3. Place the antenna bracket on the forward shipping restraint.
4. Secure the forward restraint and bracket by wrapping two tie-wraps around the bend in the forward restraint and the antenna bracket (at the end of the LNB bracket).

Figure 5-6
Securing the Forward Shipping Restraint

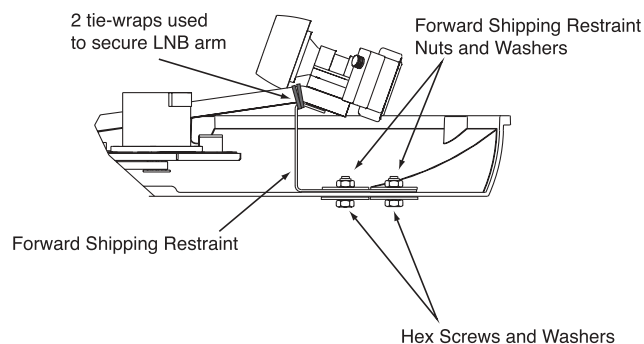

5. Place the entire Antenna Unit into its shipping box using the original packaging material, as illustrated in Figure 5-7.

Figure 5-7
Repackaging the TracVision SA

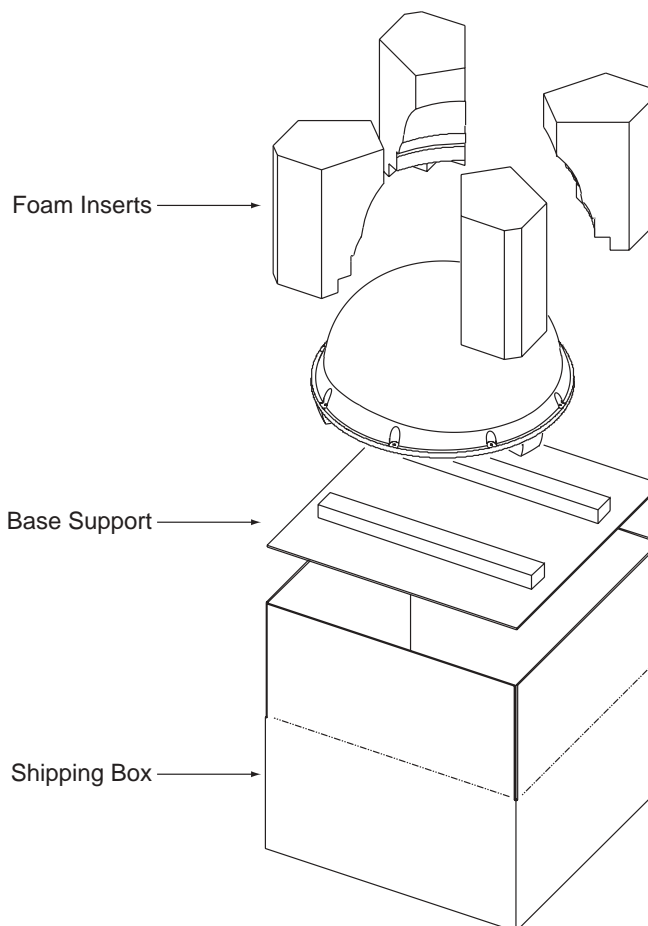

Appendix A

System Specifications

Physical Characteristics

Power	11-16 volts DC @ 2.5 amps nominal, 3.5 amps peak
Dimensions/Weight	32" (81 cm) wide x 14.8" (38 cm) high, 33 lbs (15 kg)
LNB	Single Output
Maintenance Port	9600 bps, 8,N,1,EIA, RS232

Table A-1

TracVision SA System Specifications

Pointing System

Elevation Range	15° to 75°
Azimuth Range	720°
Position Repeatability	0.1°

Environmental

Operating Temperature	-25°C to +55°C
Storage Temperature	-40°C to +85°C
Humidity	to 100 percent

Appendix B

Functional Block Diagram

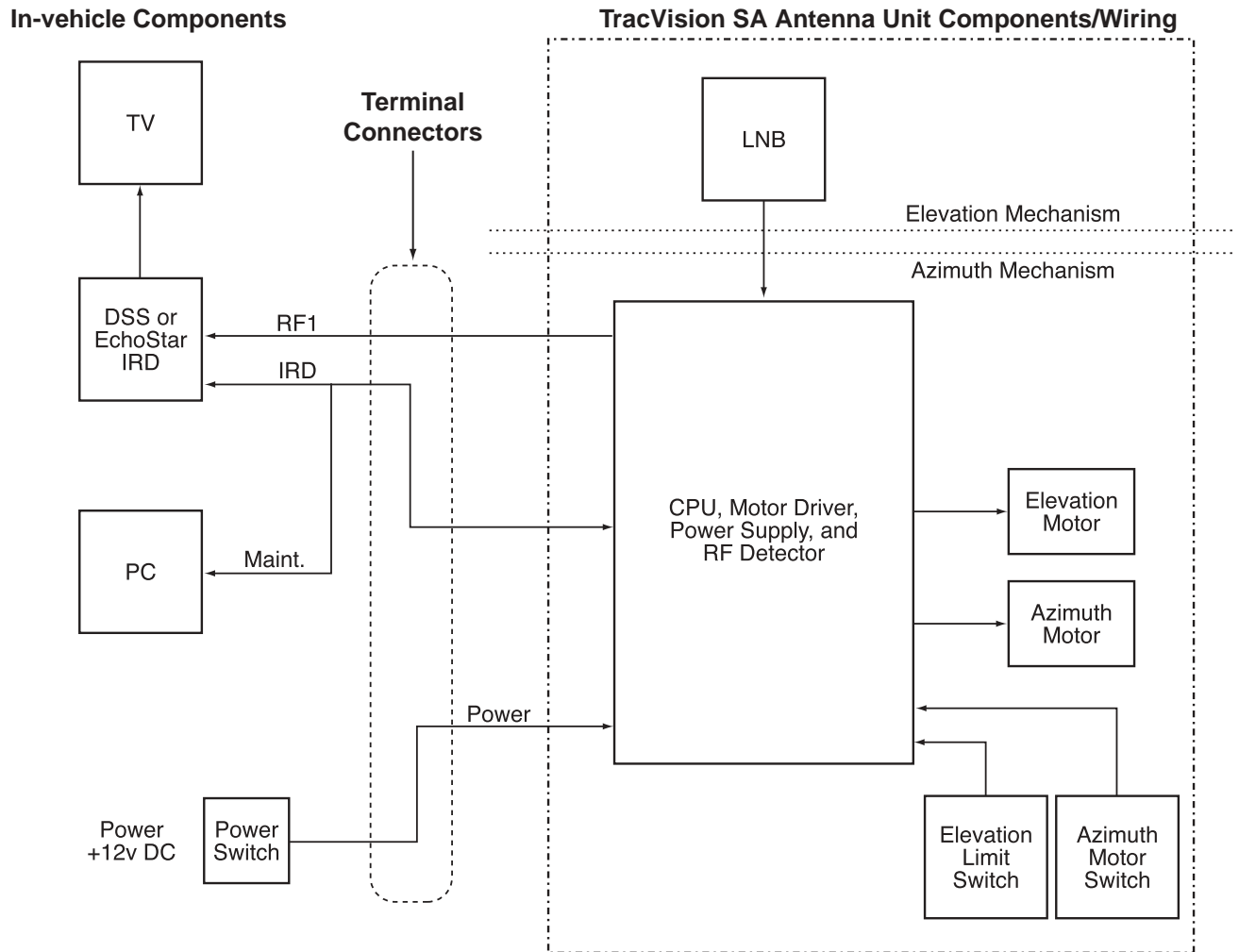

Cable Assignments

- RF1.....RF Cable (32-0589-30)
- IRD/Maint.....Data Cable (32-059-30)
- Power.....Power Cable (32-0590-30)

Appendix C

Data Cable Wiring

C.1 Wiring TracVision SA to a 15-pin Data Connector

In some instances, the IRD provided with a satellite TV service may be equipped with a 15-pin connector (DB15 wide-band data port), rather than a 9-pin connector (DB9 low-speed data port). There are two methods that will allow a TracVision SA system to function through a DB15 port.

Splicing a DB15 Connector to the Data Cable

It is possible to splice a DB15 connector to the TracVision SA data cable after removing the male DB9 connector. The alternate wiring arrangement is as follows:

DB9 Pin	Wire Color	Function	DB15 Pin
2	Blue/White	TXD	14
3	White/Blue	RXD	6
5	Green/White	GND	7

Table C-1

Alternate Wiring Arrangement for TracVision SA Data Cable to DB15 (15-wire) Connector

Creating a DB9-to-DB15 Adapter

It is also possible to construct a DB9-to-DB15 adapter that will remove the need to cut and splice the data cable. When constructing such an adapter, follow the DB9-to-DB15 pin arrangement detailed in Table C-1.

C.2 DB9 Data Connector Pin Assignments

During the troubleshooting or maintenance process, it may be necessary to check the DB9 data connectors to ensure that it is operating properly. With that in mind, Figure C-1 and Table C-2 detail the pin assignments for both the male and female DB9 connectors.

Table C-2
DB9 Pin Functions and Color Code

From Connector	Wire Color	Function
Male Connector Pin 2	Blu/Wht	DSSTXD
Male Connector Pin 3	Wht/Blu	DSSRXD
Male Connector Pin 5	Grn/Wht	DSSGND
Female Connector Socket 2	Org/Wht	PCRXD
Female Connector Socket 3	Wht/Org	PCTXD
Female Connector Socket 5	Brn/Wht	PCGND

Figure C-1
DB9 Male and Female Connector Arrangement

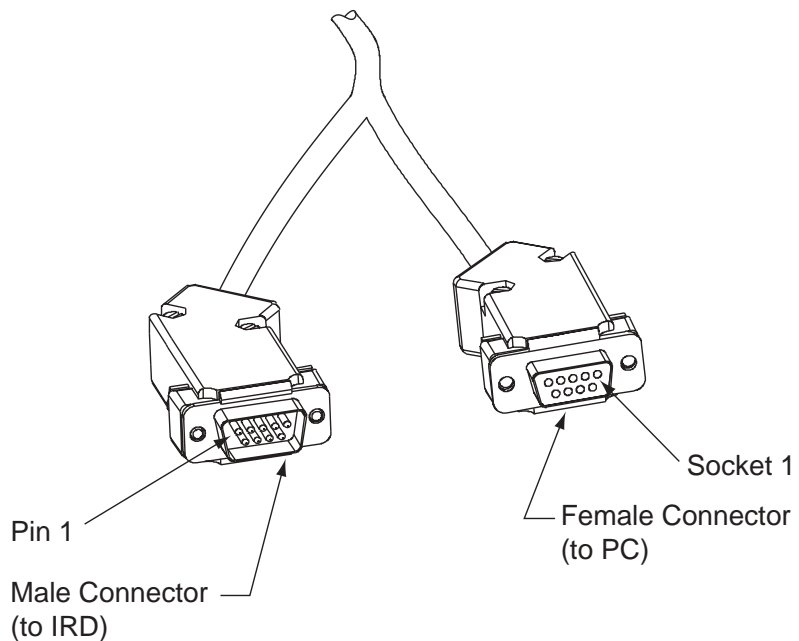

Appendix D

EchoStar IRD Commissioning Procedure

If you have purchased a DISH Network system, there is a chance that your EchoStar IRD will fail to acquire the satellite when you first activate it. This has been known to happen in IRDs that have not been commissioned within several months of their manufacture. The following process is a manual method of acquiring the satellite for the first time so that the IRD can download the most up-to-date satellite and programming data, allowing it to automatically acquire the satellite from then on.

Please refer to your EchoStar IRD user manual for complete instructions on the IRD, the remote control, and the command screens.



It will be necessary to have a PC available to complete the manual acquisition and commissioning procedure.

Manual Satellite Acquisition and IRD Commissioning

1. Turn on TV and EchoStar IRD.
2. Using EchoStar remote, press MENU.
 - The Main Menu will come up on the Screen.
3. Select #6, System Setup.
4. Select #1, Installation.
5. Select #1, Point Dish/Signal.
 - The Signal Strength Screen will appear.
6. Using remote, select the zip code box on the screen, and input the local zip code.
 - The screen will show you the Azimuth and Elevation to the satellite. Write this down.
7. Connect a PC to the data port.
8. Turn on the TracVision SA.
9. Type **HALT <CR>** after receiving the message
*** Entering Search Mode 1 ***.
10. Type in the elevation that you obtained in step 6.



The Signal Strength Meter is located on the bottom of the "Point Dish and Signal Strength" screen. This Signal Strength Meter is Red in color, and turns Green when the proper satellite is located.



Turning the IRD off with the remote puts IRD in standby mode. Turning the IRD off from the front panel shuts IRD off.

- Type **EL,xxx<CR>**
(e.g., Elevation of 30.2° = **EL,302<CR>**)
- 11. Using a compass, take a bearing on an object that is approximately on the azimuth obtained in step 6.
- 12. Type in an azimuth that points the antenna in the direction of the object selected in step 11.
 - Type **AZ,xxxx<CR>**
(e.g., Azimuth of 233° = **AZ,2330<CR>**)
 - Valid azimuth range is 0-360° (0000-3600)
- 13. Check to see if there is signal strength on the Signal Meter Screen.
- 14. Move antenna counter-clockwise in 5° increments until signal strength is acquired. If you do not find satellite, point the antenna at the object selected in step 11 and move antenna clockwise in 5° increments until signal strength is acquired.
- 15. Once satellite is found, fine tune azimuth in 1° increments for maximum signal strength.
- 16. Fine tune in elevation in 1° increments for maximum signal strength.
- 17. Once the satellite is found, turn the EchoStar IRD off, using the power button on the infrared remote. *Do not turn off the IRD using the front panel.* Leave IRD in standby mode for approximately 5 minutes. The IRD will now download new software from the satellite.
 - To verify that the IRD has been updated, put the IRD into the Signal Strength Screen mode, and three satellite options will appear on the left side of the screen: 61.5° West, 119° West, 148° West. Your EchoStar IRD is now updated.
- 18. Turn the TracVision SA off and then on. The EchoStar IRD will now communicate with the TracVision SA system. To verify this, monitor data port information. The following message will appear.

*** Initializing IRD ***

IRD STATUS: PASS ECHO

Appendix E

Startup Data Sequence

The data on the following pages presents two startup data sequences registered by the TracVision SA. The first is the standard, full initialization routine. The second routine is that registered by TracVision SA if it is turned on and acquires the satellite via the “Instant On” operation (described in [Section 3, “Operation.”](#)) These sequences can be recorded using the data port and a PC.

Standard Startup Sequence

?PGM

KVH TracVision SA Rev X - Version X.XX - Serial Number XXXXXXXXX

Limit Switch Test

Limit Switch Status: PASS-----PASS is expected

*** Initializing IRD ***

..

IRD STATUS: PASS DSS -----PASS is expected with successful IRD identification

Saved Sat Pos: EL = 33.4

*** Averaging Background Noise ***

+POS: 45.0 26.6 735

+POS: 57.9 20.0 1004

+POS: 232.0 20.0 812

+POS: 25.6 20.0 898

Average Noise Level = 957

Noise Threshold = 1781

Saved Sat Pos: EL = 33.4

*** Entering Search Mode 1 ***

+POS: 80.9 32.1 1217

+POS: 44.6 33.4 853

Satellite Found: AZ = 327.7, EL = 33.4, RF = 2476

+POS: 306.4 33.4 1020

*** Initializing Finetune ***-----Peaking the satellite signal

+POS: 327.7 33.4 2827

+POS: 327.7 33.9 2717

Signal Peaked: AZ = 327.69, EL = 33.40, RF = 2822

+POS: 327.7 33.3 2751

+POS: 327.7 33.3 2741

*** Entering Satellite Check ***

+POS: 327.7 33.3 2756

Signal Detected = 82

+POS: 327.7 33.3 2727

```
+POS: 327.7 33.3 2734
+POS: 327.7 33.3 2748
Signal Detected = 81
+POS: 327.7 33.3 2731
+POS: 327.7 33.3 2712
+POS: 327.7 33.3 2674
+POS: 327.7 33.3 2713
Tracking DSS satellite at 101.5W
+POS: 327.7 33.3 2665
IRD Signal Quality = 79
+POS: 327.7 33.3 2681
+POS: 327.7 33.3 2708
Saved Sat Pos: AZ = 327.70, EL = 33.34
```

"Instant On" Startup Sequence

?PGM

KVH TracVision SA Rev K - Version 5.05 - Serial Number 12345678

Instant On-----System skips limit switch test

Limit Switch Status: PASS-----PASS is expected

*** Initializing IRD ***

...

IRD STATUS: PASS DSS -----PASS is expected with successful IRD identification

Saved Sat Pos: EL = 33.3

*** Initializing Finetune ***-----Peaking the satellite signal

+POS: 360.0 33.9 2622

Signal Peaked: AZ = 0.00, EL = 33.30, RF = 2674

+POS: 0.0 33.3 2646

+POS: 0.0 33.3 2638

IRD Signal Quality = 79

+POS: 0.0 33.3 2640

+POS: 0.0 33.3 2616

+POS: 0.0 33.3 2614

IRD Signal Quality = 77

CH = 200 XP = 7 HI = 0 LO = 10

+POS: 0.0 33.3 2652

Saved Sat Pos: AZ = 0.00, EL = 33.30

+POS: 0.0 33.3 2617

+POS: 0.0 33.3 2616

IRD Signal Quality = 78

+POS: 0.0 33.3 2610

Appendix F

Maintenance Port Parser Commands

TracVision SA system parser commands are parsed when the system receives an ASCII carriage return (Hex 0D). An ASCII line feed (Hex 0A) is permitted but is ignored in any transmitted command. All system responses are terminated with an ASCII carriage return followed by a line feed and ending with either an acknowledge character (ASCII > (Hex 3E)) or a not-acknowledge character (ASCII ? (Hex 3F)). The parser commands are shown below in boldface capital letters but they are not case-sensitive. In most cases the command is responded to with an echo; that is, if you type **ZAP**, for example, and press "ENTER," the response will be the command you have entered (i.e., **ZAP**). For other commands the response is specific for each command, such as **VERSION**, **STATUS**, or **HELP**.

F.1 System Commands

Software Version

Function	reports software version
Command	VERSION
Argument	none
Response	KVH TVSA Version XX.XX

Table F-1
System Commands

System Status Report

Function:	reports general system status
Command:	STATUS
Argument:	none
Response:	system status string, (TBD)

Initialize the System

Function:	initializes the system (perform a soft reset)
Command:	ZAP
Argument:	none
Response:	echoes the command, then reinitializes the system

F.2 Manual Positioning Commands

To execute the following commands, first put the Antenna Unit in idle mode by typing **HALT** and pressing "ENTER." Positioning commands may be entered after the antenna comes to rest.

Table F-2
Manual Positioning Commands

Help on Parser Commands

Function:	lists parser commands
Command:	HELP
Argument:	none
Response:	print a list of all parser commands

Azimuth Angle

Function:	commands a manual azimuth angle that the mechanism moves to
Command:	AZ,xxxx (range is 0000-3599)
Argument:	desired azimuth angle of the mechanism relative to vehicle reference, or baseplate fwd, 000°-359.9° (vehicle-referenced)
Response:	echoes the command; mechanism moves at a fixed velocity

Elevation Angle

Function:	commands a manual elevation angle that the mechanism moves to
Command:	EL,xxx (range is 100-700)
Argument:	desired elevation angle of the mechanism relative to up, or external sensor attitude reference, 10.0°-70.0°
Response:	echoes the command; mechanism moves at a fixed velocity

Azimuth CW Step

Function:	commands a 0.1 deg CW manual step in azimuth angle
Command:	6
Argument:	none
Response:	echoes the command

Azimuth CCW Step

Function:	commands a 0.1 deg CCW manual step in azimuth angle
Command:	4
Argument:	none
Response:	echoes the command

Elevation UP Step

Function:	commands a 0.1 deg UP manual step in elevation angle
Command:	8
Argument:	none
Response:	echoes the command

Elevation DOWN Step

Function:	commands a 0.1 deg DOWN manual step in elevation angle
Command:	2
Argument:	none
Response:	echoes the command

F.3 Operational Commands

Idle Mode

Function:	halts active tracking and conical scan, then enters idle mode
Command:	HALT
Argument:	none
Response:	echoes the command

Table F-3
Operational Commands

F.4 Target and Signal Commands

Table F-4
Target and Signal Commands

Report Target Location

Function:	reports the target (satellite) location in the baseplate frame and uses the saved satellite position
Command:	TGTLOCATION
Argument:	none
Response:	Target Location = E XXX, A XXXX

Report RF Signal Strength

Function:	reports the modified signal strength from the RF power detector circuit, and applies the RF gain and offset computed during LNB calibration
Command:	SIGLEVEL
Argument:	none
Response:	Signal Strength = XXXX

Report IRD Signal Quality

Function:	reports the signal strength from the IRD; it uses the last received signal quality and initiates a new signal quality request command from the IRD
Command:	SIGQUALITY
Argument:	none
Response:	Stale Signal Quality = XX

Report IRD Type

Function:	reports the IRD connection type as DSS, EchoStar, untested, or none
Command:	IRDTYPE
Argument:	none
Responses:	IRD type has not been tested yet. IRD type is Echostar. IRD type is DSS. IRD type cannot be determined.

KVH Industries Limited Warranty

TracVision SA

Limited Warranty on Hardware

KVH Industries, Inc. warrants the KVH product purchased against defects in materials for a period of TWO (2) years and against labor costs for a period of ONE (1) year from the date of original retail purchase by the original purchaser. It is the customer's responsibility to verify the date of purchase by returning the warranty card included with the product to KVH within 30 days of purchase, or by providing a copy of a dated sales receipt for the KVH product under warranty with the warranty claim. If this date cannot be verified, the warranty period will begin 30 days after the date of manufacture of the original product purchased.

If you discover a defect, KVH will, at its option, repair, replace or refund the purchase price of the product at no charge to you, provided you return it during the warranty period, transportation charges prepaid, to the factory direct. Please attach your name, address, telephone number, a description of the problem and a copy of the bill of sale or sales receipt as proof of date of original retail purchase, to each product returned to warranty service. Alternatively, you may bring the product to an Authorized KVH TracVision Dealer for repair. If the product was installed by an Authorized KVH TracVision Dealer (identified with the KVH Authorized TracVision dealer list), KVH will cover the dealers' labor charges for warranty repairs, provided the dealer contacts KVH for pre-approval of the charges.

This Limited Warranty does not apply if the product has been damaged by accident, abuse, misuse or misapplication or has been modified without the written permission of KVH; if any KVH serial number has been removed or defaced; or if any factory-sealed part of the system has been opened without authorization.

Return Authorization

A Return Material Authorization is required prior to returning the product to KVH Industries. Please call our Technical Support Department at (401) 847-3327 or send an e-mail to techs@kvh.com to obtain the RMA number. Write the number in large, clear characters on the outside of the box. To avoid confusion and misunderstandings, shipments without an RMA number clearly visible on the outside box will be refused and returned to you at your expense. If possible, use the original box and packing material to protect the equipment from damage in shipment. KVH assumes no responsibility for warranty shipments from the customer to the factory if not shipped in the manner prescribed above.

THE EXPRESS WARRANTIES SET FORTH ABOVE ARE THE ONLY WARRANTIES GIVEN BY KVH WITH RESPECT TO ANY PRODUCT FURNISHED HEREUNDER; KVH MAKES NO OTHER WARRANTIES, EXPRESS, IMPLIED OR ARISING BY CUSTOM OR TRADE USAGE, AND SPECIFICALLY DISCLAIMS ANY WARRANTY OF MERCHANTABILITY OR OF FITNESS FOR A PARTICULAR PURPOSE. SAID EXPRESS WARRANTIES SHALL NOT BE ENLARGED OR OTHERWISE AFFECTED BY TECHNICAL OR OTHER ADVICE OR SERVICE PROVIDED BY KVH IN CONNECTION WITH ANY PRODUCT.

KVH's liability in contract, tort or otherwise arising out of or in connection with any product shall not exceed the price paid for the product. IN NO EVENT SHALL KVH BE LIABLE FOR SPECIAL, PUNITIVE, INCIDENTAL, TORT OR CONSEQUENTIAL DAMAGES OR LOST PROFITS OR GOODWILL (INCLUDING ANY DAMAGES RESULTING FROM LOSS OF USE, DELAY IN DELIVERY OR OTHERWISE) ARISING OUT OF OR IN CONNECTION WITH THE PERFORMANCE OR USE OR POSSESSION OF ANY PRODUCT, OR ANY OTHER OBLIGATIONS RELATING TO THE PRODUCT, EVEN IF KVH HAS BEEN ADVISED OF THE POSSIBILITY OF SUCH DAMAGES.

If any implied warranty, including implied warranties of merchantability and fitness for a particular purpose, cannot be excluded under applicable law, then such implied warranty shall be limited in duration to ONE (1) YEAR from the date of the original retail purchase of this product by the original purchaser.

Some states do not allow the exclusion or limitation of implied warranties or liability for incidental or consequential damages, so the above limitations may not apply to you. This warranty gives you specific legal rights, and you may also have other rights which vary from state to state.



KVH Industries, Inc.

50 Enterprise Center Middletown, RI 02842 U.S.A.
Phone: (401) 847-3327 Fax: (401) 849-0045
E-Mail: info@kvh.com Internet: <http://www.kvh.com>

KVH Europe A/S
Ved Klaedebo 12 2970 Hoersholm Denmark
Phone: +45 45 160 180 Fax: +45 45 867 077
E-Mail: info@kvh.dk Internet: <http://www.kvh.com>