

A Guide to TracVision LF owner's manual

- Installation Instructions
- User's Guide
- Technical Manual



TracVision LF Owner's Manual Addendum



(ECO #s 6119 and 6008)

The following information applies to Revision B of the TracVision LF Owner's Manual (KVH Part Number 54-0194).

Several improvements have been made to the TracVision LF system. The maintenance port connector has been moved from the antenna's baseplate to the switchplate, allowing a technician to hook up a laptop while inside the vehicle when conducting maintenance. In addition, the data/power connector on the baseplate has been simplified and a protective cover has been added to the switchplate to guard against damaging electrostatic discharges (ESD), which may occur during installation.

1.2 TracVision LF System Overview

Figure 1-1 has been changed to show the new baseplate connectors and the new PC maintenance connection to the switchplate.

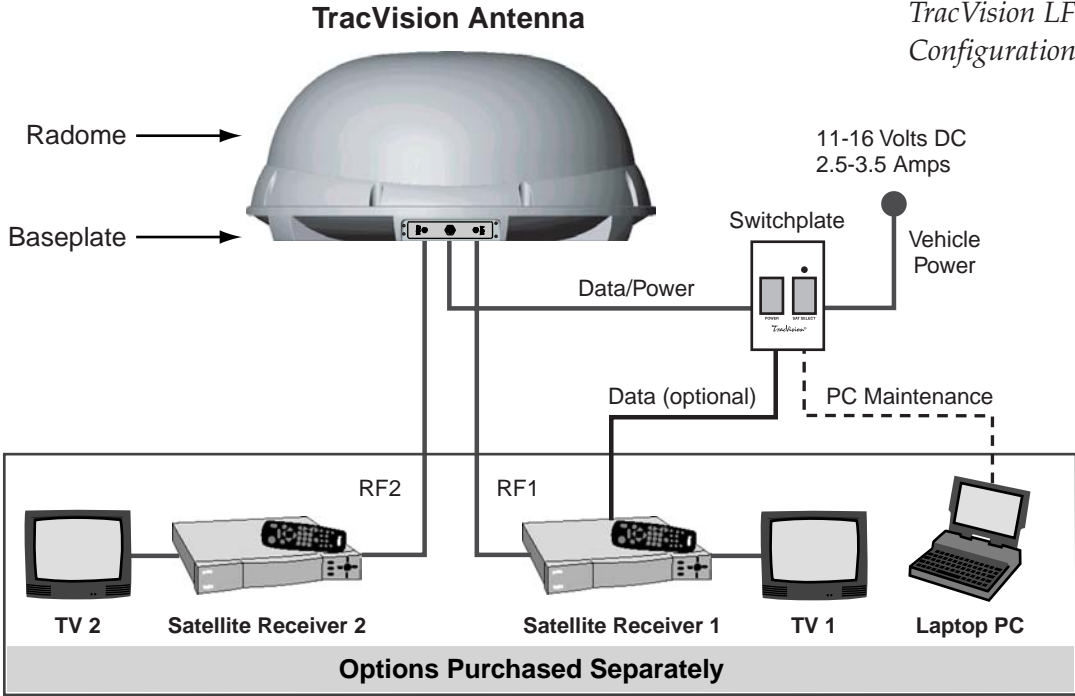

Figure 1-1
TracVision LF System Configuration

1.3 Materials Provided with TracVision LF

Table 1-1 shows the new part number for the data/power cable, which now has the same type of connector at each end.

Component	KVH Part No.
Antenna Unit	01-0225-15
RF Cable (28 ft)*	32-0417-28
Data/Power Cable (28 ft)*	32-0730-28
Kitpack**	72-0120
Installation and Operation Manual	54-0194

* RF and data/power cables may be supplied separately.

** A complete listing of kitpack contents is provided in [Table 2-2](#).

Table 1-1

TracVision LF Packing List

2.3 Connecting System Components

Figure 2-5 has been changed to show the new switchplate cutout dimensions, which have been widened to accommodate the protective cover. A revised, full-size template has also been provided on page 7 of this addendum. Figure 2-6 shows the new antenna baseplate connectors.

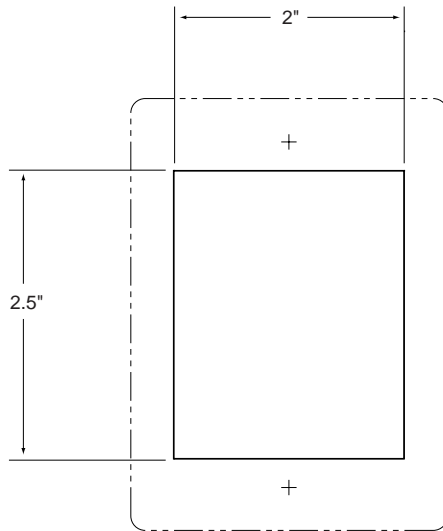

Figure 2-5

Switchplate Cutout Dimensions

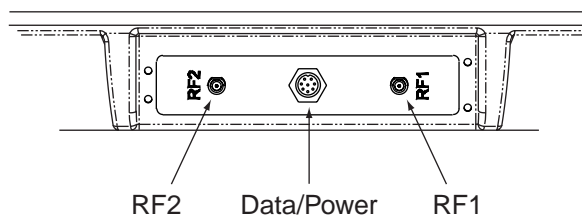

Figure 2-6

Antenna Baseplate Connectors

Figure 2-7 shows the switchplate connectors as they appear within the new cover. Note that the DB9 connector now serves as the system's maintenance port.

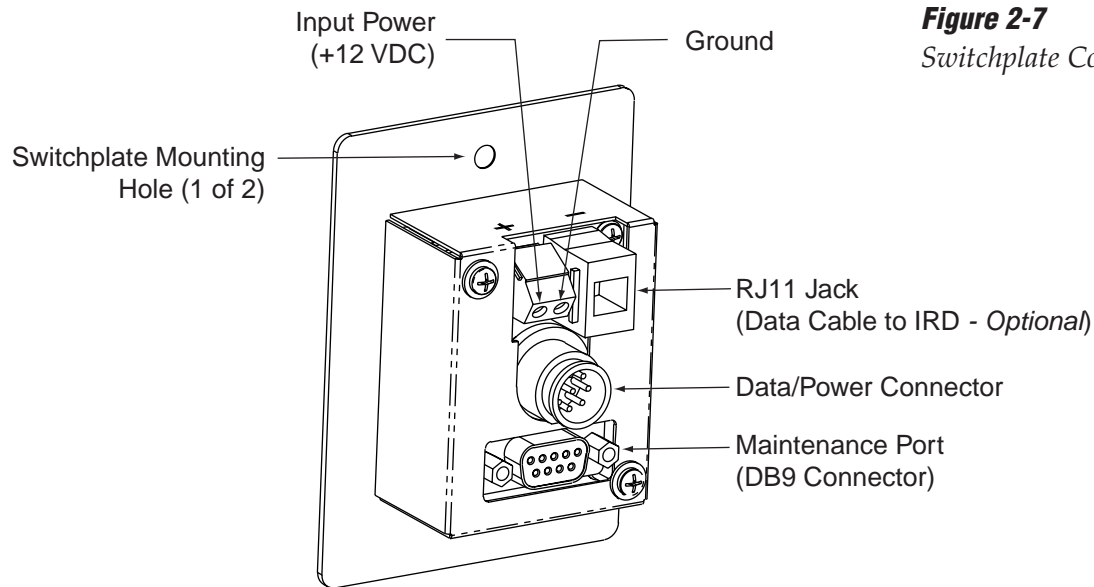

Figure 2-7
Switchplate Connectors

2.3.1 Connecting the Antenna to the Switchplate

The data/power cable no longer has a threaded connector end. Both ends of the cable have identical connectors.

1. Connect **one end** of the antenna data/power cable to the antenna's data/power connector and lock in place (see [Figure 2-6](#)).
2. Route the other end of the data/power cable down through the cable access hole in the vehicle's roof and out through the switchplate panel cutout.
3. Connect the data/power cable to the switchplate's data/power connector and lock in place (see [Figure 2-7](#)).

2.5.2 Checking Out the System Without an IRD Data Connection

and

4.4 Computer Diagnostics

Both of these sections explain how to connect a PC to the system's maintenance port. This step has been changed to reflect the new maintenance port location.

1. Connect one end of a PC data cable to the maintenance port connector on the switchplate (see Figure 2-10 or 4-1). *To access this connector, you may need to remove the switchplate from the mounting surface.* Connect the other end to the serial port on the PC (a 9-pin/25-pin connector adapter may be needed for some PCs).

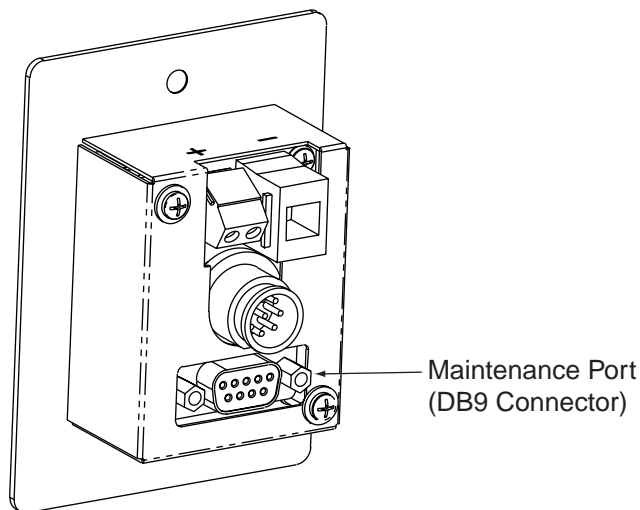

Figure 2-10 or 4-1
Switchplate Maintenance Port

5.3 Replaceable Parts

Table 5-1 has been changed to show the new part numbers for the baseplate assembly and data/power cable.

Part Name	Part Number
Radome Assembly	02-0953-08
Baseplate Assembly	02-1244-01
Data/Power Cable	32-0730-28
RF Cable	32-0417-28
CPU PCB	02-1144-01
Antenna Gyro	02-1035
Antenna Gyro Gasket	24-0139
System Fuse	16-0017-3150
LNB	19-0056

Table 5-1
Field Replaceable Units

Appendix B Comprehensive TracVision LF System Wiring Diagram

The wiring diagram on the following page has been changed to show the new location of the maintenance port.

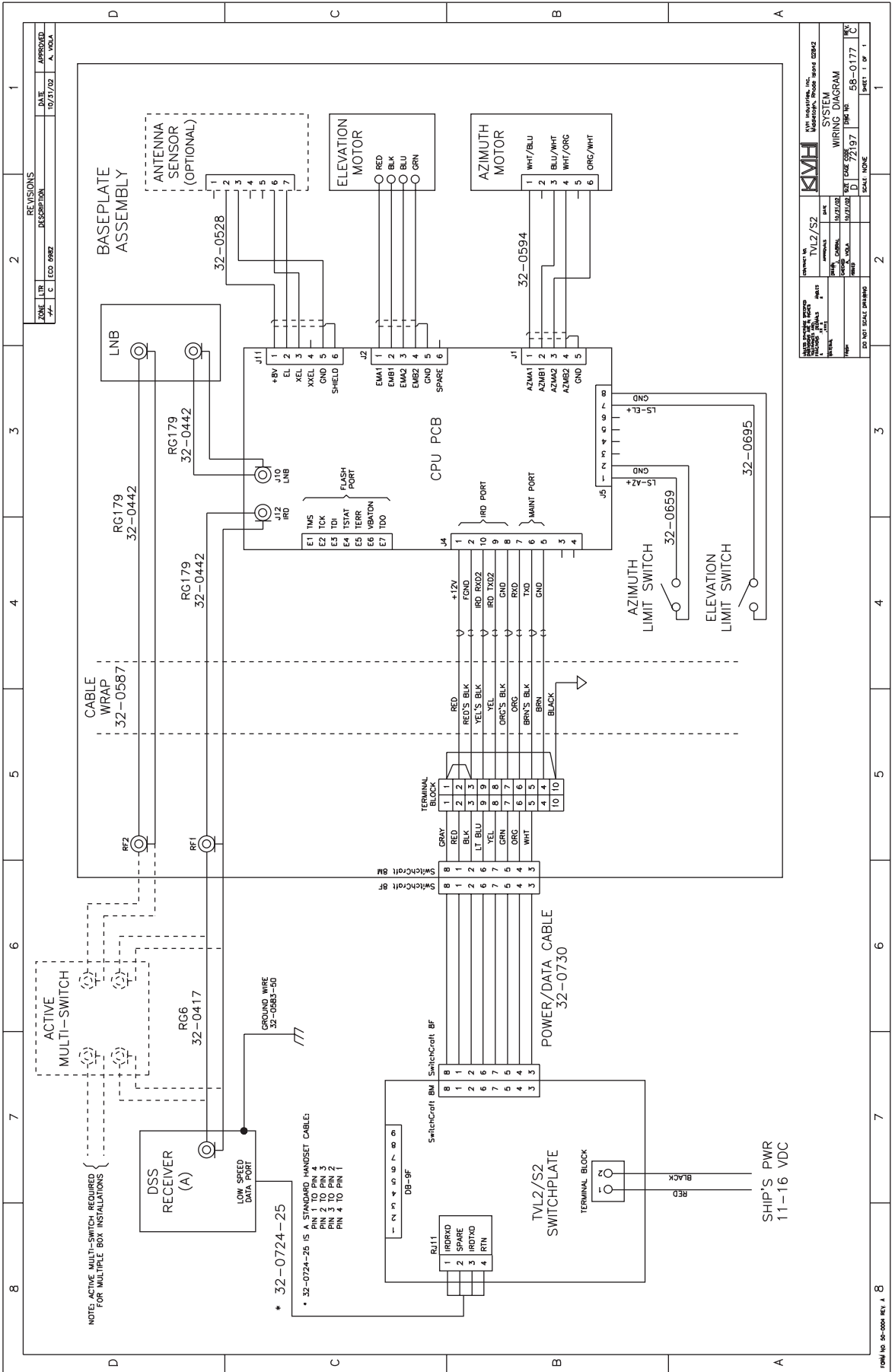

REV. NO.	DATE	DESCRIPTION	APPROVED
1	10/27/02	ISSUE	A. WUSA

REV. NO.	DATE	DESCRIPTION	APPROVED
1	10/27/02	ISSUE	A. WUSA

SHIP'S PWR 11-16 VDC

WIRING DIAGRAM

58-0177

SHEET 1 OF 1

Appendix C

Switchplate Template



The template has been changed to show the new cutout dimensions, which have been widened to accommodate the protective cover.

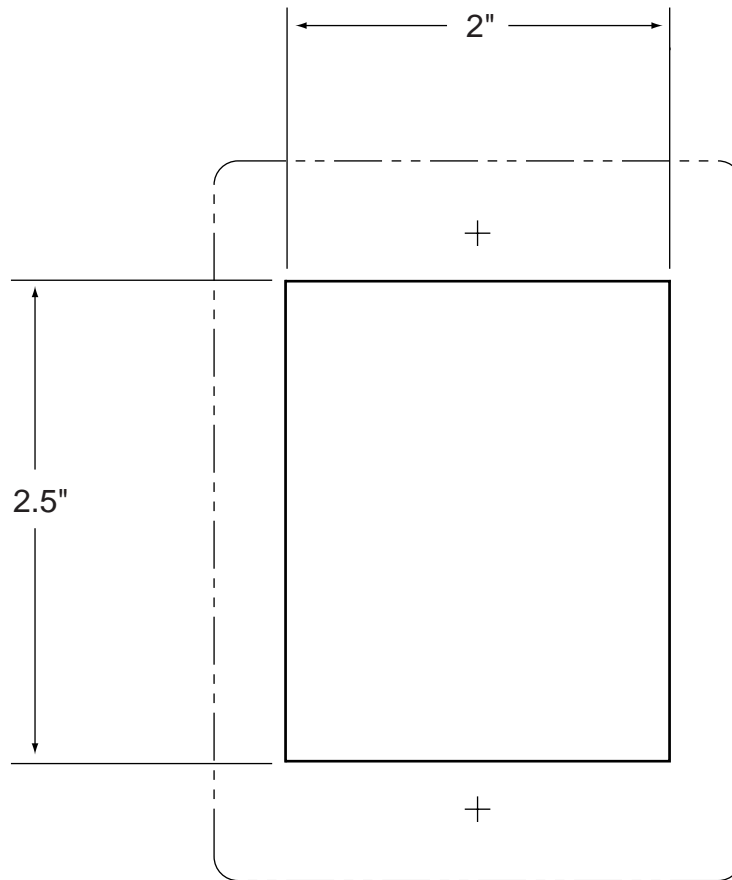

TracVision LF Owner's Manual Addendum



(ECO #6119)

The following information applies to Revision B of the TracVision LF Owner's Manual (KVH Part Number 54-0194).

A protective cover has been added to the switchplate to guard against damaging electrostatic discharges (ESD), which may occur during installation.

2.3 Connecting System Components

Figure 2-5 and the template on the following page have been changed to show the new switchplate cutout dimensions, which have been widened to accommodate the protective cover.

Figure 2-7 shows the switchplate connectors as they appear within the new cover.

Figure 2-5
Switchplate Cutout Dimensions

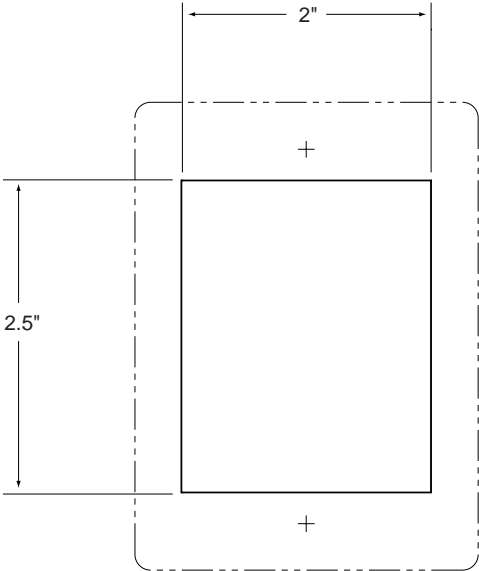
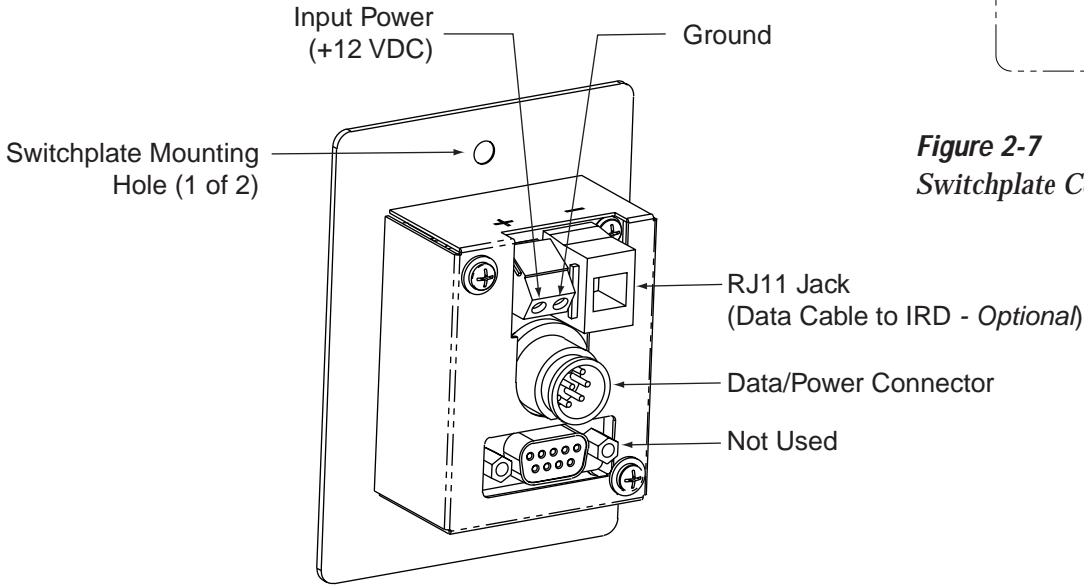
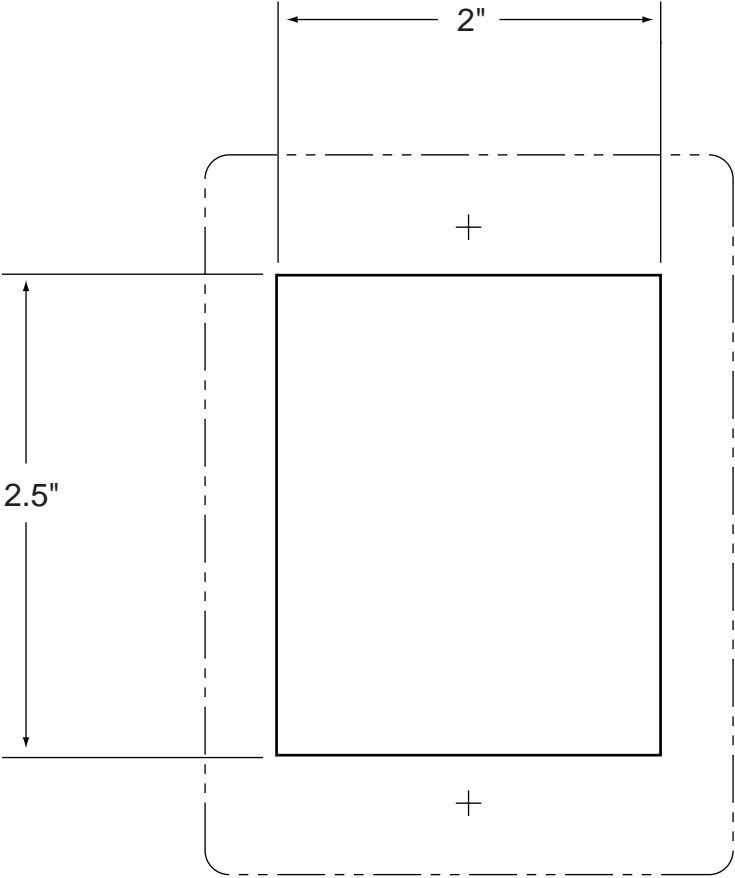

Figure 2-7
Switchplate Connectors



Appendix C

Switchplate Template



Congratulations!

You have selected one of the most advanced land-mobile satellite tracking systems available today. KVH® Industries' TracVision® LF is designed for use with DIRECTV®, DISH Network™, and ExpressVu. This manual provides detailed instructions on the proper installation, use, and maintenance of your TracVision LF system.

Throughout this manual, important information is marked for your attention by these icons:



A helpful tip that either directs you to a related area within the manual or offers suggestions on getting the highest quality out of your system.



An alert to important information regarding procedures, product specifications, or product use.



Information about installation, maintenance, troubleshooting, or other mechanical issues.



An electrical safety warning to help identify electrical issues that can be a hazard to either this KVH product or a user.



TracVision LF Serial Number



This serial number will be required for all troubleshooting or service calls made regarding this product.

Direct questions, comments, or suggestions to:

KVH Industries, Inc.

50 Enterprise Center
Middletown, RI 02842 USA
Tel: +1 401 847-3327
Fax: +1 401 849-0045
E-mail: info@kvh.com
Internet: www.kvh.com

[Click here to go to our state-of-the-art Customer Support web page...the fastest and easiest way to get all of your questions answered!](#)

If you have any comments regarding this manual, please e-mail them to manuals@kvh.com. Your input is greatly appreciated!



KVH Part # 54-0194 Rev. B
© 2002, KVH Industries, Inc.



TracVision® and KVH® are registered trademarks of
KVH Industries, Inc.

DIRECTV® is an official trademark of DIRECTV,
a unit of GM Hughes Electronics Corporation.

DISH Network™ is an official trademark of
EchoStar Communications Corporation.

ExpressVu is a property of Bell ExpressVu, a wholly owned
subsidiary of Bell Satellite Services.

Table of Contents

- 1 Introduction 1-1**
- 1.1 Digital Satellite Television 1-1**
- 1.2 TracVision LF System Overview 1-1**
 - 1.2.1 TracVision LF Components 1-2
 - 1.2.2 Integrated Receiver Decoder (IRD) 1-2
- 1.3 Materials Provided with TracVision LF 1-2**
 - 1.3.1 Additional Materials Required for TracVision LF Use 1-3

- 2 Installation 2-1**
- 2.1 Choosing the Best Location 2-2**
- 2.2 Mounting the Antenna Unit 2-3**
- 2.3 Connecting System Components 2-5**
 - 2.3.1 Connecting the Antenna to the Switchplate 2-6
 - 2.3.2 Connecting the Antenna to the IRD 2-6
 - 2.3.3 Sealing the Cable Access Hole 2-8
 - 2.3.4 Connecting the Switchplate to the IRD 2-8
 - 2.3.5 Connecting the Switchplate to Vehicle Power 2-9
 - 2.3.6 Connecting the IRD Ground Wire 2-9
 - 2.3.7 Installing the Switchplate 2-9
- 2.4 Activating the IRD 2-10**
- 2.5 Checking Out the System 2-10**
 - 2.5.1 Checking Out the System Using an IRD Data Connection 2-10
 - 2.5.2 Checking Out the System Without an IRD Data Connection 2-12
- 2.6 Configuring TracVision LF for Remote Satellite Dish Operation 2-13**

- 3 Using Your TracVision LF 3-1**
- 3.1 Turning On the System 3-1**
- 3.2 Tracking the Correct Satellite 3-3**

3.2.1	Using the IRD for Satellite Selection	3-3
3.2.2	Using the Switchplate for Satellite Selection	3-3
3.2.2.1	The Status Indicator	3-3
3.3	Turning Off the System	3-4
3.4	Watching Television	3-4
4	Troubleshooting	4-1
4.1	Causes and Remedies for Common Operational Issues	4-1
4.1.1	Blown Fuse or Improper Wiring	4-2
4.1.2	Dew or Rain Pooling on Dome	4-2
4.1.3	Satellite Signal Blocked	4-2
4.1.4	Satellite Coverage Issue	4-3
4.1.5	Vehicle Turning During Startup	4-3
4.1.6	Incorrect or Loose RF Connectors	4-3
4.1.7	Type of Multiswitch Used	4-3
4.2	IRD Troubleshooting	4-4
4.2.1	IRD Wiring	4-4
4.2.2	AC Power Fluctuating	4-4
4.2.3	No IRD Data Connection	4-4
4.2.4	EchoStar IRD Activation Check	4-4
4.2.5	Failed IRD Status Check	4-5
4.2.6	IRD Faulty	4-5
4.3	Antenna Gyro and LNB Faults	4-6
4.4	Computer Diagnostics	4-6
4.5	Maintenance Port Parser Commands	4-7
5	Maintenance	5-1
5.1	Warranty/Service Information	5-1
5.2	Preventive Maintenance	5-1
5.3	Replaceable Parts	5-2
5.4	Field Replaceable Unit Procedures	5-3
5.4.1	PCB Removal and Replacement	5-5

5.4.2	Antenna Gyro Assembly.....	5-6
5.4.3	Antenna LNB Replacement.....	5-8
5.5	Preparation for Shipment	5-10
Appendix A	System Specifications	A-1
Appendix B	Comprehensive TracVision LF System Wiring Diagram	B-1
Appendix C	Switchplate Template	C-1
Appendix D	EchoStar IRD Activation Procedure	D-1
Appendix E	Startup Data Sequences	E-1
E.1	System Connected to IRD Data	E-1
E.2	System Not Connected to IRD Data	E-3
Appendix F	Maintenance Port Parser Commands	F-1
F.1	System Commands	F-1
F.2	Manual Positioning Commands	F-2
F.3	Operational Commands	F-3
F.4	Target and Signal Commands	F-4

List of Figures

Figure 1-1	TracVision LF System Configuration	1-1
Figure 2-1	Antenna Blockage	2-2
Figure 2-2	Maximum Mounting Surface Slope	2-2
Figure 2-3	Removing the Shipping Restraint	2-3
Figure 2-4	Proper Orientation of the Antenna Unit	2-3
Figure 2-5	Switchplate Cutout Dimensions	2-5
Figure 2-6	Antenna Baseplate Connectors	2-5
Figure 2-7	Switchplate Connectors	2-6
Figure 2-8	Installing Three or Four IRDs Using an Active Multiswitch	2-7
Figure 2-9	Installing the Clamshell Ventilator	2-8

Figure 2-10	Maintenance Connector	2-12
Figure 2-11	PC Data Cable DB9 Connector	2-12
Figure 2-12	Remote Dish Wiring Configuration	2-13
Figure 3-1	Be Aware of Objects that Might Block the Satellite Signals	3-1
Figure 3-2	Switchplate Front Panel	3-2
Figure 4-1	Maintenance Connector	4-6
Figure 4-2	PC Data Cable DB9 Connector	4-6
Figure 5-1	Antenna, PCB, and Rotating Plate	5-3
Figure 5-2	Close-up of Connecting Rod and E-ring	5-3
Figure 5-3	Antenna Assembly	5-4
Figure 5-4	Rotating Plate	5-4
Figure 5-5	Removing the PCB Cover	5-5
Figure 5-6	PCB Connector Locations – Rear View	5-6
Figure 5-7	Baseplate Shipping Restraint Holes	5-10
Figure 5-8	Attaching the Shipping Restraint	5-10

List of Tables

Table 1-1	TracVision LF Packing List	1-2
Table 2-1	Installation Process	2-1
Table 2-2	Kitpack Contents	2-1
Table 2-3	TracVision LF Operational Messages	2-11
Table 2-4	DIRECTV On-screen Messages	2-11
Table 3-1	Status Indicator Conditions	3-3
Table 4-1	Troubleshooting Matrix	4-1
Table 5-1	Field Replaceable Units	5-2
Table A-1	TracVision LF System Specifications	A-1
Table F-1	System Commands	F-1
Table F-2	Manual Positioning Commands	F-2
Table F-3	Operational Commands	F-3
Table F-4	Target and Signal Commands	F-4

1 Introduction

1.1 Digital Satellite Television

DIRECTV®, DISH Network™, and ExpressVu systems transmit digital audio and video data from land-based transmitters to a satellite “parked” above the equator. Each satellite relays the signals in spot beams covering the continental United States and contiguous waters. TracVision LF automatically identifies, locks onto, and tracks signals from the appropriate satellite, both while your vehicle is at rest and in motion.

1.2 TracVision LF System Overview

A complete satellite TV system includes the TracVision LF connected to an IRD (satellite TV receiver) and a television set. A desktop or laptop computer is used to conduct diagnostics. The complete system is illustrated in Figure 1-1. System specifications and a wiring diagram are provided in *Appendices A* and *B*, respectively.

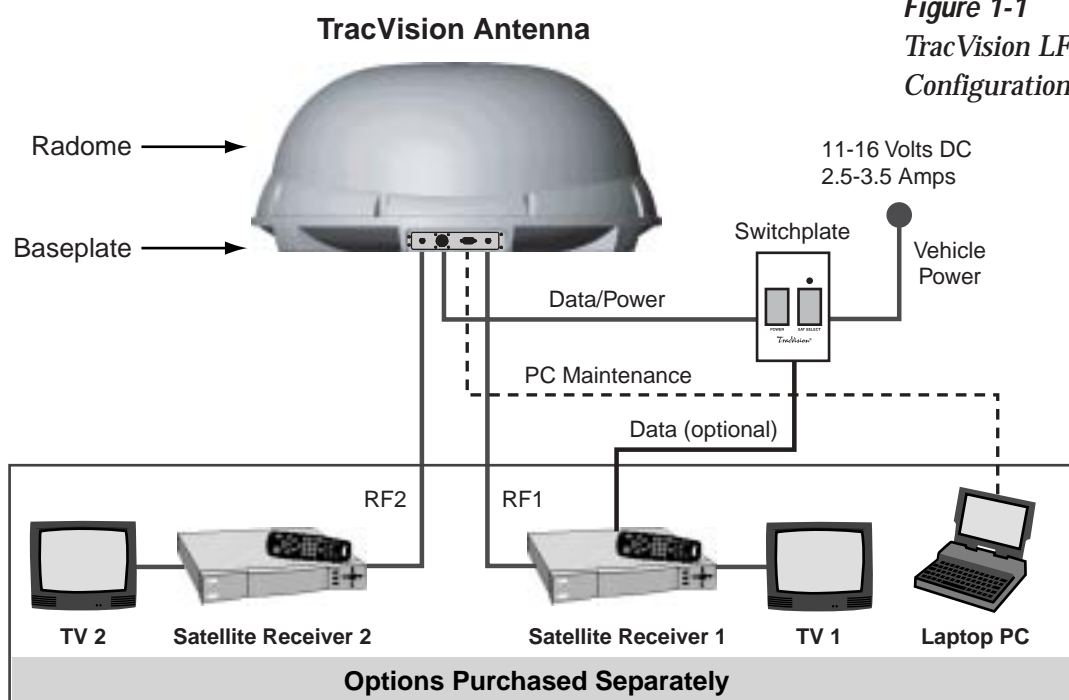

Figure 1-1
TracVision LF System
Configuration

1.2.1 TracVision LF Components

The antenna unit includes the antenna positioning mechanism, signal front end, power supply and control elements. These elements include antenna drive controls and mechanisms, the cable wrap subassembly, antenna gyro sensor, power conditioning and regulating circuits, and the RF detector. The antenna is a parabolic dish mounting a dual-output low noise block (LNB) converter with built-in preamplifier. A molded ABS radome encloses the baseplate and is secured in place with standard fasteners. Connectors on the back of the baseplate join the power, signal, and control cabling from units inside the vehicle.



On-screen messages are not available with a DISH Network IRD.

1.2.2 Integrated Receiver/Decoder (IRD)

The IRD (purchased separately) receives satellite signals from the antenna unit for signal decoding, processing, and channel selection, and sends the signals to the TV set for viewing. In addition, messages can be sent from the IRD to the antenna unit and messages can be received from the antenna unit for display on the television screen. The IRD also provides the interface for the user to activate authorization for reception. Please refer to the User's Manual provided with your selected IRD for complete operating instructions.

1.3 Materials Provided with TracVision LF

Table 1-1 lists the units, cables, and materials packed in the TracVision LF package by name and KVH part number.

Table 1-1
TracVision LF Packing List



Cables for the TracVision LF are stored beneath the antenna unit during shipping.

Component	KVH Part No.
Antenna Unit	01-0225-15
RF Cable (28 ft)*	32-0417-28
Data/Power Cable (28 ft)*	32-0731-28
Kitpack**	72-0120
Installation and Operation Manual	54-0194

* RF and data/power cables may be supplied separately.

** A complete listing of kitpack contents is provided in [Table 2-2](#).

1.3.1 Additional Materials Required for TracVision LF Use

To make full use of your new TracVision LF and receive satellite TV, you will need to provide/purchase the following:

- Television
- Appropriate IRD for your selected satellite TV service



You can purchase and activate an IRD directly from KVH! Call KVH at 1-888-584-4163 for details.

2 Installation

TracVision LF is designed for simple installation and setup. Just follow these easy steps:

Step	Refer to Section...
1. Choose the antenna location	2.1
2. Mount the antenna unit	2.2
3. Connect the system components	2.3
4. Activate the IRD	2.4
5. Check out the system	2.5

Tools and Materials Required

- Electric drill
- $\frac{3}{16}$ "-drill bit and $\frac{3}{4}$ " hole saw and auger bit
- #2 Phillips and #0 flat tip screwdrivers
- Silicone sealant or RTV
- $\frac{7}{16}$ "-open end wrench
- Adhesive suitable for specific roof construction and materials (e.g., Liquid Nails)
- Rivet gun and $\frac{3}{16}$ "-rivets (or other fastener suitable for specific roof construction)
- *(Recommended)* PC with terminal emulation software such as PROCOMM or Windows Terminal or Hyperterminal and a DB9 (male-to-female) PC data cable

Kitpack Contents

Table 2-2 lists the materials provided in the kitpack.

Part	Qty.	KVH Part No.
Switchplate Assembly	1	02-1236-01
Tie-wraps	5	22-0013
$\frac{3}{8}$ " Hole Plugs	2	19-0282-06
RJ11 Handset Cable	1	32-0724-25
Clam Shell Ventilator	1	19-0230
#6 x $\frac{3}{4}$ " Thread-forming Screws	5	14-0298-12
IRD Ground Wire (50 ft)	1	32-0583-50

Table 2-1
Installation Process



Plan the entire installation before proceeding! Take into account component placement, cable running distances between units, and accessibility to the equipment after installation.



While some DIRECTV IRDs offer on-screen messages, it is recommended that a PC be available for all installations of DIRECTV, EchoStar, and ExpressVu.

Table 2-2
Kitpack Contents

2.1 Choosing the Best Location

- Since the TracVision antenna requires a clear view of the southern sky to receive satellite signals, the ideal antenna site has an unobstructed view of the horizon/satellite all around.
- Keep the antenna clear of any obstructions on the roof (e.g., air conditioners). The antenna requires a 15° to 75° look angle to receive satellite signals.

Figure 2-1
Antenna Blockage

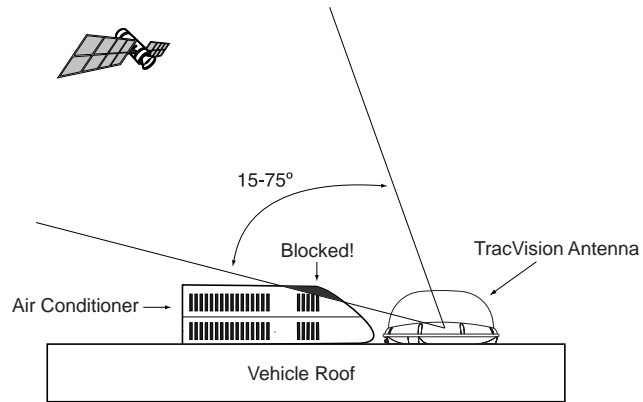

- Consider the location of the antenna relative to the location of any equipment or necessary wiring within the vehicle.
- Be sure to mount the antenna on a horizontal surface with a minimum roof (or other mounting surface) radius of 250". In other words, when placed flat on the mounting surface, the mounting plates should be less than $\frac{7}{16}$ " above the mounting surface (see Figure 2-2). **Any larger gap will warp the baseplate and seriously damage the antenna.**

Figure 2-2
Maximum Mounting Surface Slope

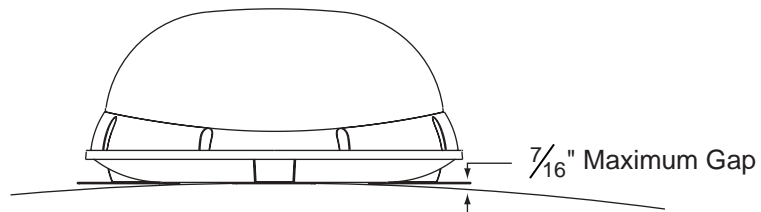

2.2 Mounting the Antenna Unit

1. Make sure that you have chosen a suitable mounting location based upon the guidelines in *Section 2.1, "Choosing the Best Location."*
2. Remove the antenna unit from its shipping carton.
3. At the bottom of the antenna baseplate, cut the tie-wrap and pull it out of the baseplate. Then seal the two holes with the plugs provided in the kitpack. The tie-wrap secures the antenna's LNB for shipping (as shown in Figure 2-3). **Once you remove this shipping restraint, be sure to handle the antenna unit with care to avoid damage.**

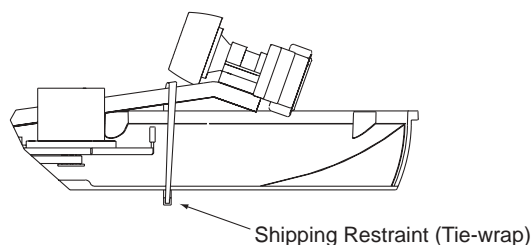

Always lift the antenna unit by the gray baseplate, never by the radome!

Figure 2-3
Removing the Shipping Restraint



Once you remove the shipping restraint, handle the antenna unit carefully. Improper handling may damage the unit.

4. Position the antenna unit in the desired location on the centerline of the vehicle with the antenna's forward mounting plate arrows facing the front of the vehicle. The proper orientation is illustrated in Figure 2-4.

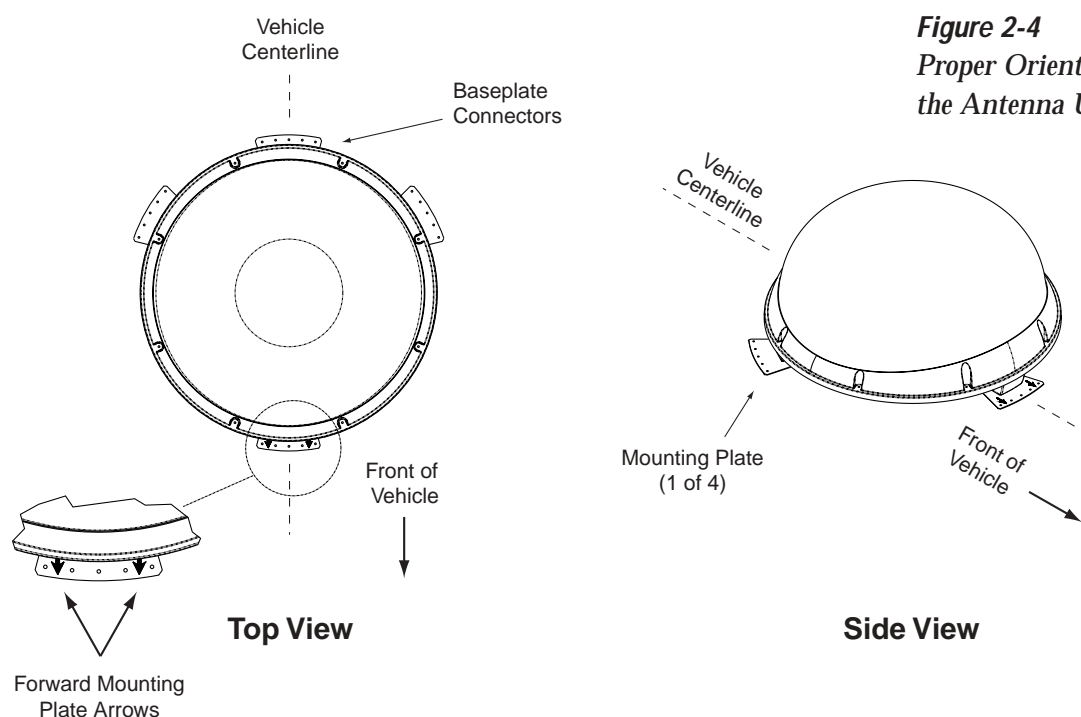

Figure 2-4
Proper Orientation of the Antenna Unit



If the roof's mounting surface is not perfectly flat as KVH recommends, make sure the baseplate does not warp when you attach the antenna's mounting plates. Refer to Section 2.1, "Choosing the Best Location," for further details.

5. Using the four mounting plates as templates, drill 20 $\frac{3}{16}$ " holes through the roof of the vehicle.
6. Apply construction adhesive to the bottom of the antenna's four mounting plates. If using a liquid construction adhesive, apply beads to the mounting plates in a zig-zag pattern.
7. Attach the mounting plates to the roof using $\frac{3}{16}$ "-diameter rivets (or appropriate fasteners). Seal all rivet heads and edges with silicone.
8. Mark a location on the roof for the cable access hole to permit convenient cable access to the antenna's baseplate connectors. Drill the $\frac{3}{4}$ " cable access hole in the vehicle's roof.

2.3 Connecting System Components

The following sections provide instructions for properly wiring the antenna unit to the components inside the vehicle.

Locating the Switchplate

Before running cables, you need to determine the location for the TracVision LF switchplate.

1. The switchplate should be installed in a dry, flat location within reach of the cables that will connect to the antenna unit.
2. Once you've decided on a suitable location, create a panel cutout in the mounting surface. Figure 2-5 illustrates the mounting dimensions and a full-size template has been provided in [Appendix C](#). All connecting cables will be routed through this cutout.

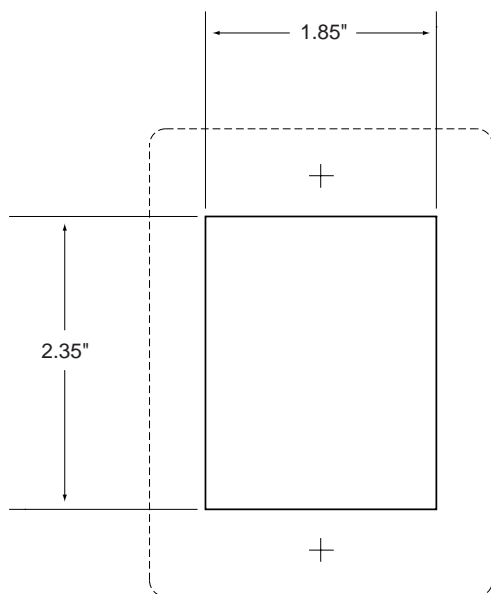

Figure 2-5
Switchplate Cutout Dimensions

Figure 2-6 shows the antenna unit's baseplate connectors. [Figure 2-7](#) on the following page shows the switchplate's connectors. Refer to these figures when connecting cables to the antenna unit and the switchplate.

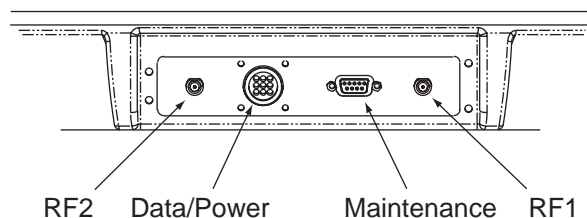
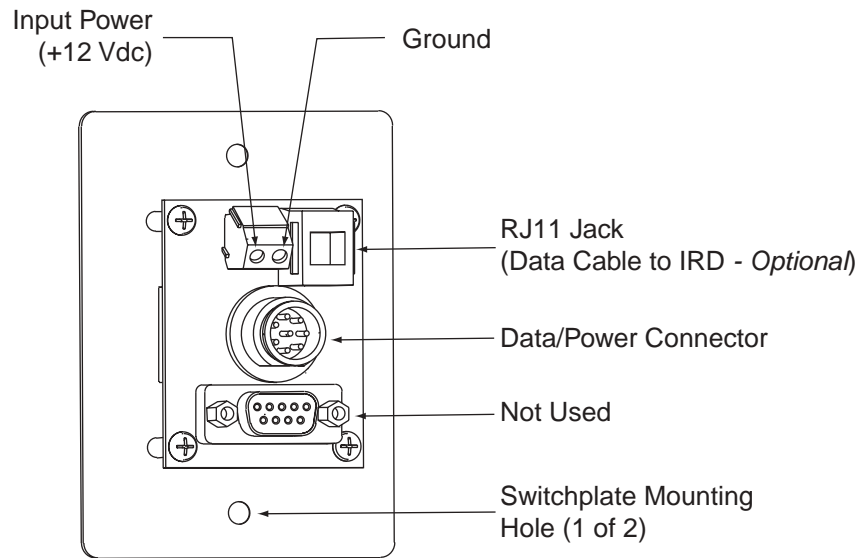

Figure 2-6
Antenna Baseplate Connectors

Figure 2-7
Switchplate Connectors



2.3.1 Connecting the Antenna to the Switchplate

1. Connect the threaded connector end of the antenna data/power cable to the antenna's data/power connector and tighten until locked in place (see [Figure 2-6](#)).
2. Route the other end of the data/power cable down through the cable access hole in the vehicle's roof and out through the switchplate panel cutout.
3. Connect the data/power cable to the switchplate's data/power connector and lock in place (see [Figure 2-7](#)).



KVH recommends the use of RG-6 or RG-11 (75 ohms) cable for RF wiring. Use of non-RG-6 or RG-11 (75 ohms) cables will result in degraded performance. The KVH warranty does not cover degraded performance due to improper wiring.



When shipped from the factory, the antenna's RF connectors are protected with caps. Leave the cap installed on the RF2 connector unless you are going to connect a second RF cable to the TracVision LF.

2.3.2 Connecting the Antenna to the IRD

1. Route an RF cable up through the roof's cable access hole.
2. Connect the RF cable to the antenna's RF1 connector (see [Figure 2-6](#)). Once the cable is securely connected, loosen the sealing nut at the base of the RF1 connector and tighten it onto the end of the RF cable.
3. Connect the other end of the RF cable to the IRD's SATELLITE IN connector.

Installing Two IRDs and TVs

To connect a second TV and IRD to the TracVision LF system, you must connect a second RF cable to the antenna's RF2 connector (see [Figure 2-6](#)). Route the other end of the RF cable down into the vehicle and connect it directly to the second IRD.

Connecting Three or More IRDs and TVs

To install three or more IRD/TV pairs, an active multiswitch (Channel Master model 6214IFD or equivalent) must be placed between the antenna unit and the IRDs. [Figure 2-8](#) illustrates typical wiring arrangements for multiple IRDs. If more than four IRDs are required, contact KVH for additional wiring instructions. Mount the multiswitch unit in accordance with the manufacturer's instruction sheet.

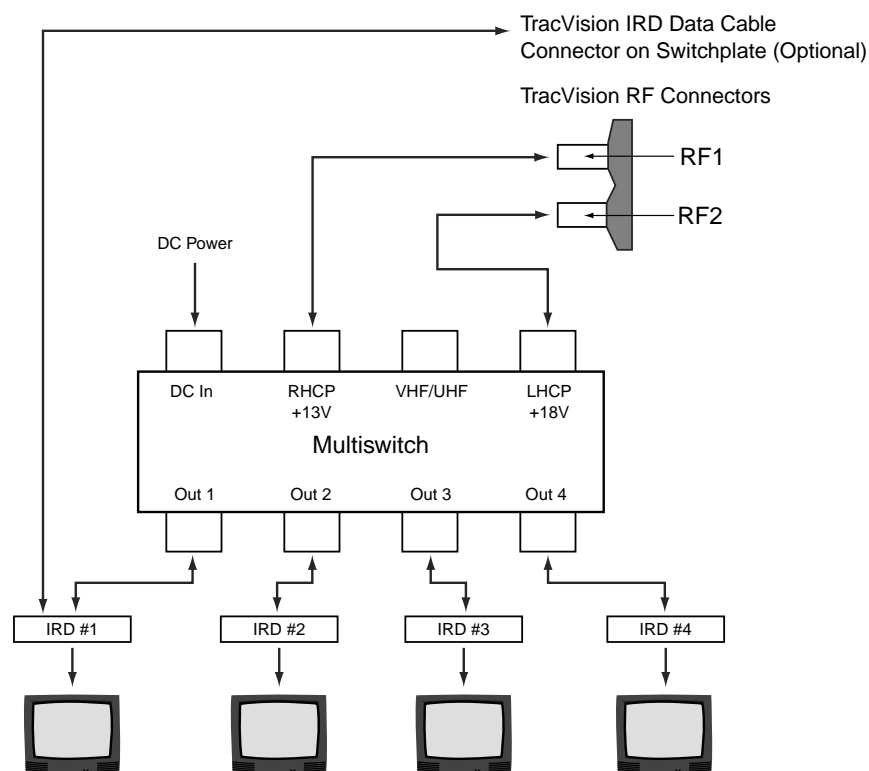

Figure 2-8
Installing Three or Four IRDs
Using an Active Multiswitch



If you are connecting multiple IRDs, attach the data cable to the master IRD. The master IRD must remain on for the secondary IRDs to function properly.

1. Connect the RF cable tagged "RF1" to the multiswitch input labeled "LNB RHCP +13V."
2. Connect a second RF cable to the multiswitch input labeled "LNB LHCP +18V."
3. Connect the multiswitch outputs to individual IRD inputs. Use RG-6 cable terminated with F-type connectors for all RF connections.

4. Terminate all unused output connectors with 75 ohm DC blocks (Channel Master #7184, Radio Shack #15-1259 or equivalent).

2.3.3 Sealing the Cable Access Hole

Once the RF and data/power cables are connected to the antenna, you need to seal and cover the cable access hole to protect against leakage.

1. Completely seal the cable access hole with silicone sealant or RTV.
2. Install the clamshell ventilator, supplied in the kitpack, over the cable access hole using three of the supplied #6 screws (see Figure 2-9).

Figure 2-9
Installing the Clamshell Ventilator

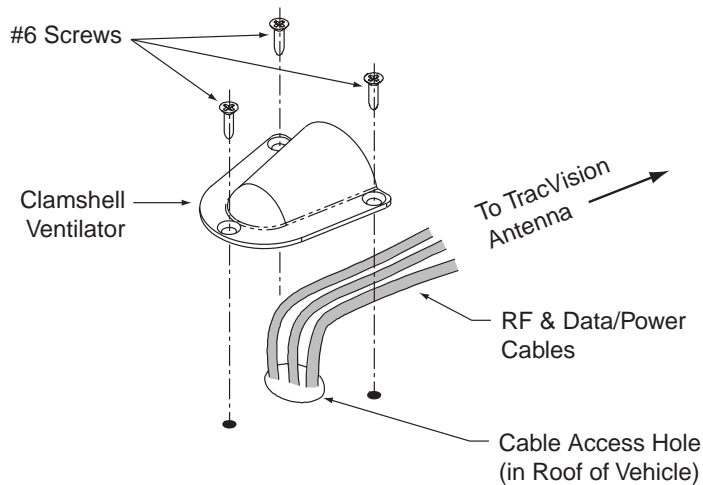

EchoStar IRDs cannot be connected to the switchplate due to incompatibility. Satellite selection must be done manually through the switchplate's SAT SELECT button.

2.3.4 Connecting the Switchplate to the IRD (Optional)

The switchplate includes an RJ11 jack for connecting the system to an IRD's low-speed data port. This allows a compatible DIRECTV IRD to communicate with the antenna for automatic satellite selection. Without this data connection, you will need to manually select the satellite using the switchplate's SAT SELECT button (see [Section 3.2, "Tracking the Correct Satellite"](#) for details).

1. Connect one end of the supplied data cable (a standard RJ11 telephone handset cord) to the switchplate's RJ11 jack (see [Figure 2-7](#)).
2. Route the other end of the data cable to the IRD and connect it to the IRD's low-speed data port.

2.3.5 Connecting the Switchplate to Vehicle Power

The switchplate must be connected to a +12 Vdc, 2.5-3.5 amp power supply to operate.

1. Disconnect vehicle power by removing the appropriate vehicle fuse.
2. Run a cable from vehicle's power (11-16 Vdc) out through the panel cutout.
3. Connect the power cable to the switchplate's power terminals as shown in [Figure 2-7](#).



Before connecting the antenna unit to vehicle power, remove the appropriate vehicle fuse to prevent a short circuit. Replace the fuse after the connection to vehicle power is complete.

2.3.6 Connecting the IRD Ground Wire

A grounding wire has been provided to connect your IRD to a suitable ground and protect the system. Attach the grounding wire to any suitable screw on the rear panel of the IRD with a good contact with the IRD chassis. The other end should be connected to a suitable ground, ideally the ground connector on the switchplate (see [Figure 2-7](#)).

2.3.7 Installing the Switchplate

After completing the switchplate wiring, you need to install the switchplate itself.

1. Carefully fit the switchplate assembly into the panel cutout (made in Step 2 of [Section 2.3, "Connecting System Components"](#)) until the switchplate is flush to the mounting surface.
2. Secure the switchplate to the mounting surface using the two supplied #6 thread-forming screws.
3. Reinstall the vehicle fuse removed in Step 1 of [Section 2.3.5, "Connecting the Switchplate to Vehicle Power."](#)

2.4 Activating the IRD

KVH makes it easy to activate your IRD. Just call KVH at 1-888-584-4163 and ask for **IRD Activation** (Monday - Friday, 8:30 a.m. - 5:00 p.m. EST). For other options, please refer to the user manual that accompanied your IRD.

Note that EchoStar IRDs that have not been activated within several months of manufacture require additional steps to complete the process. Refer to [Appendix D](#) for complete details.



*If a need arises to paint the radome, **ONLY use non-metallic automotive paint** to avoid degrading the RF signal strength and the reception quality.*

2.5 Checking Out the System

If the system is connected to an IRD's low-speed data port (via an RJ11 cable from the switchplate), follow the procedure in [Section 2.5.1, "Checking Out the System Using an IRD Data Connection."](#) If the system is not connected to an IRD's low-speed data port, follow the procedure in [Section 2.5.2, "Checking Out the System Without an IRD Data Connection."](#)

2.5.1 Checking Out the System Using an IRD Data Connection

Turn on the IRD and press the switchplate's POWER button to power up the TracVision LF system. Observe messages on your TV screen to verify proper operation. Some messages originate in the IRD, others are generated in the TracVision LF circuits.



All IRDs are susceptible to AC power fluctuations that can result in the IRD locking up and requiring a reset. Refer to [Section 4.2, "IRD Troubleshooting,"](#) for a solution to this issue.

Depending on your choice of satellite TV service and IRD, the system may display several text messages on the television screen to aid in monitoring TracVision LF performance. These messages are not displayed when the IRD is displaying the Signal Strength Meter on the TV screen. The messages and their meanings are described in Table 2-3 on the following page.

Message	Definition
KVH TracVision LF	Displays for 5 seconds at startup
Software Version	Current software version Alternates with "KVH TracVision LF"
Initializing	System initializing
Search Mode 1	Antenna Unit in Search Mode 1
Search Mode 2	Antenna Unit in Search Mode 2
Search Mode 3	Antenna Unit in Search Mode 3
Reacquisition	System is reacquiring the satellite
RF Signal Error	RF signal detector has no signal at input
AZ Motor Error	Fault detected in azimuth drive subassembly
EL Motor Error	Fault detected in elevation drive subassembly
Ant Gyro Error	Fault detected in antenna gyro assembly, OR antenna gyro failed to initialize properly because vehicle was turning during the 60-second startup and initialization period following power-up
Cable Unwrap	System in process of unwrapping cable

Differences among IRD low-speed data ports may result in different message formats, and some messages may not be displayed on the television screen. DIRECTV messages you may see are listed in Table 2-4.

Message	Definition
Searching for satellite – please stand by	The IRD is powered up and doesn't detect the satellite signal.
Searching for program guide – please stand by	The system has found the satellite, but has been turned off for more than approximately four hours. This message appears for about 10 seconds.

Refer to your DIRECTV User's Manual for specific messages displayed by your system.

Table 2-3
*TracVision LF Operational
Messages*



The DISH Network and some newer IRDs (e.g., the Sony A50) give priority to internal IRD messages rather than on-screen messages. KVH recommends that the maintenance port be used to read installation-related messages on a PC (see Section 2.5.2, "Checking Out the System Without an IRD Data Connection").

Table 2-4
DIRECTV On-screen Messages

2.5.2 Checking Out the System Without an IRD Data Connection

To ensure that the system is configured and operating properly, you will need to check the data provided in the system's startup routine.

To do so, you need to connect a PC to the antenna baseplate's maintenance port. The diagnostics procedure requires terminal emulation software such as PROCOMM or Windows Terminal or Hyperterminal. Use the settings appropriate to your application.

1. Connect one end of a PC data cable to the maintenance connector on the antenna baseplate (see Figure 2-10). Connect the other end to the serial port on the PC (a 9-pin/25-pin connector adapter may be needed for some PCs).

Figure 2-10
Maintenance Connector

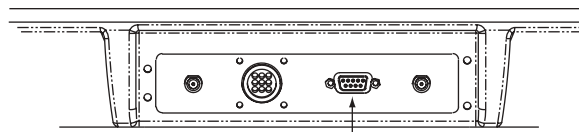

Maintenance Connector

Figure 2-11
PC Data Cable DB9 Connector

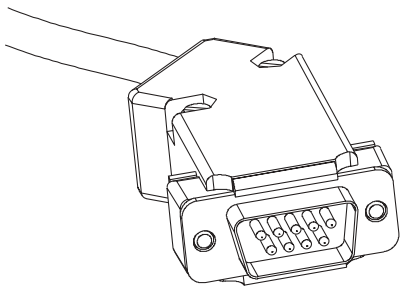

2. Open the terminal emulation software and establish the following settings:
 - 9600 baud
 - no parity
 - 8 data bits
 - 1 start bit
 - 1 stop bit
 - no flow control
3. Press the switchplate's POWER button to apply power to the TracVision LF system and wait for the system to fully initialize. Data should be scrolling on the PC display to identify any system problems detected. If no data is seen, recheck your connections and the terminal software setup.
4. After completing the review of the startup and operational routines, shut down the system.

2.6 Configuring TracVision LF for Remote Satellite Dish Operation

In some campground locations, dense foliage will block the satellite signal. In these situations, a remote portable antenna may be the only solution to satellite signal reception.

The wiring option for the remote dish is very simple and should be installed when the TracVision LF is installed. A high-quality “A/B switch” should be used to change from TracVision to remote antenna operation. The recommended wiring arrangement for remote dish operation is illustrated in Figure 2-12.

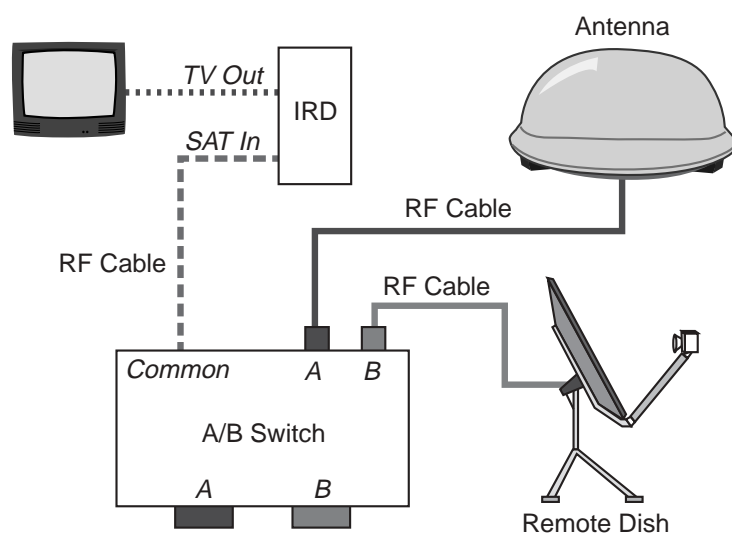

Figure 2-12
Remote Dish Wiring Configuration

3 Using Your TracVision LF

For TracVision LF to receive the satellite signals, the antenna must have a clear line of sight to the satellite. If you only receive intermittent signals or the antenna cannot find the satellite, check around your vehicle for any objects that could be blocking the signal, such as trees, buildings, highway overpasses, etc.



Figure 3-1

Be Aware of Objects that Might Block the Satellite Signals

You must also be located within the selected satellite's coverage area in order to receive its signal. Refer to your satellite television service manual to check the viable coverage area. *For your convenience, KVH provides links to several web sites that offer satellite coverage information. Simply go to our web site at: www.kvh.com/footprint/index.html.*

3.1 Turning On the System

The TracVision LF system is easy to use. To turn on the TracVision LF system, follow the steps below.

1. Turn on the IRD and the television. (Refer to your IRD user manual for complete operating instructions for the IRD.)
2. Press the switchplate's POWER button, as pictured in [Figure 3-2](#) on the following page.

Figure 3-2
Switchplate Front Panel

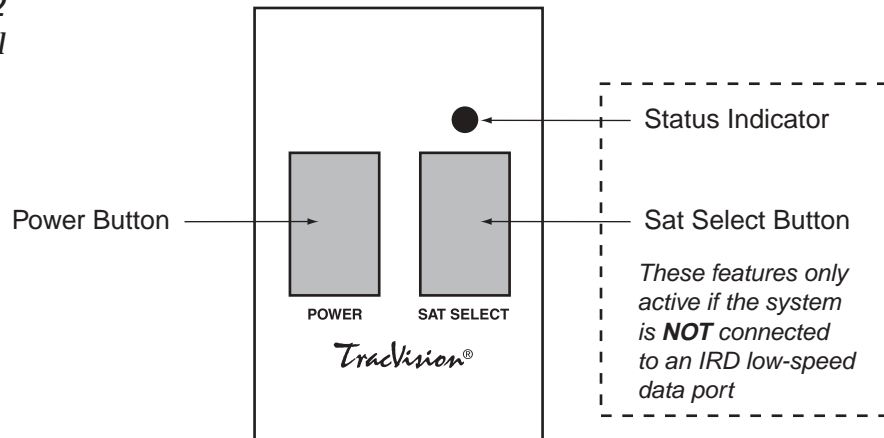

If Connected to an IRD Low-speed Data Port:

As part of the startup process, the TracVision LF system will default to Channel 200, a program directory. This is the system's means of verifying that it has identified and is tracking the correct satellite.

Once Channel 200 appears, wait at least another 30 seconds before changing the channel to ensure that the system has completed its startup routine.

3. Avoid turning for 60 seconds after turning on the antenna to allow the antenna gyro to initialize properly.

System Startup (Connected to an IRD Low-speed Data Port)

1. Upon power-up, the system performs a set of startup routines.
2. The antenna then searches for a TV satellite.
3. Once the antenna finds a satellite, it uses the IRD data connection to determine if the satellite signal can be decoded. If the signal can be decoded by the IRD, the antenna locks onto and tracks the satellite.

System Startup (Not Connected to an IRD Low-speed Data Port)

1. Upon power-up, the system performs a set of startup routines. If any errors are detected, the Status indicator flashes quickly (3-4 times per second).
2. The antenna then searches for a TV satellite. During this search, the Status indicator flashes slowly (1-2 times per second).
3. Once the antenna finds and starts tracking a satellite, the Status indicator comes on solid.
4. If your TV does not show a clear picture, the antenna is tracking the wrong satellite. Refer to [Section 3.2.2, "Using the Switchplate for Satellite Selection"](#) for instructions on selecting a different satellite.

3.2 Tracking the Correct Satellite

If your system is connected to an IRD's low-speed data port, follow the steps in [Section 3.2.1, "Using the IRD for Satellite Selection."](#) If your system is not connected to an IRD's low-speed data port, follow the steps in [Section 3.2.2, "Using the Switchplate for Satellite Selection."](#)

3.2.1 Using the IRD for Satellite Selection

If your TracVision LF is connected to an IRD's low-speed data port, the antenna will automatically find and track the correct satellite based on the information it receives from the IRD. No user interaction is required.

3.2.2 Using the Switchplate for Satellite Selection

If your system is not connected to an IRD's low-speed data port, you will need to use the switchplate to manually find your satellite.

1. Press the switchplate's SAT SELECT button.
2. The Status indicator flashes while the antenna searches for a satellite signal. Once the antenna finds and starts tracking a satellite, the Status indicator stops flashing.
3. If your TV shows a clear picture, you are tracking the correct satellite. If no picture appears, repeat this procedure starting with Step 1.



If your antenna is unable to find the desired satellite, refer to [Section 4, "Troubleshooting"](#) for possible causes and their corrective actions.

3.2.2.1 The Status Indicator

If your system is **not** connected to an IRD's low-speed data port, the switchplate's Status LED indicates the antenna's current condition. Table 3-1 describes this LED's four conditions.

LED Condition	Meaning
OFF	Initializing, please wait
ON	Tracking a satellite
Slow Flashing	Searching for a satellite, please wait
Fast Flashing	System error, see Section 4, "Troubleshooting"

Table 3-1
Status Indicator Conditions

3.3 Turning Off the System

To turn off the TracVision LF system, simply press the switchplate's POWER button (see [Figure 3-2](#)).

3.4 Watching Television

TracVision LF is designed to operate as efficiently and as reliably as possible whether your vehicle is in motion or parked.



Don't forget to turn the system back on before you start driving again. The antenna must be turned on to track the satellite while you are moving.

Using Your TracVision LF When Parked

When your vehicle is stopped, it is not necessary for the TracVision LF to be turned on. After parking your vehicle and confirming that the antenna is receiving the satellite signal, you may turn off the TracVision LF unit to avoid unnecessary use of power. The antenna will continue to receive the satellite TV signals and relay them to the IRD.

DISH 500 Subscribers

The DISH 500 service offers programming on two different satellites. As a result, if you change to a channel that is located on the other satellite, you will need to use the switchplate's SAT SELECT switch to select the second satellite. Further, if you then need to switch back to the first satellite, you will need to use the SAT SELECT switch again until the first satellite is reacquired. Please be patient during this process; due to the satellites' spacing, it may take some time to return to the original satellite.

Cable Unwrap

The Antenna Unit can rotate a full 720° before coming to the end of its cable. If it does so, the system automatically unwraps the cable by quickly rotating the dish in the opposite direction. During this process, your television transmission will be frozen momentarily while the cable unwraps and the antenna reacquires the satellite.

Conical Scan Tracking

The antenna control unit uses conical scanning to maintain peak signal strength to the receiver and to update the satellite's position. When conical scan tracking is active, the antenna moves continually with a circular motion to sweep across the satellite's peak signal. The signal strength is then fed back to the control circuits to keep coming back to the direction of the strongest signal.

If the satellite signal is lost while the system is in conical scan track mode, the control software imposes a 60-second time-out delay. If the signal is not regained during that time, the antenna reverts to the Reacquisition Search to start looking for the satellite signal.

4 Troubleshooting

The troubleshooting matrix shown in Table 4-1 identifies some trouble symptoms, their possible causes, and references to troubleshooting solutions.

Table 4-1
Troubleshooting Matrix

SYMPTOM	POSSIBLE CAUSE (AND SOLUTION)														
	Blown fuse or improper wiring (Section 4.1.1)	Dew or rain pooling on dome (Section 4.1.1)	Satellite signal blocked (Section 4.1.2)	Satellite coverage issue (Section 4.1.3)	Vehicle turning during startup (Section 4.1.4)	Incorrect or loose RF connectors (Section 4.1.5)	Type of multiswitch used (Section 4.1.6)	IRD wiring (Section 4.1.7)	AC power fluctuating (Section 4.1.7)	No IRD data connection (Section 4.2.2)	EchoStar IRD activation (Section 4.2.3)	Failed IRD status check (Section 4.2.4)	IRD faulty (Section 4.2.5)	Antenna gyro faulty (Section 4.3)	LNB assembly faulty (Section 4.3)
Antenna non-functional	X														
No IRD status message							X	X	X		X	X			
No picture on TV set			X		X	X		X			X	X			X
Intermittent picture for short intervals		X	X	X	X	X	X	X				X	X	X	
System will not find satellite		X	X	X	X	X		X		X	X	X			X
Snowy television picture												X			
IRD locks up								X			X				
Picture jumbled, parts missing, freezing	X		X												
Switchplate status indicator flashing fast					X			X					X	X	
System works at rest but not on the move		X											X		

4.1 Causes and Remedies for Common Operational Issues

There are a number of common issues that can affect the signal reception quality or the operation of the TracVision LF. The following sections address these issues and potential solutions.

4.1.1 Blown Fuse or Improper Wiring

If the antenna unit is installed but entirely non-responsive, there are two key factors to check as part of the troubleshooting process:

1. Blown Fuse – The antenna unit is equipped with a fuse mounted on its CPU Board. If this fuse has blown or been broken, the antenna unit will not operate. Refer to *Section 5.4.1, “PCB Removal and Replacement,”* for details on the fuse location and how to access the CPU Board.
2. Wiring – If the system has been improperly wired, the antenna unit will not operate correctly. Refer to *Section 2.3, “Connecting System Components”* for complete system wiring information.

4.1.2 Dew or Rain Pooling on Dome

Dew or rain can occasionally pool on the top of the radome. While this moisture will usually be dispersed when the vehicle is in motion, it can disrupt the signal while the vehicle is at rest. This issue can be minimized with two approaches:

1. Using a hose, spray the dome with water to remove the dew from the dome surface.
2. Periodically apply liquid dish detergent to the dome surface. Wipe the full-strength detergent on the dome and allow it to dry. This treatment will provide a film that will help moisture bead up and roll off the dome.

4.1.3 Satellite Signal Blocked

Satellite signals can be blocked or degraded by trees and branches, buildings, overpasses, mountains, or equipment on the vehicle itself. Refer to *Section 2.1, “Choosing the Best Location,”* to make certain that the TracVision LF unit is in the optimal location. Simply moving the vehicle to clear an external obstruction will also restore signal quality.

4.1.4 Satellite Coverage Issue

TracVision LF will provide outstanding reception throughout the entire coverage area for your satellite television service of choice. However, signal quality can be degraded as you approach the fringe coverage areas. Refer to your satellite television service manual to check the viable coverage area.

4.1.5 Vehicle Turning During Startup

If the vehicle turns during the 60-second startup and initialization sequence that occurs immediately after turning on the power to the TracVision LF unit, the antenna gyro will record that variable motion as “standing still.” This may cause the antenna to track improperly. To solve this problem, turn the TracVision LF off for at least 10 seconds. Turn the system back on, making certain that the vehicle is either motionless or travelling in a straight line for the 60 seconds immediately following power-up.

4.1.6 Incorrect or Loose RF Connectors

As part of preventive maintenance (described in [Section 5, “Maintenance,”](#)) KVH recommends checking the antenna unit cable connections. A loose RF connector can reduce the signal quality. Refer to [Section 2.3.2, “Connecting the Antenna to the IRD”](#) for directions on proper antenna unit to RF cabling.

4.1.7 Type of Multiswitch Used

An active (not passive) multiswitch must always be used to connect the TracVision LF system to multiple IRDs. Refer to [Section 2.3.2, “Connecting the Antenna to the IRD”](#) for directions on proper multiswitch/multiple IRD cabling.



For your convenience, KVH provides links to several web sites that offer satellite coverage information. Simply go to our web site at www.kvh.com/footprint/index.html.



Baseline RF levels are included as part of the startup sequence provided in [Appendix E](#).

4.2 IRD Troubleshooting

The IRD that was provided with your satellite television service may also be the cause of less-than-ideal operation.

4.2.1 IRD Wiring

Refer to [Section 2.3, “Connecting System Components”](#) and your IRD user manual to confirm that the IRD is properly connected to the antenna unit and the television.



The long-term fix, typically done at original system installation, is to install an Uninterruptible Power Supply (like those available for use with computer systems) on the IRD. Be sure to specify a UPS with adequate available current for all devices attached to it. (An IRD draws approximately 200 watts.)

4.2.2 AC Power Fluctuating

If the system periodically displays a picture for less than one minute, then enters Search Mode 1, the IRD low-speed data port may be locked up as the result of power fluctuations and will require a reset. This can be verified by hooking up a PC to the maintenance port and checking for error messages. Reset must be done by:

1. Completely shutting down DC power to the antenna.
2. Remove the AC source, either at the breaker or by unplugging the IRD.
3. Wait at least 10 seconds before restoring power, first to the IRD and then to the antenna.

4.2.3 No IRD Data Connection

To view status messages, your TracVision antenna must be connected to the IRD’s low-speed data port. Refer to [Section 2.3.4, “Connecting the Switchplate to the IRD”](#) for details.

4.2.4 EchoStar IRD Activation Check

If you have purchased a DISH Network system, there is a chance that your EchoStar IRD will fail to acquire the satellite when you first activate it. This has been known to happen in IRDs that have not been activated within several months of their manufacture. [Appendix D](#) provides the manual satellite acquisition and activation procedure.

4.2.5 Failed IRD Status Check

As detailed in [Appendix E](#), TracVision LF completes a detailed startup routine whenever it is turned on. One of the first checks is the IRD status test. As noted in the typical startup cycles, the expectation is that the IRD and its communications link to TracVision LF will pass this test. There are, however, two alternate results, each indicating a slightly different problem.

Test Result: NONE

If the system tests achieves a result of **NONE**, there is no communication at all between the antenna unit and the IRD.

Solution

Check to be certain that the IRD and TracVision LF are connected properly at the low-speed data port and that both are powered on. Refer to [Section 2.3, “Connecting System Components”](#) for correct antenna unit to IRD wiring procedures and diagrams. After verifying the connection, cycle the power off and on and review the startup test results.

Test Result: UNKNOWN

In the instance of a result of **UNKNOWN**, a communications link exists, but the data received by the antenna unit is garbled and unrecognizable.

Solution

As with a result of **NONE**, first check to be certain the IRD and TracVision LF are connected properly at the low-speed data port. Refer to [Section 2.3, “Connecting System Components”](#) for correct antenna unit to IRD wiring procedures and diagrams. After verifying the connection, cycle the power off and on and review the startup test results. If this does not initially succeed, refer to [Section 4.2.2, “AC Power Fluctuating,”](#) and follow the IRD reset procedure.

4.2.6 IRD Faulty

In the case of a faulty IRD, refer to your IRD user manual for service, replacement, and warranty information.

4.3 Antenna Gyro and LNB Faults

Section 5, "Maintenance," provides detailed instructions for authorized service personnel who may be required to replace the TracVision LF antenna gyro or the LNB.



Most terminal emulation programs have a parameter for local character echo. Select this parameter to see what is being typed without any system delay.

4.4 Computer Diagnostics

TracVision LF has been designed to provide diagnostic readouts viewed on the TV screen (DIRECTV only) or on a personal computer having an RS-232 serial communication port. If you are unable to isolate a system problem with the foregoing troubleshooting tools, set up for computer diagnostics as described below. System problems will most likely be found somewhere through the diagnostic readouts.

The diagnostics procedure requires terminal emulation software such as PROCOMM or Windows Terminal or Hyperterminal. Use the settings appropriate to your application.

1. Connect one end of a PC data cable to the maintenance connector on the antenna baseplate (see Figure 4-1). Connect the other end to the serial port on the PC (a 9-pin/25-pin connector adapter may be needed for some PCs).

Figure 4-1
Maintenance Connector

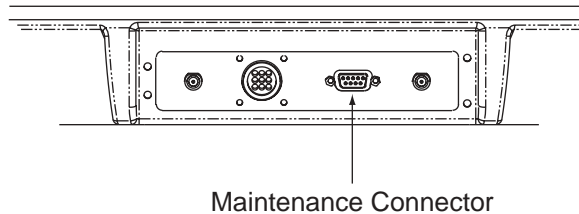
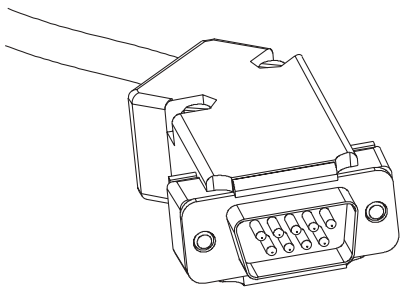

Figure 4-2
PC Data Cable DB9 Connector



2. Open the terminal emulation software and establish the following settings:
 - 9600 baud
 - no parity
 - 8 data bits
 - 1 start bit
 - 1 stop bit
 - no flow control

3. Apply power to the TracVision LF system and allow the system to complete full initialization. Data should be scrolling on the PC display to identify any system problems detected. If no data is seen, recheck your connections and the terminal software setup.

4.5 Maintenance Port Parser Commands

TracVision LF system parser commands are detailed in [Appendix F](#).

5 Maintenance

The following sections provide details on preventive maintenance and field replaceable units and parts for the TracVision LF antenna unit.

5.1 Warranty/Service Information

For information on KVH warranty, repair, and liability policies, please refer to the [complete warranty statement](#) provided at the conclusion of this manual. If you have any questions, please call your local authorized dealer or installer, or contact KVH directly.

5.2 Preventive Maintenance

TracVision LF requires minimal preventive maintenance. The following tasks are sufficient to maintain peak performance.

Monthly

- Wash the exterior of the radome and baseplate assembly with fresh water; a mild detergent may be added to remove grime. Do not spray the radome directly with high-pressure water.
- Do not apply abrasive cleaners or volatile solvents such as acetone to the ABS radome.

Annually

- Remove the radome. Visually inspect the elevation drive shaft to be certain that it moves easily and is clear of grit and debris. Clean and lubricate with silicone or white lithium grease as required.



The serial number of your TracVision LF will be required during any troubleshooting or service calls. You will find the serial number on the *inside front cover* of this manual.

5.3 Replaceable Parts

TracVision LF has been designed with durability and low maintenance in mind. If you experience an operating problem or otherwise require technical assistance, contact your local authorized TracVision LF dealer/installer first. Have the antenna unit serial number ready with a list of the trouble symptoms. If an authorized dealer/installer is not located nearby, contact the factory directly at the telephone, facsimile, or e-mail listings inside the front cover.

Replacement part numbers for units that can be serviced in the field are listed in Table 5-1. These parts may be obtained from any KVH authorized dealer/installer.

Table 5-1
Field Replaceable Units



Should the fuse ever need to be replaced, TracVision LF uses a 5x20mm, 3.15-amp, 250-volt fast-blow fuse.

Part Name	Part Number
Radome Assembly	02-0953-08
Baseplate Assembly	02-1198-01
Data/Power Cable	32-0731-28
RF Cable	32-0417-28
CPU PCB	02-1144-01
Antenna Gyro	02-1035
Antenna Gyro Gasket	24-0139
System Fuse	16-0017-3150
LNB	19-0056

It is recommended that all other technical difficulties be resolved by returning the TracVision LF unit to an authorized service provider.

5.4 Field Replaceable Unit Procedures

The following subsections provide detailed procedures for repairing or swapping out field replaceable units. The procedures refer to labeled items presented on the following diagrams.



Always lift the antenna unit by the gray baseplate, never by the radome or any portion of the antenna assembly!

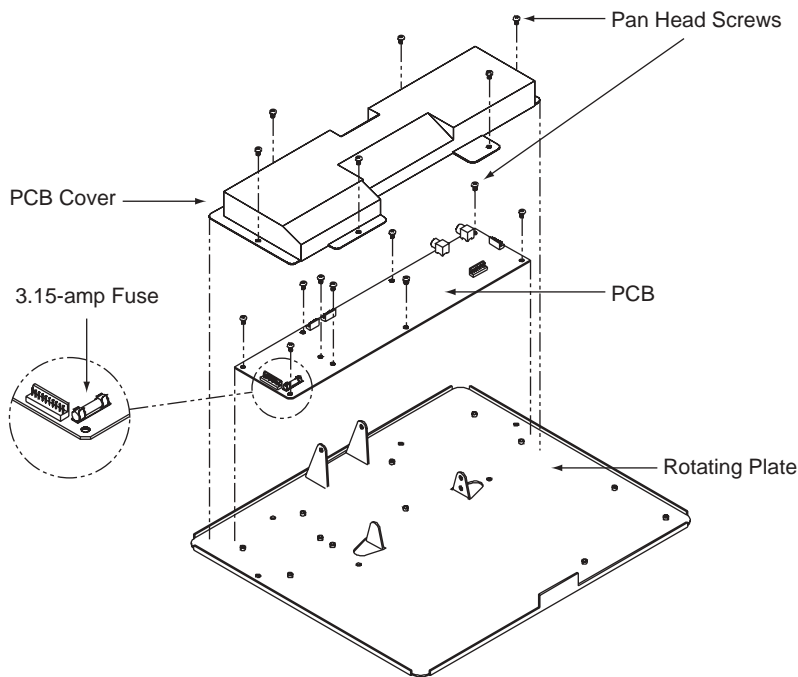

Figure 5-1
Antenna, PCB, and Rotating Plate



Before servicing the antenna unit, be sure to remove the appropriate vehicle fuse to disconnect power. Replace the fuse after completing the service.

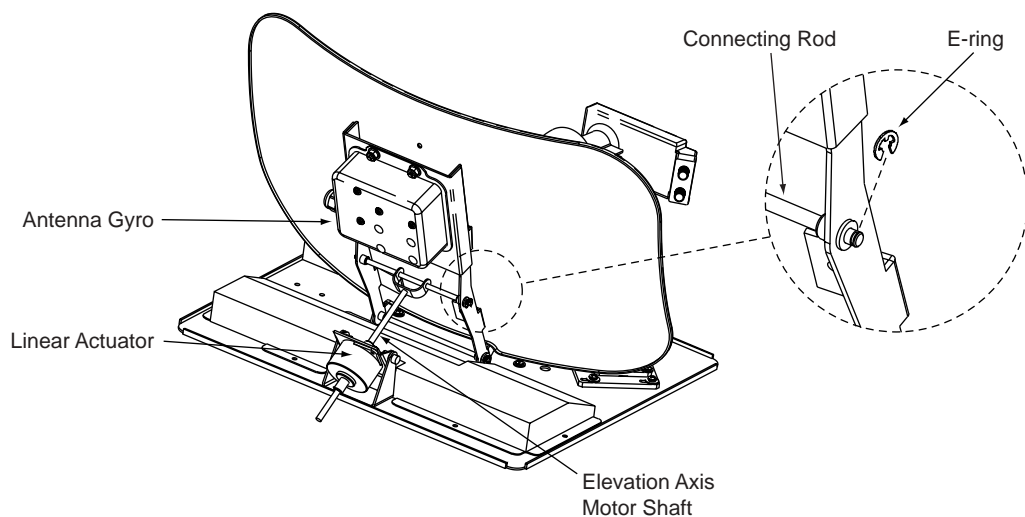

Figure 5-2
Close-up of Connecting Rod and E-ring

Figure 5-3
Antenna Assembly

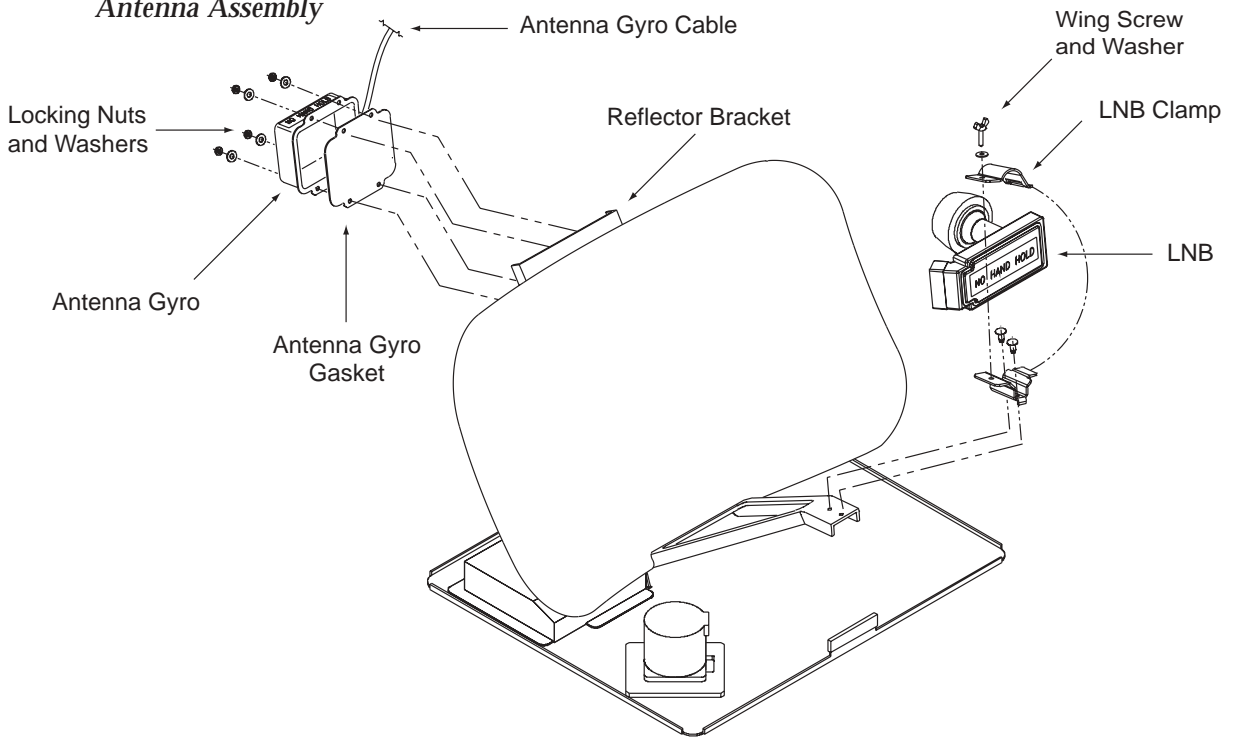
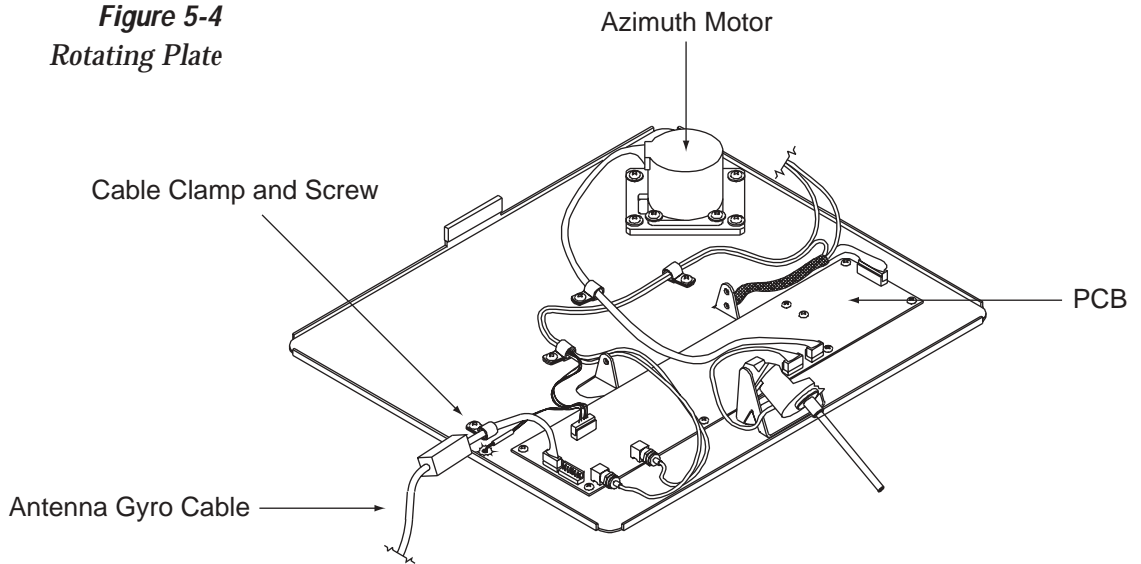

Figure 5-4
Rotating Plate



5.4.1 PCB Removal and Replacement

Estimated Time to Repair: ½ hour

The microprocessor PCB assembly is protected by a cover fastened to the rotating plate – *Fig. 5-1*. The cover must be removed to gain access to the main power fuse and the PCB assembly.

1. Using needle-nose pliers, remove the E-ring from one end of the connecting rod – *Fig. 5-2*.
2. Remove the connecting rod by sliding it off the bracket.
3. Fully retract the elevation axis motor shaft – *Fig. 5-5*.

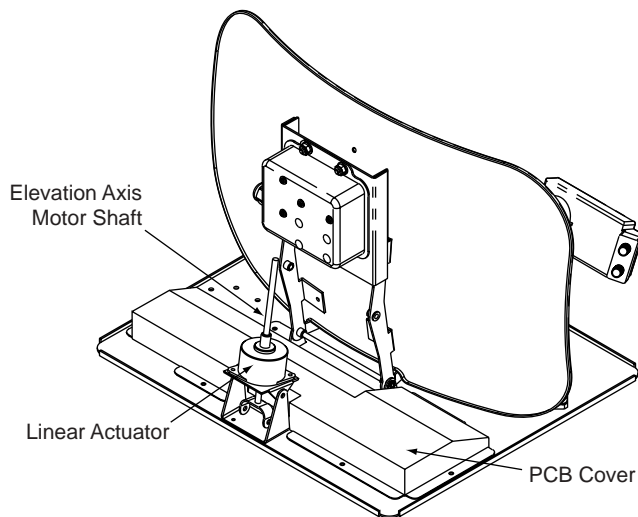

4. Remove 6 pan head screws from the PCB cover flanges.
5. Remove the PCB cover. To get the necessary clearance, rotate the linear actuator up 90° while lifting the PCB cover – *Fig. 5-5*.
6. Remove all cable connectors from the PCB. *Figure 5-6* on the following page illustrates the PCB arrangement and connector locations.



*When carrying out maintenance on the PCB, be sure to not drop any of the small screws inside the mechanism. If a screw is lost within the baseplate, it **must** be retrieved to avoid causing any damage when the unit rotates.*

Figure 5-5
Removing the PCB Cover



TracVision LF is equipped with a 5x20 mm, 3.15-amp, 250 volt fast-blow fuse, which is mounted on the PCB. To access and replace the fuse, remove the PCB cover.

Figure 5-6
PCB Connector Locations –
Rear View

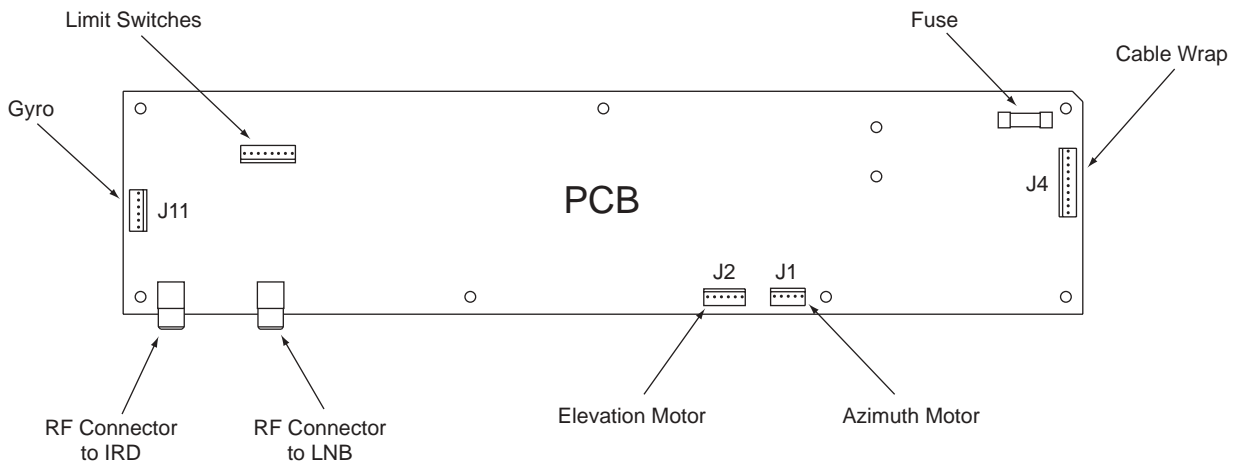

When replacing the PCB cover, be careful not to pinch any cables.

7. Remove the 9 pan head screws securing the PCB to the rotating plate.
8. Reverse this process to install the replacement PCB. Reinstall all cable connectors removed in Step 6.
9. Carry out the LNB calibration procedure ([Section 5.4.3](#)).

5.4.2 Antenna Gyro Assembly

Estimated Time to Repair: 1 hour

The antenna gyro assembly is mounted on the rear of the antenna reflector bracket with four locking nuts and washers – [Fig. 5-3](#). Following the removal and replacement of the antenna gyro assembly, it will be necessary to calibrate the gyro and restart the system. Directions for removal, replacement, and calibration follow:

1. Using needle-nose pliers, remove the E-ring from one end of the connecting rod – [Fig. 5-2](#).
2. Remove the connecting rod by sliding it off the bracket.
3. Fully retract the elevation axis motor shaft – [Fig. 5-5](#).
4. Remove 6 pan head screws from the PCB cover flanges.

5. Remove the PCB cover. To get the necessary clearance, rotate the linear actuator up 90° while lifting the PCB cover – *Fig. 5-5*.
6. Remove the screw and clamp holding the cable to the rotating plate; save the cable clamp for reuse – *Fig. 5-4*.
7. Remove the Molex connector from J11 on the CPU board – *Fig. 5-6*.
8. Remove the 4 locking nuts and flat washers and take the antenna gyro off the bracket.
9. Remove the antenna gyro gasket.
10. Replacement is the reverse of this procedure.

Antenna Gyro Calibration

1. Connect a PC to the communications port as described in *Section 4.4, “Computer Diagnostics.”*
2. Type **HALT<cr>** (*<cr> indicates a carriage return/ENTER key*) while the system is performing the limit switch initialization routine. The system will complete the initialization function by finding the azimuth and elevation switch limits and then go to the home position.
3. Type **DEBUGON<cr>** to enter Debug Mode.
4. Type **EL,300<cr>**.
5. Type **=CALAZ<cr>**. Verify that the Antenna Gyro Azimuth scale factor is between -0.00090 and -0.00110.
6. Type **=CALEL<cr>**. Verify that the Antenna Gyro Elevation scale factor is between 0.00090 and 0.00110.
7. Type **ZAP** to restart/reinitialize the system.

5.4.3 Antenna LNB Replacement

Estimated Time to Repair: ½ hour

The LNB receives preamplifier operating power from the IRD via the PCB – *Fig. 5-3 and 5-4*. Be certain that the IRD is disconnected from its power source before removing or reconnecting the LNB.



When replacing the LNB, make certain to restore it to its original orientation, as shown in *Figure 5-3*.

1. Disconnect both RF coaxial connectors at the LNB.
2. Remove the wing screw and washer from the LNB clamp – *Fig. 5-3*.
3. Remove the top of the LNB clamp – *Fig. 5-3*.
4. Remove the LNB.
5. Replacement is the reverse of this procedure. Check the rotation to ensure that the LNB is not striking any wires or the baseplate.

Antenna LNB Normalization and Stability Test

1. Connect a PC to the maintenance port as described in *Section 4.4, “Computer Diagnostics.”*
2. Ensure that the antenna is tracking the satellite.
3. Type **HALT<cr>** (<cr> indicates a carriage return/ENTER key) to put the system into Idle Mode.
4. Type **DEBUGON<cr>** to put the system into Debug Mode.
5. Type **FINDSAT<cr>** to begin the automatic signal peaking process. Wait until the antenna peaks the satellite signal and is motionless. The screen will display **FINDSAT: PASS**.
6. Type **=CALLNB<cr>** to start the LNB Normalization Function.

Note: The CALLNB Function requires the antenna to be pointed directly at the satellite peak before performing this routine.



The CALLNB Function requires the antenna to be pointed directly at the satellite peak before performing this routine. Using the FINDSAT command will ensure that the antenna is receiving the strongest possible signal.

7. The system must respond with the following message: **CALLNB: PASS**. If the system displays **CALLNB: FAIL**, return to Step 3 and retry the procedure, making sure to achieve the highest possible RF signal peak.

8. Record the Cold Sky Average and the RFGAIN value reported in Step 7.
9. Type **ZAP<cr>**. The system will re-initialize using the new RFGAIN and RFOFFSET scale factors displayed following Step 7.
10. Wait for the system to perform the background noise calculation. Read the Average Noise Level value from the messages transmitted out the maintenance port. This value must be greater than 300 and less than 1300. An example of the message sequence and format is as follows:

*** Averaging Background Noise ***

Average Noise Level = 750

Noise Threshold = 1450

11. Wait for the system to search for, find the satellite, enter Tracking Mode and track the satellite for a minimum of 30 seconds. Record the average RF signal value reported from the +POS: AZ, EL, RF messages. An example of the message sequence and format is as follows:

+POS: 154.5 33.2 2521

12. The RF signal values while tracking shall be greater than 2000 and less than 3000.

5.5 Preparation for Shipment



When rotating the azimuth mechanism by hand, go slowly! Hitting the mechanical stops with excessive force will damage the azimuth limit switch.

Figure 5-7
Baseplate Shipping Restraint Holes

If you need to repack the antenna unit for shipment, you must first secure the LNB. Follow the steps below to repack the antenna unit.

1. Remove the radome.
2. Rotate the antenna unit so that the LNB is facing forward (away from the connector plate) (see Figure 5-7).

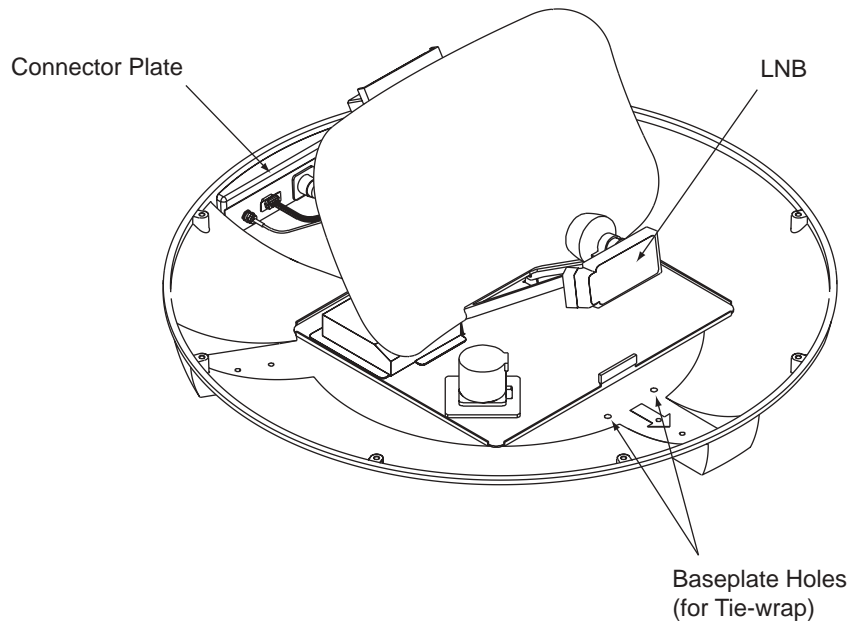

Do **NOT** overtighten the tie-wrap. Securing the tie-wrap too tightly may bend the LNB bracket and damage the unit.

Figure 5-8
Attaching the Shipping Restraint

3. Using a tie-wrap, secure the LNB bracket to the baseplate, as shown in Figures 5-7 and 5-8.

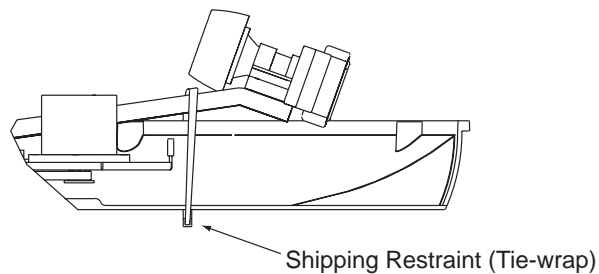

KVH is not liable for damage caused by improper shipping.

4. Replace the radome.
5. Place the entire antenna unit into its shipping box using the original packing material.
6. Secure the box to a pallet to ensure upright transport to KVH.

Appendix A

System Specifications

Physical Characteristics

Power	11-16 volts DC @ 2.5 amps nominal, 3.5 amps peak
Dimensions/Weight	32" wide x 14.8" high, 33 lbs
LNB	Dual Output
Tracking	Better than 30°/sec
Maintenance Port	9600 bps, 8,N,1,EIA, RS232

Table A-1

TracVision LF System Specifications

Pointing System

Elevation Range	15° to 75°
Azimuth Range	720°
Position Repeatability	0.1°

Environmental

Operating Temperature	-13°F to +131°F
Storage Temperature	-40°F to +185°F
Humidity	to 100 percent

Appendix B

Comprehensive TracVision LF System Wiring Diagram

The wiring diagram is presented on the following page.

Appendix C

Switchplate Template

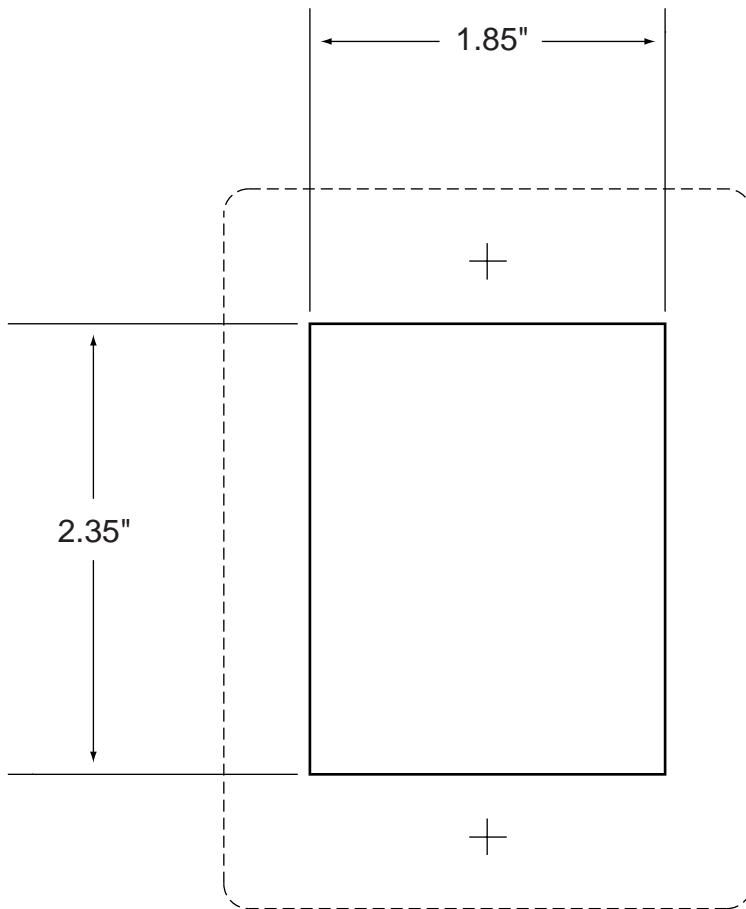

Appendix D

EchoStar IRD Activation Procedure

If you have purchased a DISH Network system, there is a chance that your EchoStar IRD will fail to acquire the satellite when you first activate it. This has been known to happen in IRDs that have not been activated within several months of their manufacture. The following process is a manual method of acquiring the satellite for the first time so that the IRD can download the most up-to-date satellite and programming data, allowing it to automatically acquire the satellite from then on.

Please refer to your EchoStar IRD user manual for complete instructions on the IRD, the remote control, and the command screens.

Manual Satellite Acquisition and IRD Activation

1. Turn on the TV and EchoStar IRD.
2. Using the EchoStar remote, press MENU.
 - The Main Menu will come up on the screen.
3. Select #6, System Setup.
4. Select #1, Installation.
5. Select #1, Point Dish/Signal.
 - The Signal Strength Screen will appear.
6. Using the remote, select the zip code box on the screen, and input the local zip code.
 - The screen will show you the Azimuth and Elevation to the satellite. Write this down.
7. Connect a PC to the antenna's maintenance port.
8. Turn on the TracVision LF.
9. Type **HALT<CR>** after receiving the message ***** Entering Search Mode 1 *****.
10. Type in the elevation that you obtained in Step 6.
 - Type **EL,xxx<CR>**
(e.g., Elevation of 30.2° = **EL,302<CR>**)



It will be necessary to have a PC available to complete the manual acquisition and activation procedure.



The Signal Strength Meter is located on the bottom of the "Point Dish and Signal Strength" Screen. This Signal Strength Meter is Red in color, and turns Green when the proper satellite is located.



Turning the IRD off with the remote puts the IRD in standby mode. Turning the IRD off from the front panel shuts the IRD off.

11. Using a compass, take a bearing on an object that is approximately on the azimuth obtained in Step 6.
12. Type in an azimuth that points the antenna in the direction of the object selected in Step 11.
 - Type **AZ,xxxx<CR>**
(e.g., azimuth of 233° = **AZ,2330<CR>**)
 - Valid azimuth range is 0-360° (0000-3600)
13. Check to see if there is signal strength on the Signal Meter Screen.
14. Move antenna counter-clockwise in 5° increments until signal strength is acquired. If you do not find the satellite, point the antenna at the object selected in Step 11 and move the antenna clockwise in 5° increments until signal strength is acquired.
15. Once the satellite is found, fine tune azimuth in 1° increments for maximum signal strength.
16. Fine tune elevation in 1° increments for maximum signal strength.
17. Once the satellite is found, turn the EchoStar IRD off, using the power button on the infrared remote. *Do not turn off the IRD using the front panel.* Leave IRD in standby mode for approximately 5 minutes. The IRD will now download new software from the satellite.
 - To verify that the IRD has been updated, put the IRD into the Signal Strength Screen mode, and three satellite options will appear on the left side of the screen: 61.5° West, 119° West, 148° West. Your EchoStar IRD is now updated.

Appendix E

Startup Data Sequences

The data on the following pages presents the startup data sequences registered by the TracVision LF. The first section shows the sequences registered by a system that is connected to an IRD low-speed data port. The second section shows the sequences registered by a system that is **NOT** connected to an IRD low-speed data port. Both sections show two routines. One is the standard, full initialization routine; the second is that registered by TracVision LF if it is turned on and acquires the satellite via the “Instant On” operation (described in [Section 3, “Using Your TracVision LF”](#)). These sequences can be recorded using the data port and a PC.

E.1 System Connected to IRD Data

Standard Startup Sequence

```
?PGM
```

```
KVH TracVision LF Rev X - Version X.XX - Serial number XXXXXXXX
```

```
Limit Switch Test
```

```
Limit Switch Status:PASS-----Pass is expected
```

```
*** Initializing IRD ***
```

```
IRD STATUS: PASS DSS -----PASS is expected with successful IRD identification
```

```
Saved Sat Pos: EL = 36.5
```

```
*** Initializing Rate Bias ***
```

```
+POS: 45.0 45.9 548
```

```
VEL_INDEX: Az = 1996, El = 2182 -----Expected range is 1700-2300
```

```
RATE BIAS: PASS-----Az & El values above are within valid ranges
```

```
*** Averaging Background Noise ***
```

```
+POS: 45.0 22.5 356
```

```
+POS: 135.0 20.0 362
```

```
+POS: 311.8 20.0 355
```

```
Average Noise Level = 381
```

```
Noise Threshold = 859
```

```
Saved Sat Pos: EL = 36.5
```

```
*** Entering Search Mode 1 ***
```

```
+POS: 27.0 20.1 354
```

```
+POS: 79.9 36.4 341
```

```
Satellite Found: AZ = 62.26, EL = 36.50, RF = 1300
```

```
+POS: 53.6 36.5 449
```

```
*** Entering Tracking ***
+POS:  61.8  36.5 1260
+POS:  62.2  36.3 1346
+POS:  64.0  36.5 1716
*** Entering Satellite Check *** -----Confirming proper satellite lock
+POS:  64.3  36.1 1747
Satellite Located
IRD Signal Quality = 54
+POS:  66.1  35.6 1522
+POS:  64.6  35.5 1749
IRD Signal Quality = 58
+POS:  66.2  36.1 1467
+POS:  64.5  35.8 1757
```

"Instant On" Startup Sequence

?PGM

KVH TracVision LF Rev X - Version X.XX - Serial Number XXXXXXXX

Instant On-----System skips limit switch test

Limit Switch Status: PASS-----PASS is expected

*** Initializing IRD ***

...

IRD STATUS: PASS DSS -----PASS is expected with successful IRD
identification

Saved Sat Pos: EL = 33.3

*** Initializing Rate Bias ***

+POS: 360.0 33.9 2625

VEL_INDEX: Az = 1996, El = 2182 -----Expected range is 1700-2300

RATE BIAS: PASS -----Az & El values above are within valid ranges

*** Initializing Finetune ***-----Peaking the satellite signal

+POS: 360.0 33.9 2622

Signal Peaked: AZ = 0.00, EL = 33.30, RF = 2674

+POS: 0.0 33.3 2646

+POS: 0.0 33.3 2638

IRD Signal Quality = 79

+POS: 0.0 33.3 2640

+POS: 0.0 33.3 2614

IRD Signal Quality = 77

CH = 200 XP = 7 HI = 0 LO = 10

+POS: 0.0 33.3 2652

Saved Sat Pos: AZ = 0.00, EL = 33.30

+POS: 0.0 33.3 2617

+POS: 0.0 33.3 2616

IRD Signal Quality = 78

+POS: 0.0 33.3 2610

E.2 System Not Connected to IRD Data

Standard Startup Sequence

```
?PGM

KVH TracVision LF Rev X - Version X.XX - Serial Number XXXXXXXXX

Limit Switch Test
Limit Switch Status: PASS-----PASS is expected
*** Initializing IRD ***
Send APG OSD On
Try MPG IRD Type
Send MPG OSD On
Switch Back to Echostar IRD Type
Send APG OSD On
Try MPG IRD Type
Send MPG OSD On
Switch Back to Echostar IRD Type
IRD STATUS: FAIL None -----FAIL is expected with no IRD data connection
Saved Sat Pos: EL = 33.5
*** Initializing Rate Bias ***
+POS: 360.0 33.9 2625
VEL_INDEX: Az = 1996, El = 2182 -----Expected range is 1700-2300
RATE BIAS: PASS -----Az & El values above are within valid ranges
*** Averaging Background Noise ***
+POS: 45.0 26.3 762
+POS: 62.1 20.0 1111
+POS: 223.5 20.0 1082
Average Noise Level = 985
Nor = 1826
Saved Sat Pos: EL = 33.5
*** Entering Search Mode 1 ***
+POS: 193.4 30.1 1098
+POS: 205.8 33.5 878
Satellite Found: AZ = 330.0, EL = 33.5, RF = 2150
+POS: 0.9 33.5 586
+POS: 331.2 33.5 2173
*** Initializing Finetune ***-----Peaking the satellite signal
+POS: 331.2 33.5 2197
+POS: 331.8 34.1 2177
Signal Peaked: AZ = 331.79, EL = 33.50, RF = 2226
*** Tracking Satellite ***
+POS: 331.7 33.4 2154
+POS: 331.7 33.4 2167
Saved Sat Pos: AZ = 331.75, EL = 33.43
+POS: 331.7 33.4 2155
+POS: 331.7 33.4 2132
```

```
+POS: 331.7 33.4 2153
Switch held: wrong satellite-----SAT SELECT switch pressed
Exclude: No longer search AZ = 331.7, EL = 33.4
*** Entering Search Mode 1 *** -----Searching for a different satellite
Search1 decided to go to: AZ = 335.9, EL = 33.5
+POS: 23.5 33.5 518
+POS: 162.5 33.5 1105
*** Entering Search Mode 2 ***
+POS: 150.5 33.4 1108
+POS: 80.1 33.4 889
+POS: 180.0 34.0 1092
*** Entering Search Mode 3 ***
+POS: 180.0 34.3 873
+POS: 66.6 22.0 885
Satellite Found: AZ = 348.8, EL = 22.0, RF = 2149
+POS: 327.4 22.0 567
*** Initializing Finetune ***
+POS: 348.8 22.0 1987
+POS: 348.8 23.8 1965
Signal Peaked: AZ = 348.77, EL = 23.23, RF = 2004
*** Tracking Satellite ***
+POS: 348.8 23.3 2100
+POS: 348.8 23.3 1840
Saved Sat Pos: AZ = 348.76, EL = 23.29
+POS: 348.8 23.3 2190
+POS: 348.8 23.3 2010
```

“Instant On” Startup Sequence

?PGM

KVH TracVision LF Rev X - Version X.XX - Serial Number XXXXXXXXX

```
Instant On-----System skips limit switch test
Limit Switch Status: PASS-----PASS is expected
*** Initializing IRD ***
Send APG OSD On
Try MPG IRD Type
Send MPG OSD On
Switch Back to Echostar IRD Type
Send APG OSD On
Try MPG IRD Type
Send MPG OSD On
Switch Back to Echostar IRD Type
IRD STATUS: FAIL None -----FAIL is expected with no IRD data connection
Saved Sat Pos: EL = 22.5
*** Initializing Rate Bias ***
+POS: 360.0 33.9 2625
```

```
VEL_INDEX: Az = 1996, El = 2182 -----Expected range is 1700-2300
RATE BIAS: PASS -----Az & El values above are within valid ranges
*** Initializing Finetune ***
+POS: 360.0 23.1 1575
Signal Peaked: AZ = 0.00, EL = 22.50, RF = 1919
*** Tracking Satellite ***
+POS: 360.0 22.5 1917
+POS: 360.0 22.5 1976
Switch held: wrong satellite-----SAT SELECT switch pressed
Exclude: No longer search AZ = 0.0, EL = 22.5
```

KVH TracVision LF Rev X - Version X.XX - Serial Number XXXXXXXX

```
Limit Switch Test
Limit Switch Status: PASS
*** Initializing IRD ***
Send APG OSD On
Try MPG IRD Type
Send MPG OSD On
Switch Back to Echostar IRD Type
Send APG OSD On
Try MPG IRD Type
Send MPG OSD On
Switch Back to Echostar IRD Type
IRD STATUS: FAIL None
Saved Sat Pos: EL = 22.5
*** Initializing Rate Bias ***
+POS: 360.0 33.9 2625
VEL_INDEX: Az = 1996, El = 2182 -----Expected range is 1700-2300
RATE BIAS: PASS -----Az & El values above are within valid ranges
*** Averaging Background Noise ***
+POS: 45.0 26.3 956
+POS: 62.1 20.0 1094
+POS: 223.5 20.0 850
Average Noise Level = 965
Noise Threshold = 1794
Saved Sat Pos: EL = 22.5
*** Entering Search Mode 1 *** -----Searching for a different satellite
+POS: 193.4 22.5 869
+POS: 205.8 22.5 1083
Satellite Found: AZ = 350.6, EL = 22.5, RF = 2015
+POS: 15.0 22.5 471
+POS: 354.0 22.5 620
*** Initializing Finetune ***
+POS: 350.0 22.5 1773
+POS: 350.5 21.9 1959
Signal Peaked: AZ = 350.55, EL = 22.50, RF = 1978
*** Tracking Satellite ***
+POS: 350.5 22.4 1674
```

Appendix F

Maintenance Port Parser Commands

TracVision LF system parser commands are parsed when the system receives an ASCII carriage return (Hex 0D). An ASCII line feed (Hex 0A) is permitted but is ignored in any transmitted command. All system responses are terminated with an ASCII carriage return followed by a line feed and ending with either an acknowledge character (ASCII > (Hex 3E)) or a not-acknowledge character (ASCII ? (Hex 3F)). The parser commands are shown below in boldface capital letters but they are not case-sensitive. In most cases the command is responded to with an echo; that is, if you type **ZAP**, for example, and press “ENTER,” the response will be the command you have entered (i.e., **ZAP**). For other commands the response is specific for each command, such as **VERSION**, **STATUS**, or **HELP**.

F.1 System Commands

Software Version

Function	reports software version
Command	VERSION
Argument	none
Response	KVH TVLF Version XX.XX

*Table F-1
System Commands*

System Status Report

Function:	reports general system status
Command:	STATUS
Argument:	none
Response:	system status string, (TBD)

Initialize the System

Function:	initializes the system (perform a soft reset)
Command:	ZAP
Argument:	none
Response:	echoes the command, then reinitializes the system

F.2 Manual Positioning Commands

To execute the following commands, first put the antenna unit in idle mode by typing **HALT** and pressing “ENTER.” Positioning commands may be entered after the antenna comes to rest.

Table F-2
Manual Positioning Commands

Help on Parser Commands

Function:	lists parser commands
Command:	HELP
Argument:	none
Response:	print a list of all parser commands

Azimuth Angle

Function:	commands a manual azimuth angle that the mechanism moves to
Command:	AZ,xxxx (range is 0000-3599)
Argument:	desired azimuth angle of the mechanism relative to vehicle reference, or baseplate fwd, 000°-359.9° (vehicle-referenced)
Response:	echoes the command; mechanism moves at a fixed velocity

Elevation Angle

Function:	commands a manual elevation angle that the mechanism moves to
Command:	EL,xxx (range is 100-700)
Argument:	desired elevation angle of the mechanism relative to up, or external sensor attitude reference, 10.0°-70.0°
Response:	echoes the command; mechanism moves at a fixed velocity

Azimuth CW Step

Function:	commands a 0.1 deg CW manual step in azimuth angle
Command:	6
Argument:	none
Response:	echoes the command

Azimuth CCW Step

Function:	commands a 0.1 deg CCW manual step in azimuth angle
Command:	4
Argument:	none
Response:	echoes the command

Elevation UP Step

Function:	commands a 0.1 deg UP manual step in elevation angle
Command:	8
Argument:	none
Response:	echoes the command

Elevation DOWN Step

Function:	commands a 0.1 deg DOWN manual step in elevation angle
Command:	2
Argument:	none
Response:	echoes the command

F.3 Operational Commands

Idle Mode

Function:	halts active tracking and conical scan, then enters idle mode
Command:	HALT
Argument:	none
Response:	echoes the command

*Table F-3
Operational Commands***Current Cable Wrap Angle**

Function:	sets or reports current cable wrap angle, defined as 0° (CCW limit) to 700° (CW limit); the value is expressed as 0000-7000 with an implied decimal
Command:	WRAPANGLE,xxxx
Argument:	the desired cable wrap angle setting
Response:	Wrap Angle = xxxf

F.4 Target and Signal Commands

Table F-4
Target and Signal Commands

Report Target Location

Function:	reports the target (satellite) location in the baseplate frame and uses the saved satellite position
Command:	TGTLOCATION
Argument:	none
Response:	Target Location = E XXX, A XXXX

Report RF Signal Strength

Function:	reports the modified signal strength from the RF power detector circuit, and applies the RF gain and offset computed during LNB calibration
Command:	SIGLEVEL
Argument:	none
Response:	Signal Strength = XXXX

Report IRD Signal Quality

Function:	reports the signal strength from the IRD; it uses the last received signal quality and initiates a new signal quality request command from the IRD
Command:	SIGQUALITY
Argument:	none
Response:	Stale Signal Quality = XX

Report IRD Type

Function:	reports the IRD connection type as DSS (DIRECTV), EchoStar, untested, or none
Command:	IRDTYPE
Argument:	none
Responses:	IRD type has not been tested yet. IRD type is Echostar. IRD type is DSS. IRD type cannot be determined.

KVH Industries Limited Warranty

TracVision LF

Limited Warranty on Hardware

KVH Industries, Inc. warrants the KVH product purchased against defects in materials for a period of TWO (2) years and against factory labor costs for a period of ONE (1) year from the date of original retail purchase by the original purchaser. It is the customer's responsibility to verify the date of purchase by returning the warranty card included with the product to KVH within 30 days of purchase, or by providing a copy of a dated sales receipt for the KVH product under warranty with the warranty claim. If this date cannot be verified, the warranty period will begin 30 days after the date of manufacture of the original product purchased.

If you discover a defect, KVH will, at its option, repair, replace or refund the purchase price of the product at no charge to you, provided you return it during the warranty period, transportation charges prepaid, to the factory direct. Please attach your name, address, telephone number, a description of the problem and a copy of the bill of sale or sales receipt as proof of date of original retail purchase, to each product returned to warranty service. Alternatively, you may bring the product to an Authorized KVH TracVision Dealer for repair. During the first year, and if the product was installed by an Authorized KVH TracVision Dealer (identified with the KVH Authorized TracVision dealer list), KVH will cover the dealers' labor charges for warranty repairs, provided the dealer contacts KVH for pre-approval of the charges. Approval of charges is at KVH's sole discretion.

This Limited Warranty does not apply if the product has been damaged by accident, abuse, misuse or misapplication or has been modified without the written permission of KVH; if any KVH serial number has been removed or defaced; or if any factory-sealed part of the system has been opened without authorization.

Return Authorization

A Return Material Authorization is required prior to returning the product to KVH Industries. Please call our Technical Support Department at (401) 847-3327 or send an e-mail to techs@kvh.com to obtain the RMA number. Write the number in large, clear characters on the outside of the box. To avoid confusion and misunderstandings, shipments without an RMA number clearly visible on the outside box will be refused and returned to you at your expense. If possible, use the original box and packing material to protect the equipment from damage in shipment. KVH assumes no responsibility for warranty shipments from the customer to the factory if not shipped in the manner prescribed above.

THE EXPRESS WARRANTIES SET FORTH ABOVE ARE THE ONLY WARRANTIES GIVEN BY KVH WITH RESPECT TO ANY PRODUCT FURNISHED HEREUNDER; KVH MAKES NO OTHER WARRANTIES, EXPRESS, IMPLIED OR ARISING BY CUSTOM OR TRADE USAGE, AND SPECIFICALLY DISCLAIMS ANY WARRANTY OF MERCHANTABILITY OR OF FITNESS FOR A PARTICULAR PURPOSE. SAID EXPRESS WARRANTIES SHALL NOT BE ENLARGED OR OTHERWISE AFFECTED BY TECHNICAL OR OTHER ADVICE OR SERVICE PROVIDED BY KVH IN CONNECTION WITH ANY PRODUCT.

KVH's liability in contract, tort or otherwise arising out of or in connection with any product shall not exceed the price paid for the product. IN NO EVENT SHALL KVH BE LIABLE FOR SPECIAL, PUNITIVE, INCIDENTAL, TORT OR CONSEQUENTIAL DAMAGES OR LOST PROFITS OR GOODWILL (INCLUDING ANY DAMAGES RESULTING FROM LOSS OF USE, DELAY IN DELIVERY OR OTHERWISE) ARISING OUT OF OR IN CONNECTION WITH THE PERFORMANCE OR USE OR POSSESSION OF ANY PRODUCT, OR ANY OTHER OBLIGATIONS RELATING TO THE PRODUCT, EVEN IF KVH HAS BEEN ADVISED OF THE POSSIBILITY OF SUCH DAMAGES.

If any implied warranty, including implied warranties of merchantability and fitness for a particular purpose, cannot be excluded under applicable law, then such implied warranty shall be limited in duration to ONE (1) YEAR from the date of the original retail purchase of this product by the original purchaser.

Some states do not allow the exclusion or limitation of implied warranties or liability for incidental or consequential damages, so the above limitations may not apply to you. This warranty gives you specific legal rights, and you may also have other rights which vary from state to state.



KVH Industries, Inc.

50 Enterprise Center • Middletown, RI 02842 • U.S.A.

Phone: +1 401 847-3327 • Fax: +1 401 849-0045 • E-mail: info@kvh.com • Internet: www.kvh.com

KVH® and TracVision® are registered trademarks of KVH Industries, Inc.