

A Guide to TracVision S3 owner's manual

- Installation Instructions
- User's Guide
- Technical Manual



KVH TracVision® S3

Satellite Television

TracVision S3 Owner's Manual Addendum



(ECO #6138)

The following information applies to Revision C of the TracVision S3 Owner's Manual (KVH Part Number 54-0182).

Table 5-1 has been updated to show the new part number for the RF PCB.

5.3 Replaceable Parts

| Part Name | Part Number |
|---------------------------------|-----------------------------|
| Baseplate Assembly | 02-1245-02* 02-1245-04** |
| Radome Assembly | 02-0953-05† |
| Data/Power Cable | 32-0730-28 |
| RF Cable | 32-0417-28 |
| PC Cable | 32-0628-06 |
| CPU PCB | 02-1043-02 |
| RF PCB | 02-1237 |
| System Fuses | 16-0017-3150 |
| LNB (European System) | 19-0196 |
| LNB (N. American System) | 19-0056 |
| Switchplate | 02-1023-01 |
| TV/SAT Switch <i>(optional)</i> | 01-0245 |

Table 5-1
Field Replaceable Units

* Baseplate assembly with single-output LNB

** Baseplate assembly with dual-output LNB

† Specify color when ordering

TracVision S3 Owner's Manual Addendum

(ECO #6040)

The following information applies to Revision C of the TracVision S3 Owner's Manual (KVH Part Number 54-0182).

2 Installation

Kitpack Contents

Two plugs have been added to the kitpack for sealing the predrilled holes in the antenna baseplate.

| Part | Qty. | KVH Part No. |
|-----------------------------------|----------|-------------------|
| Tie-wraps | 5 | 22-0013 |
| Clamshell ventilator | 1 | 19-0230 |
| #6 x 3/4" thread-forming screws | 3 | 14-0298-12 |
| 1/4"-20 x 5/8" hex screws | 4 | 14-0250-0010 |
| 1/4" flat washers | 4 | 14-0251 |
| Switchplate bulb assembly (spare) | 1 | 19-0193 |
| 3/8" hole plugs | 2 | 19-0282-06 |

Table 2-2
Kitpack Contents

2.2 Mounting the Antenna Unit

A step has been added to the antenna mounting procedure. The hole plugs need to be installed before mounting the antenna unit to the vehicle.

- 6. Set aside the antenna unit and clean the roof's surface to remove any debris.
- 6b. Seal the two baseplate holes shown in Figure 2-4 with the plugs provided in the kitpack.**

Figure 2-4
Antenna Baseplate (Bottom View)

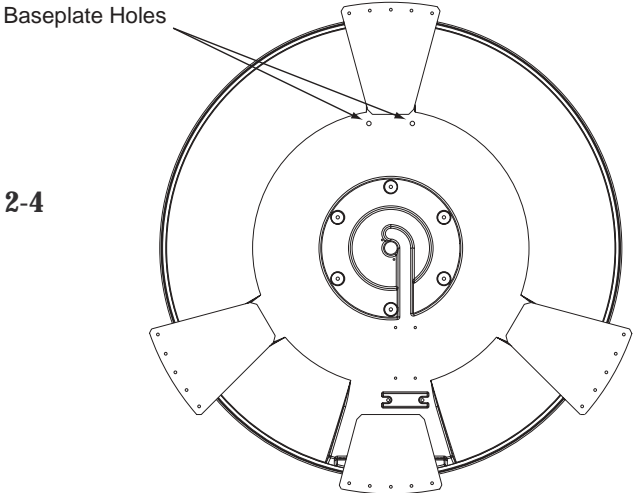

Congratulations!

You have selected one of the most advanced automatic satellite tracking systems available today. KVH® Industries' TracVision® S3 is designed for use with European and North American DVB-compatible satellite services as well as DIRECTV®. This manual provides detailed instructions on the proper installation, use, and maintenance of your TracVision S3 system.

Throughout this manual, important information is marked for your attention by these icons:



A helpful tip that either directs you to a related area within the manual or offers suggestions on getting the highest quality out of your system.



An alert to important information regarding procedures, product specifications, or product use.



Information about installation, maintenance, troubleshooting, or other mechanical issues.



An electrical safety warning to help identify electrical issues that can be a hazard to either this KVH product or a user.



TracVision S3 Serial Number



This serial number will be required for all troubleshooting or service calls made regarding this product.

Direct questions, comments, or suggestions to:

KVH Industries, Inc.
50 Enterprise Center
Middletown, RI 02842 USA
Tel: +1 401 847-3327
Fax: +1 401 849-0045
E-mail: info@kvh.com
Internet: www.kvh.com

KVH Europe A/S
Ved Klaedebo 12
2970 Hoersholm Denmark
Tel: +45 45 16 01 80
Fax: +45 45 86 70 77
E-mail: info@kvh.dk
Internet: www.kvh.com

[Click here to go to our state-of-the-art Customer Support web page...the fastest and easiest way to get all of your questions answered!](#)

If you have any comments regarding this manual, please e-mail them to manuals@kvh.com. Your input is greatly appreciated!



KVH Part # 54-0182 Rev. C
© 2003, KVH Industries, Inc.

KVHI[™]
NASDAQ
LISTED

TracVision[®], KVH[®], and TracNet[™] are official trademarks of KVH Industries, Inc.

DIRECTV[®] is an official trademark of DIRECTV, Inc., a unit of GM Hughes Electronics.

DISH Network[™] is an official trademark of EchoStar Communications Corporation.

ExpressVu is a property of Bell ExpressVu, a wholly owned subsidiary of Bell Satellite Services.

DirecPC[®] is a registered trademark of Hughes Network Systems, a unit of GM Hughes Electronics.

Table of Contents

- 1 Introduction1-1**
- 1.1 Digital Satellite Television1-1**
- 1.2 TracVision S3 System Overview1-2**
 - 1.2.1 TracVision S3 Components1-3
 - 1.2.2 Integrated Receiver Decoder (IRD)1-3
- 1.3 Materials Provided with TracVision S31-4**
 - 1.3.1 Additional Materials Required for TracVision S3 Use1-4

- 2 Installation2-1**
- 2.1 Choosing the Best Location2-3**
- 2.2 Mounting the Antenna Unit2-4**
- 2.3 Connecting System Components2-8**
 - 2.3.1 Connecting the Antenna Data/Power Cable2-9
 - 2.3.2 Connecting to Vehicle Power2-10
 - 2.3.3 Connecting the IRD Ground Wire2-11
 - 2.3.4 Installing the Switchplate2-11
 - 2.3.5 Connecting the Antenna RF Signal Cable to the IRD2-12
 - 2.3.5.1 Installing Two IRDs and TVs (North American Systems Only)2-12
 - 2.3.5.2 Connecting Three or More IRDs and TVs (North American Systems Only)2-13
 - 2.3.6 Sealing the Cable Access Hole2-14
- 2.4 Activating the IRD2-14**
- 2.5 Selecting the Active Satellite2-15**
 - 2.5.1 Installing Your Selected Satellites2-16
 - 2.5.2 Programming User-defined Satellites2-18
- 2.6 Setting the Skew Angle (European Systems Only)2-23**
- 2.7 Checking Out the System2-23**
- 2.8 Configuring TracVision S3 for Remote Satellite Dish Operation2-25**
- 2.9 Changing Geographic Location2-26**

| | | |
|------------|--|------------|
| 3 | Using Your TracVision S3 | 3-1 |
| 3.1 | Turning on the System | 3-1 |
| 3.2 | Changing Channels and Switching Between Satellites | 3-2 |
| | 3.2.1 Using the IRD Remote Control to Switch Between Satellites | 3-2 |
| | 3.2.2 Using the TV/SAT Switch to Switch Between Satellites | 3-3 |
| | 3.2.3 Using a PC to Switch Between Satellites | 3-4 |
| 3.3 | Watching Television | 3-5 |
| 3.4 | Internet Access | 3-5 |
| 4 | Troubleshooting | 4-1 |
| 4.1 | Causes and Remedies for Common Operational Issues | 4-1 |
| | 4.1.1 Blown Fuse or Improper Wiring | 4-2 |
| | 4.1.2 Incorrect Satellite Configuration | 4-2 |
| | 4.1.3 Satellite Signal Blocked | 4-2 |
| | 4.1.4 Dew or Rain Pooling on Dome | 4-3 |
| | 4.1.5 Satellite Coverage Issue | 4-3 |
| | 4.1.6 Incorrect or Loose RF Connectors | 4-3 |
| | 4.1.7 Type of Multiswitch Used (North American Systems Only) | 4-3 |
| | 4.1.8 Stationary Use Only | 4-4 |
| 4.2 | IRD Troubleshooting | 4-4 |
| | 4.2.1 IRD Wiring | 4-4 |
| | 4.2.2 IRD Faulty | 4-4 |
| 4.3 | Antenna LNB Faults | 4-4 |
| 4.4 | Computer Diagnostics | 4-5 |
| 4.5 | Maintenance Port Parser Commands | 4-5 |
| 5 | Maintenance | 5-1 |
| 5.1 | Warranty/Service Information | 5-1 |
| 5.2 | Preventive Maintenance | 5-1 |
| 5.3 | Replaceable Parts | 5-2 |

| | | |
|-------------------|--|------------|
| 5.4 | Field Replaceable Unit Procedures | 5-3 |
| 5.4.1 | PCB Removal and Replacement | 5-5 |
| 5.4.2 | RF Detector/DVB Decoder | 5-6 |
| 5.4.3 | Antenna LNB Replacement | 5-7 |
| 5.5 | Preparation for Shipment | 5-8 |
| Appendix A | System Specifications | |
| Appendix B | Comprehensive TracVision S3 System Wiring Diagram | |
| Appendix C | Switchplate Template | |
| Appendix D | Startup Data Sequence | |
| Appendix E | Maintenance Port Parser Commands | |

1 Introduction

1.1 Digital Satellite Television

Your new TracVision S3 satellite antenna is fully compatible with the Digital Video Broadcasting (DVB) satellites, which use the international standard for digital TV transmission, as well as Digital Satellite Service (DSS) services, such as DIRECTV®. As a result, you will be able to receive and decode signals from your chosen satellite services with the proper programming and hardware (e.g., the IRD [satellite TV receiver]). Your TracVision S3 is also fully compatible with KVH's TracNet™ 2.0 Mobile High-speed Internet System (for more information, please visit our web site at www.kvh.com).

Your TracVision S3 comes with a pre-programmed “satellite library” of European and North American satellite services. When configuring the TracVision S3, you may choose a pair of satellites from the entire library to be active in the system and with your IRD. For the antenna to track and receive signals from two satellites, they must be within 10° longitude of each other in orbit. As a result, certain satellites can be paired only with certain other satellites. Tables 1-1 and 1-2 list the possible satellite pairs that may be selected in Europe and in North America. *If the satellite service you wish to receive is not already in the “satellite library,” you may also add two additional satellites of your choice to the library.*



TracVision S3 is a self-acquiring satellite TV antenna for use when your vehicle is stationary. The system is not designed to track the TV satellite when the vehicle is moving.



TracVision S3's default satellite pairs are:

Europe: Astra 1 & Hotbird

N. America (ExpressVu):
Expressvu & None
or

N. America (US DISH Network):
Echo_119 & None
or

N. America (US DIRECTV):
DSS_101 & DSS_119

Refer to Section 2.5, “Selecting the Active Satellite,” for instructions on selecting different satellites.

Table 1-1
Available European Satellite Pairs
(European LNB Required)

| | Astra 1 | Astra 2N | Astra 2S | Hispasat | Hotbird | Sirius | Thor |
|----------|---------|----------|----------|----------|---------|--------|------|
| Astra 1 | | ✓ | ✓ | | ✓ | ✓ | |
| Astra 2N | ✓ | | | | ✓ | | |
| Astra 2S | ✓ | | | | ✓ | | |
| Hispasat | | | | | | | |
| Hotbird | ✓ | ✓ | ✓ | | | ✓ | |
| Sirius | ✓ | | | | ✓ | | ✓ |
| Thor | | | | | | ✓ | |

Table 1-2
 Available N. American Satellite
 Pairs (U.S.-style LNB required)

| | DSS_101 | DSS_119 | Echo_61 | Echo_110 | Echo_119 | Echo_148 | Expressvu |
|-----------|---------|---------|---------|----------|----------|----------|-----------|
| DSS_101 | | ✓ | | | | | |
| DSS_119 | ✓ | | | | | | |
| Echo_61 | | | | ✓ | ✓ | | ✓ |
| Echo_110 | | | ✓ | | ✓ | ✓ | ✓ |
| Echo_119 | | | ✓ | ✓ | | ✓ | ✓ |
| Echo_148 | | | | ✓ | ✓ | | ✓ |
| Expressvu | | | ✓ | ✓ | ✓ | ✓ | |



If you are a **DISH 500** customer, you can order the optional TV/SAT Switch – **free of charge**. Simply fill out the order form located at the back of this manual and fax it to KVH at +1 401 845-8190.

1.2 TracVision S3 System Overview

A complete satellite TV system includes the TracVision S3 connected to an IRD and a television set. The optional TV/SAT Switch allows you to select a satellite at the press of a button. A desktop or laptop computer is used to configure the system for satellite selection and conduct diagnostics. The complete system is illustrated in Figure 1-1.

System specifications and a wiring diagram are provided in *Appendices A* and *B*, respectively.

Figure 1-1
 TracVision S3 System
 Configuration

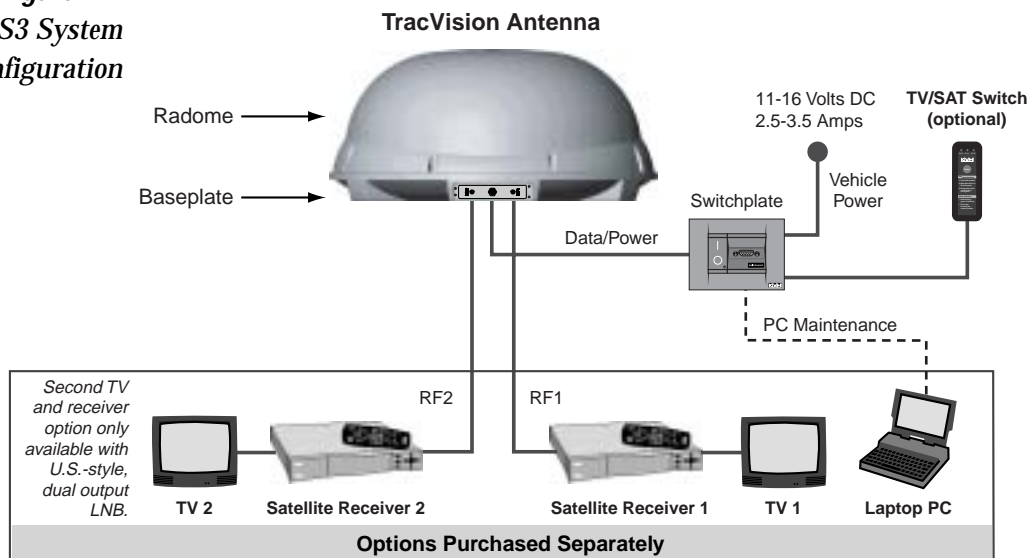

1.2.1 TracVision S3 Components

The antenna unit includes the antenna positioning mechanism, signal front end, power supply, and control elements. The antenna is a parabolic dish mounting a low noise block (LNB) converter with built-in preamplifier. The European configuration includes a single-output LNB while the North American system uses a dual-output LNB. A molded ABS radome encloses the fiberglass baseplate and is secured in place with standard fasteners. Connectors on the back of the baseplate join the power, signal, and control cabling from units inside the vehicle.

1.2.2 Integrated Receiver Decoder (IRD)

The IRD (purchased separately) receives satellite signals from the antenna unit for signal processing and channel selection, and sends the signals to the TV set for viewing. The IRD also provides the interface for the user to activate authorization for reception. Please refer to the User's Manual provided with your selected IRD for complete operating instructions.



The dual-output LNB in the North American systems allows two IRD/TV pairs to be connected directly to the antenna. Three or more pairs can be connected to the system if an active multiswitch is used. [Section 2.3.5, "Connecting the Antenna RF Signal Cable to the IRD,"](#) provides installation directions for each of these options.



Before you can start watching satellite TV using your TracVision antenna, you will need to activate your IRD. Refer to [Section 2.4, "Activating the IRD,"](#) for more details.

1.3 Materials Provided with TracVision S3

Table 1-3 lists the units, cables, and materials packed in the TracVision S3 package by name and KVH part number.

Table 1-3
TracVision S3 Packing List



Cables for the TracVision S3 are stored beneath the antenna unit during shipping.

| Component | KVH Part No. |
|-----------------------------------|--|
| Antenna Unit (comprising): | 01-0225-21 [†] 01-0225-27 ^{††} 01-0225-30 ^{†††} 01-0225-24 ^{††††} |
| Baseplate Assembly | 02-1245-02* 02-1245-04** |
| Radome Assembly | 02-0953-05 |
| RF Cable (28 ft/8.5 m) | 32-0417-28 |
| Data/Power Cable (28 ft/8.5 m) | 32-0730-28 |
| PC Cable (6 ft/1.8 m) | 32-0628-06 |
| Kitpack ^{***} | 72-0101 |
| Owner's Manual | 54-0182 |
| IRD Ground Wire | 32-0583-50 |
| Switchplate | 02-1023-01 |
| TV/SAT Switch (<i>optional</i>) | 01-0245 |

[†] European TracVision S3 system

^{††} North American TracVision S3 system (defaulted to US DISH Network)

^{†††} North American TracVision S3 system (defaulted to ExpressVu)

^{††††} North American TracVision S3 system (defaulted to DIRECTV)

* Baseplate assembly with single-output LNB

** Baseplate assembly with dual-output LNB

*** A complete listing of kitpack contents is provided in [Table 2-2](#).

1.3.1 Additional Materials Required for TracVision S3 Use



In North America, you can purchase and activate an IRD directly from KVH. Call KVH at 1-888-584-4163 for details.

To make full use of your new TracVision S3 and receive satellite TV on the road, you will need to provide/purchase the following:

- Television
- Appropriate IRD for your selected satellite TV service

2 Installation

TracVision S3 is designed for simple installation and setup. Just follow these easy steps:

| Step | Refer to Section... |
|-------------------------------------|---------------------|
| 1. Choose the hardware locations | 2.1 |
| 2. Mount the antenna unit | 2.2 |
| 3. Connect system components | 2.3 |
| 4. Activate the IRD | 2.4 |
| 5. Select active satellite | 2.5 |
| 6. Set the skew angle (Europe only) | 2.6 |
| 7. Check out system | 2.7 |
| 8. Configure for remote dish use | 2.8 |

Table 2-1
Installation Process



Plan the entire installation before proceeding! Take into account component placement, cable running distances between units, and accessibility to the equipment after installation.

Installation Tools and Materials Required

- Electric drill
- $\frac{3}{16}$ " (5 mm), $\frac{5}{32}$ " (4 mm), and $\frac{3}{32}$ " (2.5 mm) drill bits and $\frac{3}{4}$ " (19 mm) hole saw and auger bit
- $\frac{1}{2}$ " wrench
- #2 Phillips and #0 flat tip screwdrivers
- RG-6 or RG-11 (75 ohms) RF cable (if installing two RF cables - refer to [Section 2.3.5](#) for details)
- Silicone sealant, RTV, or Sikaflex
- $\frac{7}{16}$ " open end wrench
- Construction adhesive (e.g., Liquid Nails)
- Rivet gun and $\frac{3}{16}$ " (5 mm) rivets (or other fastener suitable for your specific roof construction)
- PC with terminal emulation software such as PROCOMM or Windows Terminal or Hyperterminal

Kitpack Contents

Table 2-2 lists the materials provided in the TracVision S3 kitpack.

Table 2-2
Kitpack Contents

| Part | Qty. | KVH Part No. |
|---|-------------|---------------------|
| Tie-wraps | 5 | 22-0013 |
| Clamshell ventilator | 1 | 19-0230 |
| #6 x $\frac{3}{4}$ " thread-forming screws | 3 | 14-0298-12 |
| $\frac{1}{4}$ "-20 x $\frac{5}{8}$ " hex screws | 4 | 14-0250-0010 |
| $\frac{1}{4}$ " flat washers | 4 | 14-0251 |
| Switchplate bulb assembly (spare) | 1 | 19-0193 |

2.1 Choosing the Best Location

- Since the TracVision antenna requires a clear view of the southern sky to receive satellite signals, the ideal antenna site has an unobstructed view of the horizon/satellite all around.
- Keep the antenna clear of any obstructions on the roof (e.g., air conditioners). The antenna requires a 15° to 75° look angle to receive satellite signals.

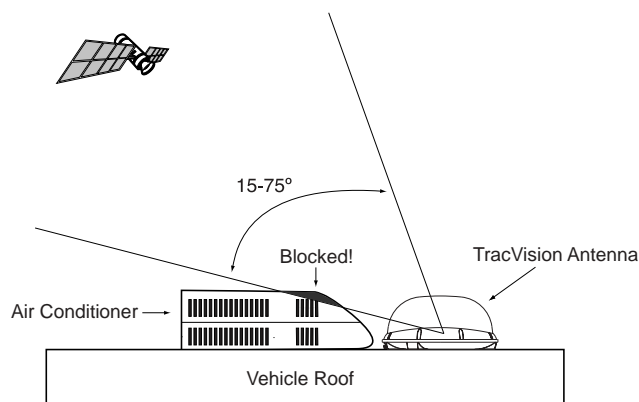

Figure 2-1
Antenna Blockage

- Consider the location of the antenna relative to the location of any equipment or necessary wiring within the vehicle.
- Be sure to mount the antenna on a horizontal surface. When placed flat on the mounting surface, the mounting plates should be less than $\frac{7}{16}$ " above the mounting surface (see Figure 2-2). **Any larger gap will warp the baseplate and seriously damage the antenna.**

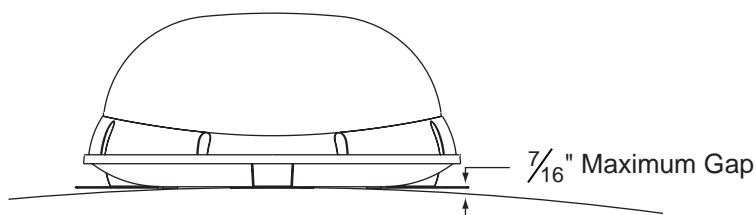

Figure 2-2
Maximum Mounting Surface Slope



Always lift the antenna unit by the gray baseplate, never by the radome or any portion of the antenna assembly!

2.2 Mounting the Antenna Unit

1. Make sure that you have chosen a suitable mounting location based upon the guidelines in [Section 2.1, "Choosing the Best Location."](#)
2. Remove the antenna unit from its shipping carton.
3. Position the antenna unit in the desired location on the centerline of the vehicle with the antenna's mounting plate arrows facing the front or rear of the vehicle. The proper orientation is illustrated in Figure 2-3.

Figure 2-3
Proper Orientation of the Antenna Unit

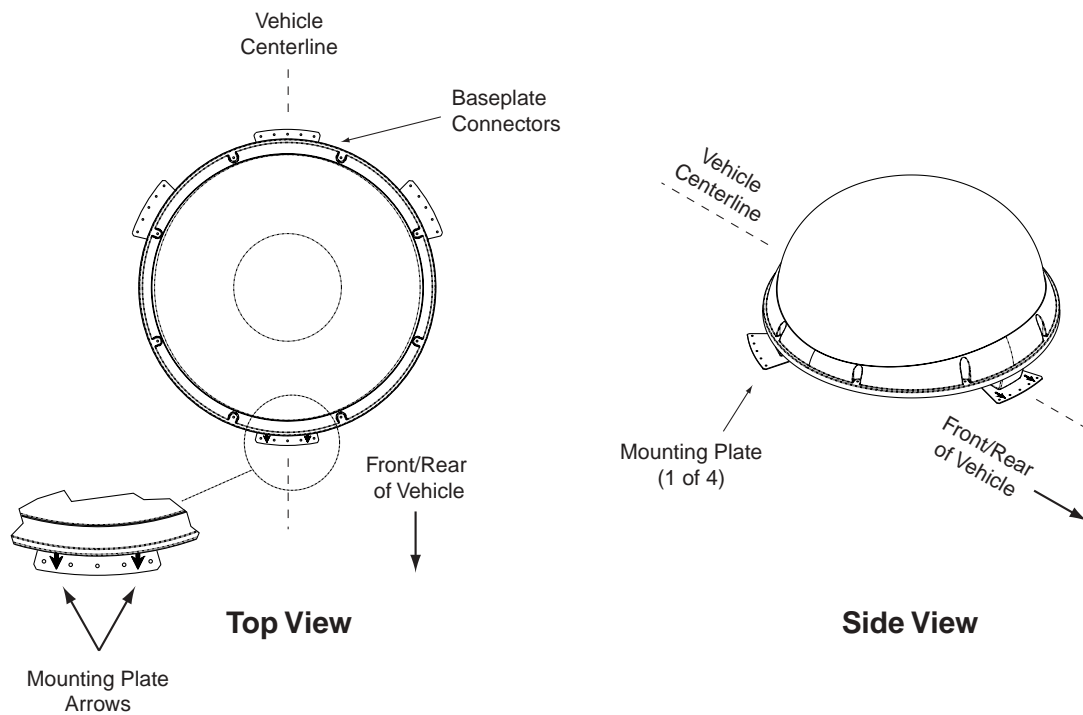

The mounting plate arrows may face either forward or backward along the centerline of the vehicle for more convenient installation.

4. While the antenna is in place, mark a location on the roof for the $\frac{3}{4}$ " (19 mm) cable access hole to permit convenient cable access to the antenna's baseplate connectors.
5. Using the 4 mounting plates and each set of 5 holes as templates, drill 20 $\frac{3}{16}$ " (5 mm) holes through the roof of the vehicle.
6. Set aside the antenna unit and clean the roof's surface to remove any debris.
7. Apply construction adhesive to the bottom of the antenna's four mounting plates. If using a liquid construction adhesive, apply beads to the mounting plates in a zig-zag pattern.

8. Reposition the antenna, lining up the mounting plate holes with the holes in the roof. Attach the mounting plates to the roof using $\frac{3}{16}$ " (5 mm)-diameter rivets (or appropriate fasteners). Seal all rivet heads and edges with silicone.
9. Remove and save the 8 pan head screws and flat washers that secure the radome to the baseplate. Carefully lift the radome straight up until clear of the antenna assembly and set aside.
10. When the antenna unit is installed with the connectors facing the rear of the vehicle, the drain holes are located as shown in Figure 2-4.



If the roof's mounting surface is not perfectly flat as KVH recommends, make sure the baseplate does not warp when you attach the antenna's mounting plates. Refer to Section 2.1, "Choosing the Best Location," for further details.

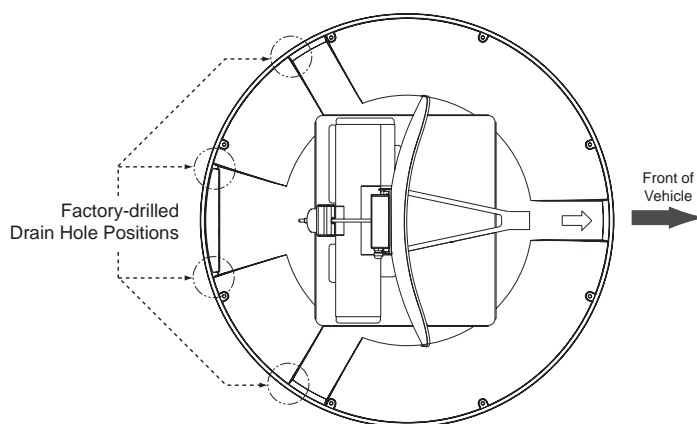

Figure 2-4
Baseplate Connectors Facing Rear of Vehicle – Factory-drilled Drain Hole Locations

10a. (Alternate Drain Hole Locations) If the antenna unit is installed with the connectors facing the front of the vehicle, drill out $\frac{3}{16}$ " (5 mm)-drain holes in the rear-facing side of the baseplate as illustrated in Figure 2-5. The existing factory-drilled drain holes shown in Figure 2-4 must then be plugged with silicone rubber sealant.

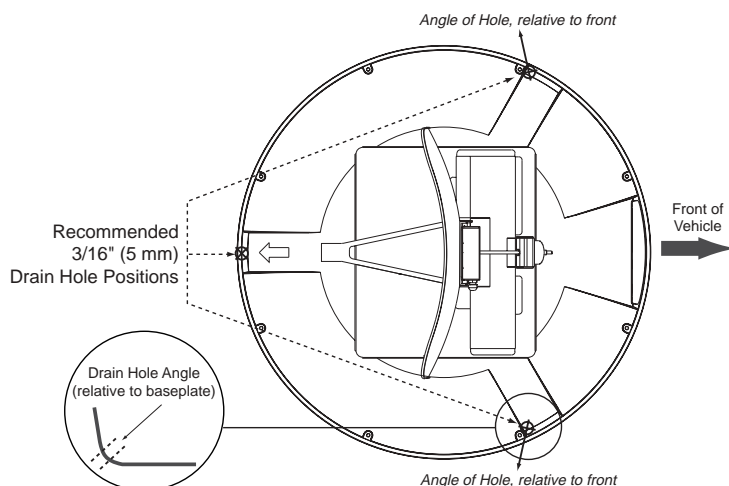

Figure 2-5
Baseplate Connectors Facing Front of Vehicle – Recommended Drain Hole Locations



You **MUST** drill out the drain holes as indicated to ensure that any moisture that enters the baseplate is able to drain. Ensure that factory-drilled holes are completely sealed.

- Cut the tie-wraps holding the antenna unit to the forward shipping restraint (see Figure 2-6).

Figure 2-6
Forward Shipping Restraint
(Arranged for Shipping)

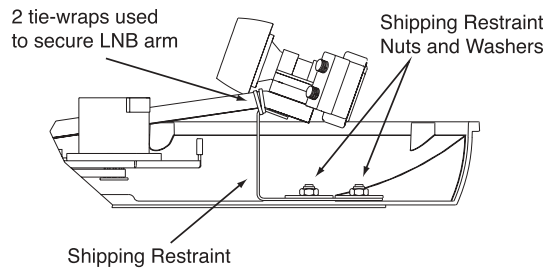

- Remove the nuts and washers securing the shipping restraints to the baseplate. The positions of all three shipping restraints are pictured in Figure 2-7.

Figure 2-7
TracVision S3 Shipping Restraints
(Top View, Installed for Shipping)



Do not discard the shipping restraints, washers, or the nuts. They should be stowed for future use in case the antenna unit needs to be removed and shipped to another location. Four ¼" x ⅝" hex head screws have been provided in the kitpack for shipping as the bolts used to hold the shipping restraints during initial shipping are integral parts of the mounting plates.

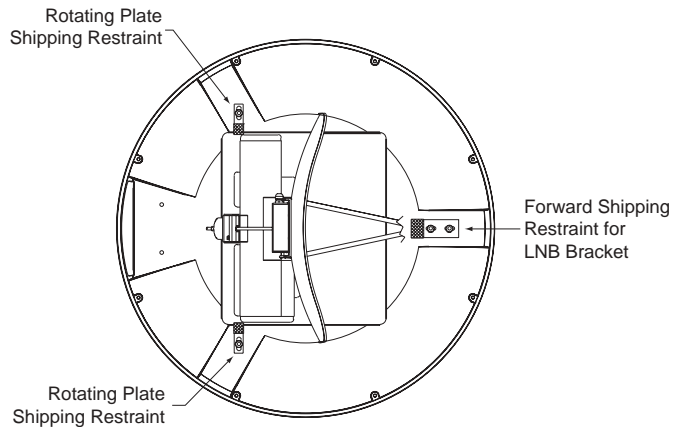

- For convenient storage, rotate the shipping restraints 180° and secure them to their original mounting bolts using the nuts and washers removed in Step 12 (see Figures 2-8 through 2-10). **All nuts and washers removed in Step 12 must be reinstalled. These nuts and washers secure the baseplate to the mounting plates.**

Figure 2-8
Forward Shipping Restraint Storage

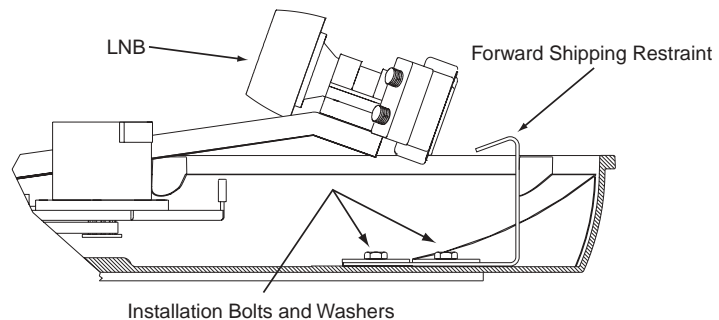

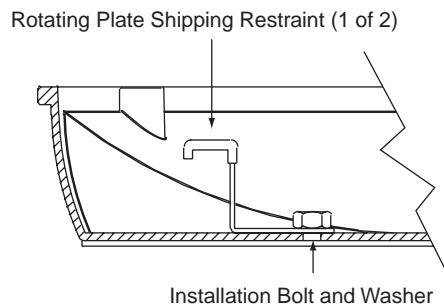

Figure 2-9
Rotating Plate Shipping
Restraint Storage

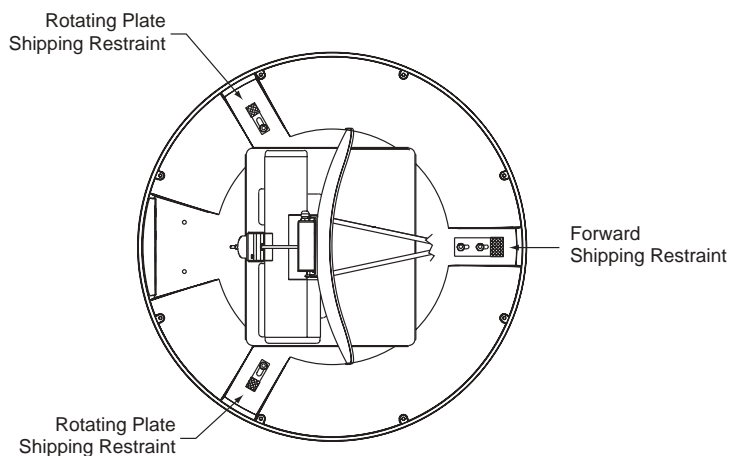

Figure 2-10
TracVision S3 Shipping Restraints
(Storage Position)

14. Place the radome onto the baseplate (labels facing the sides of the vehicle) and secure in place using the 8 pan head screws and flat washers removed in Step 9.
15. Drill the cable access hole (marked in Step 4) in the vehicle's roof.

2.3 Connecting System Components

The following sections provide instructions for properly wiring the antenna unit to the components inside the vehicle.

Locating the Switchplate

A switchplate has been provided to serve as the hub of the TracVision S3 wiring (with the exception of the RF cable, which will be connected to the IRD). This switchplate includes an ON/OFF switch and a DB9 maintenance port for easy access to the antenna unit's software and diagnostics. Follow the steps below to select and prepare the switchplate mounting location.

1. Select a location to mount the TracVision S3 switchplate. It should be installed in a dry, flat location within reach of the cables that will connect to the antenna unit.
2. Once you've decided on a suitable location, create a panel cutout in the mounting surface. Figure 2-11 illustrates the mounting dimensions and a template has been provided in [Appendix C](#). The connecting cables will be routed through this cutout.

Figure 2-11
Switchplate Panel
Cutout Dimensions



A full-scale panel cutout template has been provided in [Appendix C](#).

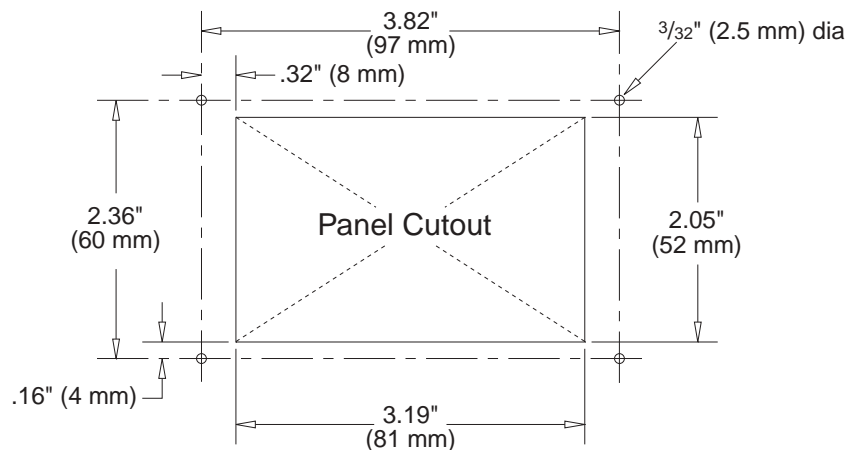

2.3.1 Connecting the Antenna Data/Power Cable

1. Connect one end of the antenna data/power cable to the antenna's data/power connector and lock in place (see Figure 2-12).

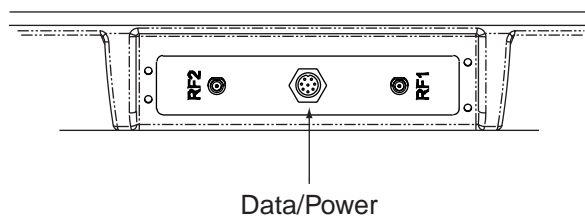

Figure 2-12
Antenna Data/Power Connector

2. Route the other end of the data/power cable down through the cable access hole in the vehicle's roof and out through the switchplate panel cutout.
3. Connect the data/power cable to the switchplate's data/power connector and lock in place (see Figure 2-13).

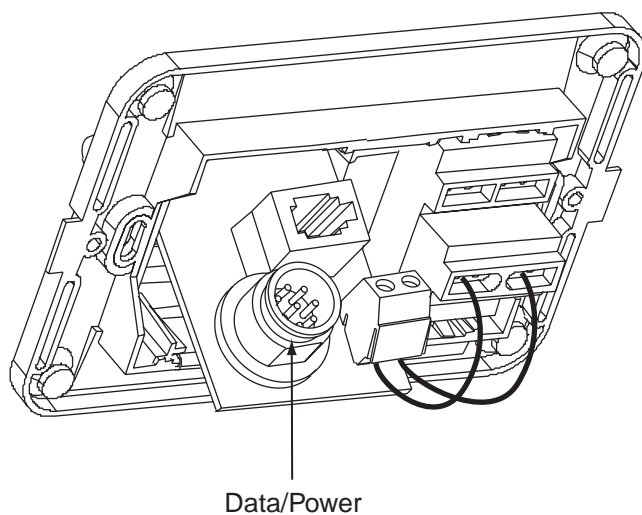

Figure 2-13
Switchplate Data/Power Connector

2.3.2 Connecting to Vehicle Power

Recommended Power Wiring

Short circuits may result in severe electrical shock or burns. Remove the appropriate vehicle fuse and test the circuit to ensure that no power is present before connecting the power cable.

The switchplate requires an 11-16 VDC power input. A quick-tripping circuit breaker or fuse should be installed between the switchplate and vehicle power. Circuit overload protection should be rated for 5 amperes. If vehicle power fluctuates widely or is noisy, a 12 VDC 5-amp AC/DC power supply or a wide-range DC/DC converter power supply should be installed. *Test the voltage and polarity before making connections to vehicle power.*



Before connecting the antenna unit to vehicle power, remove the appropriate vehicle fuse to prevent a short circuit.

Connecting the Power Cable to the Switchplate

1. Disconnect vehicle power by removing the appropriate vehicle fuse.
2. Connect the switchplate to vehicle power as pictured in Figure 2-14.

Figure 2-14
Switchplate Power Wiring

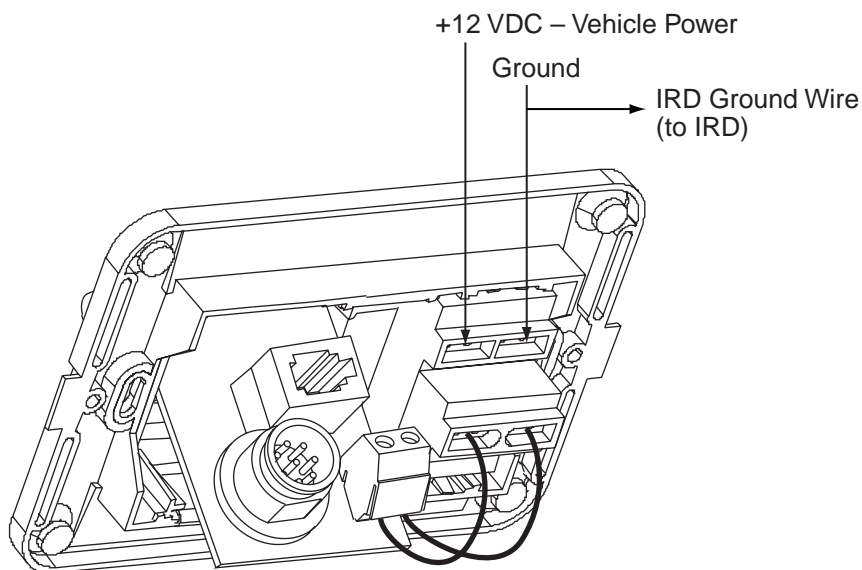

2.3.3 Connecting the IRD Ground Wire

A grounding wire (Cable #32-0583-50) has been provided to connect your IRD to a suitable ground and protect the system. Attach the grounding wire to any suitable screw on the rear panel of the IRD with a good contact with the IRD chassis. The other end should be connected to a suitable ground, ideally the ground connector on the switchplate (see Figure 2-14).

2.3.4 Installing the Switchplate

After completing the switchplate wiring process, you must install the switchplate itself. This process, detailed in the following steps, is illustrated in Figure 2-15.

Figure 2-15
Mounting the Switchplate
Support Frame and Front Cover

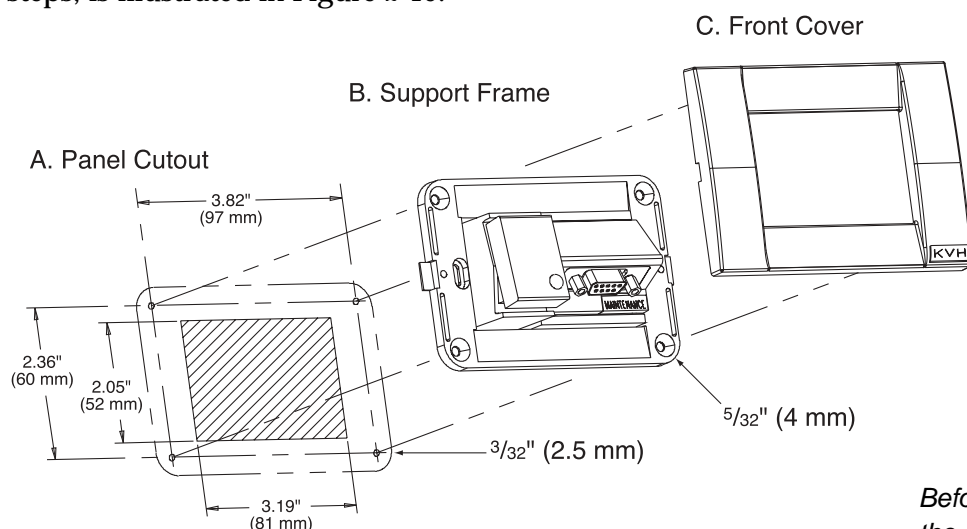

1. Fit the switchplate assembly and support frame into the panel cutout made in Step 2 of [Section 2.3, "Connecting System Components,"](#) and flush to the mounting surface.
2. Drill out four $\frac{5}{32}$ " (4 mm) holes in the countersunk settings in the switchplate support frame.
3. Drill four $\frac{3}{32}$ " (2.5 mm) holes in the mounting surface using the countersunk holes in the support frame as the template. Secure the support frame and switchplate assembly to the mounting surface using four #6 self-cutting screws.
4. Snap the front cover into place to cover the screws and support frame.
5. Reinstall the vehicle fuse removed in Step 1 of [Section 2.3.2, "Connecting to Vehicle Power."](#)

Before securing the switchplate to the mounting surface, be sure to strain-relieve the wires connecting to the switchplate connectors. Several tie-wraps have been provided to aid in strain-relieving the wires.



When shipped from the factory, the antenna's RF connectors are protected with caps. Leave the cap installed on the RF2 connector unless you are going to connect a second RF cable to the TracVision S3.

Figure 2-16
Antenna RF Connectors

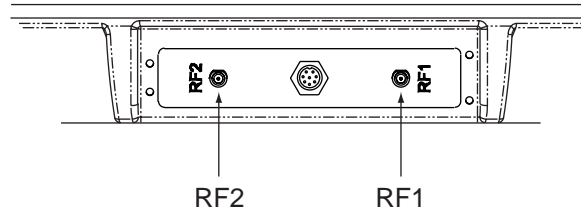

2.3.5 Connecting the Antenna RF Signal Cable to the IRD

1. Route an RF cable up through the roof's cable access hole.
2. Connect the RF cable to the antenna's RF1 connector (see Figure 2-16). Once the cable is securely connected, loosen the sealing nut at the base of the RF1 connector and tighten it onto the end of the RF cable.

3. Connect the other end of the RF cable to the IRD's SATELLITE IN connector.



KVH recommends the use of RG-6 or RG-11 (75 ohms) cable for RF wiring. Use of non-RG-6 or RG-11 (75 ohms) cables will result in degraded performance. The KVH warranty does not cover degraded performance due to improper wiring.

2.3.5.1 Installing Two IRDs and TVs (North American Systems Only)

To connect a second TV and IRD to the TracVision S3 system, you must connect a second RF cable to the antenna's RF2 connector (see Figure 2-16). Route the other end of the RF cable down into the vehicle and connect it directly to the second IRD.

2.3.5.2 Connecting Three or More IRDs and TVs (North American Systems Only)

To install three or more IRD/TV pairs, an active multiswitch (Channel Master model 6214IFD or equivalent) must be placed between the antenna unit and the IRDs. Figure 2-17 illustrates typical wiring arrangements for multiple IRDs. If more than four IRDs are required, contact KVH for additional wiring instructions. Mount the multiswitch unit in accordance with the manufacturer's instruction sheet.

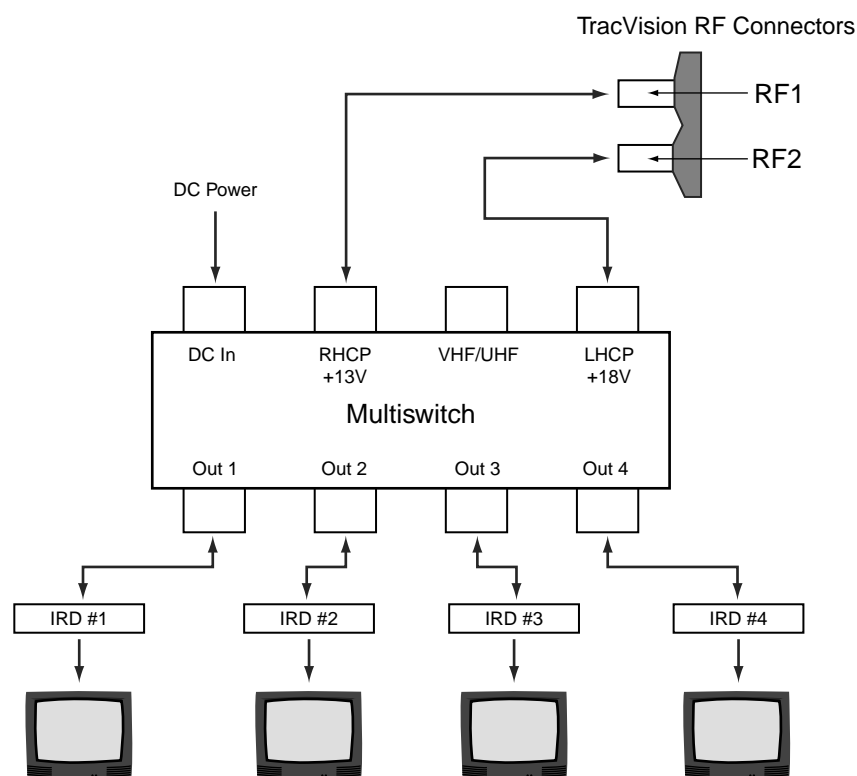

1. Connect the RF cable tagged "RF1" to the multiswitch input labeled "LNB RHCP +13V."
2. Connect a second RF cable to the multiswitch input labeled "LNB LHCP +18V."
3. Connect the multiswitch outputs to individual IRD inputs. Use RG-6 cable terminated with F-type connectors for all RF connections.
4. Terminate all unused output connectors with 75 ohm DC blocks (Channel Master #7184, Radio Shack #15-1259 or equivalent).

Figure 2-17
Installing Three or Four IRDs
Using an Active Multiswitch



TracVision S3 has the capability to switch from one satellite to another when you choose TV channels that are carried by your two selected satellites. However, the use of an active multiswitch may interfere with the 22 KHz tone sent by DIRECTV DSS Plus™ IRDs to the antenna. As a result, the antenna may not receive the signal to change satellites when you change channels using your DIRECTV DSS Plus remote.

In this case, you will need to use the optional TV/SAT Switch or a PC as described in Section 3.2, "Changing Channels and Switching Between Satellites."*

** To order a TV/SAT Switch (KVH Part Number 01-0245), please call +1 401 847-3327.*

2.3.6 Sealing the Cable Access Hole

Once the RF and data/power cables are connected to the antenna, you need to seal and cover the cable access hole to protect against leakage.

1. Completely seal the cable access hole with silicone sealant or RTV.
2. Install the clamshell ventilator, supplied in the kitpack, over the cable access hole using the three supplied #6 screws (see Figure 2-18).

Figure 2-18
Installing the Clamshell Ventilator



Ensure the clamshell mounting screws do not puncture the cables inside the vehicle.

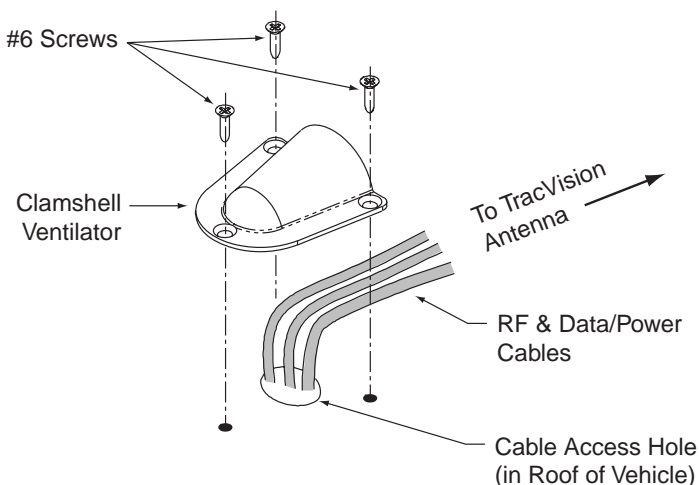

2.4 Activating the IRD

DIRECTV and DISH Network IRD Activation

KVH makes it easy to activate your DIRECTV or EchoStar (DISH Network) IRD. Just call KVH at 1-888-584-4163 and ask for **IRD Activation** (Monday - Friday, 8:30 a.m. - 5:00 p.m. EST). For other options, please refer to the user manual that accompanied your IRD.

Other IRD Activations

Please refer to the user manual that accompanied your IRD for activation instructions.

2.5 Selecting the Active Satellite

As noted previously, TracVision S3 can track a variety of DVB-compatible and DSS (DIRECTV) satellites. The system contains a preprogrammed library of European and North American satellites. It also has two open slots that you may use to program two additional satellites of your choice. Tables 2-3 and 2-4 provide a grid of possible satellite pairs. Two of these satellites may be selected to reside in the system's active memory as Satellites A and B.

Table 2-3
Available European Satellite Pairs
(European LNB Required)

| | Astra 1 | Astra 2N | Astra 2S | Hispasat | Hotbird | Sirius | Thor |
|----------|---------|----------|----------|----------|---------|--------|------|
| Astra 1 | | ✓ | ✓ | | ✓ | ✓ | |
| Astra 2N | ✓ | | | | ✓ | | |
| Astra 2S | ✓ | | | | ✓ | | |
| Hispasat | | | | | | | |
| Hotbird | ✓ | ✓ | ✓ | | | ✓ | |
| Sirius | ✓ | | | | ✓ | | ✓ |
| Thor | | | | | | ✓ | |

Table 2-4
Available N. American Satellite
Pairs (U.S.-style LNB Required)

| | DSS_101 | DSS_119 | Echo_61 | Echo_110 | Echo_119 | Echo_148 | Expressvu |
|-----------|---------|---------|---------|----------|----------|----------|-----------|
| DSS_101 | | ✓ | | | | | |
| DSS_119 | ✓ | | | | | | |
| Echo_61 | | | | ✓ | ✓ | | ✓ |
| Echo_110 | | | ✓ | | ✓ | ✓ | ✓ |
| Echo_119 | | | ✓ | ✓ | | ✓ | ✓ |
| Echo_148 | | | | ✓ | ✓ | | ✓ |
| Expressvu | | | ✓ | ✓ | ✓ | ✓ | |



To receive DISH 500 service, you will need to install the following two satellites:

Echo_119 & Echo_110



The satellite configuration on your IRD must match the satellite setting on the TracVision S3 system.

Satellite A on the TracVision S3 must be the same satellite as IRD Alternative 1 (or A, based on your IRD) and must be assigned the IRD DiSEqC 1 setting.*

Satellite B on the TracVision S3 must be the same satellite as IRD Alternative 2 (or B, based on your IRD) and must be assigned the IRD DiSEqC 2 setting.*

Refer to your IRD user manual for complete instructions for your IRD.

* DiSEqC settings apply only to European systems.

The satellites listed in TracVision S3's preprogrammed satellite library will be sufficient for most users. However, if you wish to install one or two user-defined satellites, proceed to [Section 2.5.2, "Programming User-defined Satellites."](#) After configuring the user-defined satellites, return to the satellite installation process in [Section 2.5.1, "Installing Your Selected Satellites."](#)

2.5.1 Installing Your Selected Satellites

When you first connect to the system, it is programmed with the factory default satellite assignments:

- Europe: Astra 1 (Sat. A) and Hotbird (Sat. B)
- N. America (ExpressVu): Expressvu (Sat. A) and None (Sat. B)
- N. America (US DISH Network): Echo_119 (Sat A) and None (Sat B)
- N. America (US DIRECTV): DSS_101 (Sat A) and DSS_119 (Sat B)

Should you wish to track a different satellite (either from the satellite library or a user-defined satellite), you must instruct the antenna which satellites will be in the active satellite pair.

Connecting to the TracVision S3 Maintenance Port

To do so, it is necessary to connect a PC to the terminal maintenance port on the switchplate. The diagnostics procedure requires terminal emulation software such as PROCOMM or Windows Terminal or Hyperterminal. Use the settings appropriate to your application.

1. Connect one end of the PC data cable to the DB9 connector on the switchplate. Connect the other end to the serial port on the PC (a 9-pin/25-pin connector adapter may be needed for some PCs).
2. Open the terminal emulation software and establish the following settings:
 - 9600 baud
 - no parity
 - 8 data bits
 - 1 start bit
 - 1 stop bit
 - no flow control

- Apply power to the TracVision S3 system and allow the system to complete full initialization. Data should be scrolling on the PC display to identify any system problems detected. If no data is seen, recheck your connections and the terminal software setup.

Installing the Satellite of Choice

Once the data connection has been made between the PC and the TracVision S3, you must assign the satellites you wish to have in the satellite pair. On the maintenance screen, put the antenna in Idle Mode by typing **HALT**, then enter the SATINSTALL command:

Command: **SATINSTALL,<sat_a_name>,<sat_b_name><cr>**
(*<cr>* indicates a carriage return/ENTER key)

| | |
|--------|--|
| Where: | <sat_a_name> = the name of your choice for Satellite A <sat_b_name> = the name of your choice for Satellite B |
|--------|--|

Table 2-5 lists the assigned names for satellites that are in the preprogrammed European and North American satellite library. If you do not wish to assign a pair of satellites, enter **None** as the name of Satellite B.

After you have assigned satellites as Satellites A and B, the final step is to tell the antenna which of the two satellites it should acquire and track. This step should be carried out the first time a satellite is selected, allowing the system to carry out the initial download of the channel guide. To do so, enter the Satellite Selection parser command as follows:

Command: **@L,x<cr>**

| | |
|--------|---|
| Where: | x = A or B (one of your selected satellites as defined during the SATINSTALL process) |
|--------|---|

Choosing A or B will assign the antenna to acquire and track that installed satellite. To complete the process, type **ZAP<cr>** to restart the system. Be sure the IRD satellite configuration matches your chosen TracVision S3 settings.

Table 2-5
Satellite Installation Names

| Satellite | Install Name |
|--|--------------|
| European Satellites | |
| ASTRA1 19.2°E | ASTRA1 |
| ASTRA2N 28.2°E | ASTRA2N |
| ASTRA2S 28.2°E | ASTRA2S |
| Hispasat 30.0°W | HISPASAT |
| Hotbird 13.0°E | HOTBIRD |
| Sirius 5.0°E | SIRIUS |
| Thor 0.8°W | THOR |
| North American Satellites | |
| DSS 101° W | DSS_101 |
| DSS 119°W | DSS_119 |
| EchoStar 61°W | Echo_61 |
| EchoStar 110°W | Echo_110 |
| EchoStar 119°W | Echo_119 |
| EchoStar 148°W | Echo_148 |
| ExpressVu | Expressvu |
| Other Installation Designations | |
| User-defined 1 | USER1* |
| User-defined 2 | USER2* |
| None | None |

* *USER1 and USER2 will only be available if one or two user-defined satellites have been added to the library as detailed in [Section 2.5.2](#), "Programming User-defined Satellites."*

For example, to assign Astra 2S and Hotbird for your satellite pair, and to track Astra 2S, you would enter the following data:

```
SATINSTALL,ASTRA2S,HOTBIRD<cr>
```

```
@L,A<cr>
```

```
ZAP<cr>
```

2.5.2 Programming User-defined Satellites

The TracVision S3 satellite library has two open slots that you may use to program two user-defined satellites in case you want to install/watch a satellite that is not in the KVH predefined list. To configure a user satellite, the system must first be in Idle Mode (by typing **HALT**) and then information about the satellite must be provided, including:

- Satellite name
- Satellite position (longitude)
- Transponder information for each of the following polarizations/frequencies:
 - vertical high & vertical low
 - horizontal high & horizontal low

or

 - right
 - left
- Transponder information includes:
 - frequency
 - symbol rate
 - FEC code, and
 - network ID (in hexadecimal format)
- Decoder type



For your reference, the satellite configuration information for the predefined satellites is available on our web site at www.kvh.com/footprint/index.html.

This information can be obtained from your satellite service provider or from sites on the Internet, such as www.satcodx.com.

Entering User-defined Satellite Data

Once the link between the PC and the TracVision S3 is established as described in [Section 2.5, "Selecting the Active Satellite,"](#) you need to provide initial longitude data regarding the user-defined satellite. To do so, enter the SATCONFIG parser command via PC as follows:

| | |
|-----------|---|
| Command: | SATCONFIG,USERX,YYY,Z,D,L<cr> (<i><cr></i> indicates a carriage return/ENTER key) |
| Where: | X = 1 or 2 (satellite alternative) YYY = longitude (0-180) Z = E (East) or W (West) D = decoding type (0 = test, 1 = DSS-A, 2 = DSS-B, 3 = DVB) L = LNB polarization (C = circular, L = linear) |
| Function: | configures one of the user-configurable satellites with the longitude provided |
| Response: | if valid entry, echoes the input data if invalid entry, returns error message |

After entering the SATCONFIG command, you must turn on the DEBUG mode by typing **@DEBUGON**. Following the entry of the SATCONFIG and DEBUGON commands, enter the satellite transponder information via PC as follows:

| | |
|----------|---|
| Command: | @SATCONFIG,X,N,F,S,C,ID,P,B,D<cr> |
| Where: | @SATCONFIG = directs data to the RF Board X = satellite location A or B N = satellite table # (98 & 99 are slots for user-configured satellites) F = frequency in MHz (either 00000 or a range from 10700 - 12700) S = the satellite transponder symbol rate in Mbit/second (01000 - 29999) C = the FEC code (e.g., 12, 23, 34, 56, 67, 78) ID = the satellite network ID in hexadecimal format (0x####) P = the LNB polarization (v = vertical, h = horizontal, r = right, l = left) B = the LNB down conversion frequency (l = low, h = high, u = USA) D = decoding type (0 = test, 1 = DSS-A, 2 = DSS-B, 3 = DVB) |

This information has to be entered for each of the following transponder categories:

- vertical high
- horizontal high
- vertical low
- horizontal low

or

- right
- left

TracVision S3 requires that the data fields for all transponder categories be provided. If the selected satellite does not have information for one or more of the transponder categories, default information should be entered in the fields as follows:

Table 2-6
Default Transponder Values

| Transponder Data | Default Value |
|-------------------------|---|
| Frequency | 00000 |
| Symbol Rate | 27500 |
| FEC Code | the same value as provided for those transponders with data |
| Network ID | 0x0000 |
| Polarity and Band | whichever combinations are not already provided |

After entering this information, it is necessary to save these settings. To do so, type:

@SAVE,A (or **@SAVE,B** if data is for User2 satellite)

@DEBUGOFF

After completing this process, restart the system by either cycling power or typing **ZAP**.

One of your user-defined satellite options has now been added to the TracVision S3 satellite library. This option will now be available the next time the SATINSTALL command is given.

An Example of Configuring a User-defined Satellite (Europe)

The following is an example of configuring the fictional YOURSAT 101 as the USER1 configured satellite. Prior to configuring this satellite or any others, be certain to get the most up-to-date information from one of the sources previously discussed.

YOURSAT 101 at 7 West, DVB decoder, Linear Polarization LNB

| | |
|------------------------|---------------------|
| <i>Horizontal High</i> | |
| Frequency | 11.966 GHz |
| Symbol Rate | 27500 |
| FEC Code | 3/4 |
| Network ID | 2048 (dec) = 0x0800 |
| <i>Vertical High</i> | |
| Frequency | 11.823 GHz |
| Symbol Rate | 27500 |
| FEC Code | 3/4 |
| Network ID | 2048(dec) = 0x0800 |
| <i>Vertical Low</i> | |
| No Data Listed | |
| <i>Horizontal Low</i> | |
| No Data Listed | |

Table 2-7

*Sample User-defined
Satellite Configuration (Europe)*

Based on this information, the data entered via the PC would look like this, assuming that YOURSAT 101 would be Satellite A:

```
SATCONFIG,USER1,7,W,3,L
@DEBUGON
@SATCONFIG,A,98,11966,27500,34,0x0800,H,H,3
@SATCONFIG,A,98,11823,27500,34,0x0800,V,H,3
@SATCONFIG,A,98,00000,27500,34,0x0000,V,L,3
@SATCONFIG,A,98,00000,27500,34,0x0000,H,L,3
@SAVE,A
@DEBUGOFF
ZAP
```

An Example of Configuring a User-defined Satellite (N. America)

The following is an example of configuring the fictional YOURSAT 101 as the USER1 configured satellite. Prior to configuring this satellite or any others, be certain to get the most up-to-date information from one of the sources previously discussed.

Table 2-8
*Sample User-defined
 Satellite Configuration
 (N. America)*

YOURSAT 101 at 71 West, DVB decoder, Circular Polarization LNB

| | |
|--------------|---------------------|
| <i>Right</i> | |
| Frequency | 11.966 GHz |
| Symbol Rate | 27500 |
| FEC Code | 3/4 |
| Network ID | 2048 (dec) = 0x0800 |
| <i>Left</i> | |
| Frequency | 11.823 GHz |
| Symbol Rate | 27500 |
| FEC Code | 3/4 |
| Network ID | 2048(dec) = 0x0800 |

Based on this information, the data entered via the PC would look like this, assuming that YOURSAT 101 would be Satellite A:

```
SATCONFIG,USER1,71,W,3,C
@DEBUGON
@SATCONFIG,A,98,11966,27500,34,0x0800,R,U,3
@SATCONFIG,A,98,11823,27500,34,0x0800,L,U,3
@SAVE,A
@DEBUGOFF
ZAP
```

2.6 Setting the Skew Angle (European Systems Only)

The Antenna LNB skew angle must be adjusted to optimize channel reception. Refer to your satellite service provider for the proper skew angle for the selected satellite service and geographical location. The skew angle for KVH predefined satellites can also be obtained by using a PC connected to the maintenance port. Enter your latitude and longitude using the GPS command (refer to [Appendix E.6](#) for details) and then type **SKEWANGLE**. The system will respond with the skew angle for whichever satellite is currently selected.

Adjusting the LNB Skew Angle

1. Determine the skew angle for the selected satellite and region.
2. Loosen the wing nut on the LNB clamp so that the LNB can be moved.
3. Carefully rotate the LNB so that the scribe mark on the LNB clamp is aligned with the proper angle measurement.
4. Tighten the wing nut and LNB clamp to secure the LNB.

Figure 2-19
Skew Adjustment (European Systems Only)

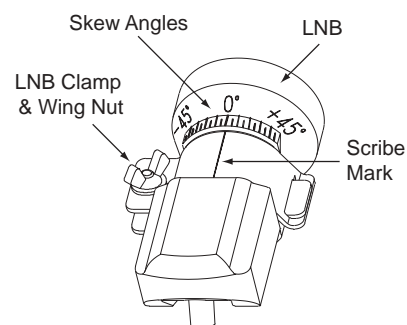

2.7 Checking Out the System

To complete the TracVision S3 installation, it will be necessary to verify that the system functions properly. Critical to ensuring that the system is configured and operating properly is to check the system startup routine to ensure that the system is operating within normal parameters.

To do so, it is necessary to connect a PC to the terminal maintenance port. The diagnostics procedure requires terminal emulation software such as PROCOMM or Windows Terminal or Hyperterminal. Use the settings appropriate to your application.

1. Connect one end of the PC data cable to the DB9 connector on the switchplate. Connect the other end to the serial port on the PC (a 9-pin/25-pin connector adapter may be needed for some PCs).

2. Open the terminal emulation software and establish the following settings:
 - 9600 baud
 - no parity
 - 8 data bits
 - 1 start bit
 - 1 stop bit
 - no flow control
3. Apply power to the TracVision S3 system and the IRD and allow the system to complete full initialization. Data should be scrolling on the PC display to identify any system problems detected. If no data is seen, recheck your connections and the terminal software setup. *A sample startup sequence has been provided in [Appendix D](#).*
4. After completing the review of the startup and operational routines, turn on the IRD and television and check the channels on the selected satellites. For European systems, view both horizontally and vertically polarized channels, if possible.
5. When all checks are completed, shut down the system.



*If a need arises to paint the radome, **ONLY use non-metallic automotive paint** to avoid degrading the RF signal strength and the reception quality.*

2.8 Configuring TracVision S3 for Remote Satellite Dish Operation

In some campground locations, dense foliage will block the satellite signal. In these situations, a remote portable antenna may be the only solution to satellite signal reception.

The wiring option for the remote dish is very simple and should be installed when the TracVision S3 is installed. A high-quality “A/B switch” should be used to change from TracVision S3 dish reception to remote antenna operation. The recommended wiring arrangement for remote dish operation is illustrated in Figure 2-20.

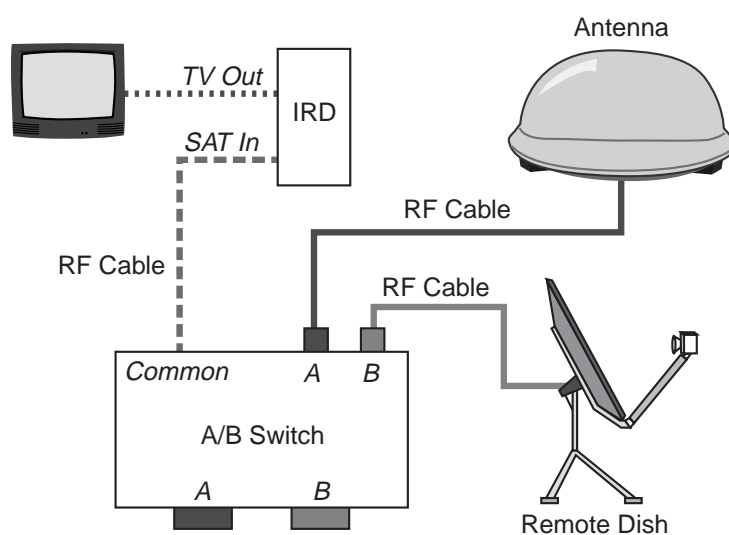

Figure 2-20
Remote Dish Wiring Configuration

2.9 Changing Geographic Location

If you move from Europe to the U.S., or from the U.S. to Europe, you will need to modify your TracVision S3 system to receive satellite TV signals in the new geographic area.

To begin receiving satellite signals in the new area, perform the following steps.

Swap LNBS

To receive the proper satellite signals in the new geographic location, your TracVision antenna must be equipped with the appropriate LNB for that location. If moving from Europe to the U.S., you will need to install a North American-style LNB. If moving from the U.S. to Europe, you will need to install a European-style LNB. Table 2-9 lists the part numbers for ordering these LNB options.

Table 2-9
LNB Part Numbers

| Part Name | Part Number |
|--------------------------|-------------|
| European-style LNB | 19-0196 |
| North American-style LNB | 19-0056 |

With the new part, you will receive an easy-to-understand instruction sheet for swapping the LNBS.

Install New Satellites

When you move to a new area, the list of available satellites changes. If you're moving to Europe, you will need to choose a new satellite pair from the list of available European satellites (see Table 2-3). If you're moving to the U.S., you will need to choose a new satellite pair from the list of available North American satellites (see Table 2-4). For details on installing these new satellites, refer to [Section 2.5.1, "Installing Your Selected Satellites."](#)



You may also need to replace your television when changing geographic location. In North America, your TV must support the NTSC video standard. In Europe, your TV must support the PAL video standard.

Replace the IRD

In order to receive satellite TV service in your new geographic location, you will need to purchase an IRD designed for that location. Refer to your satellite TV service provider for more information.

3 Using Your TracVision S3

For TracVision S3 to receive the satellite signals, the antenna must have a clear line of sight to the satellite. If you only receive intermittent signals or the antenna cannot find the satellite, check around your vehicle for any objects that could be blocking the signal, such as trees, buildings, etc.



Figure 3-1

Be Aware of Objects that Might Block the Satellite Signals



The TracVision S3 is for stationary use only. The system is not designed to track the satellite when the vehicle is moving.

You must also be located within the selected satellite's coverage area in order to receive its signal. Refer to your satellite television service manual to check the viable coverage area. *For your convenience, KVH provides links to several web sites that offer satellite coverage information. Simply go to our web site at: www.kvh.com/footprint/index.html.*



To minimize the time it takes the antenna to acquire the satellite, do not change the channel during the startup process or cable unwrap.

3.1 Turning On the System

The TracVision S3 system is easy to use. Antenna unit initialization and satellite acquisition are completely automatic.

To use the TracVision S3 system:

1. Park your vehicle.
2. Turn on the IRD and the television. (Refer to your IRD user manual for complete operating instructions.)
3. Turn on the antenna using the switchplate, as pictured in Figure 3-2.

Figure 3-2

Turning on the TracVision S3 Using the Switchplate

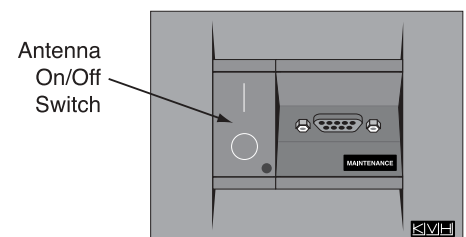

3.2 Changing Channels and Switching Between Satellites



If you are a **DISH 500** customer, you can order the optional TV/SAT Switch – **free of charge**. Simply fill out the order form located at the back of this manual and fax it to KVH at +1 401 845-8190.



The satellite configuration on your IRD must match the satellite setting on the TracVision S3 system.

*Satellite A on the TracVision S3 must be the same satellite as IRD Alternative 1 (or A, based on your IRD) and must be assigned the IRD DiSEqC 1 setting.**

*Satellite B on the TracVision S3 must be the same satellite as IRD Alternative 2 (or B, based on your IRD) and must be assigned the IRD DiSEqC 2 setting.**

Refer to your IRD user manual for complete instructions for your IRD.

** DiSEqC applies to European systems only.*

If you have followed the installation instructions, your system should be set to the active satellite pair of your choice and the system should have downloaded the appropriate channel guides. You must also have a properly configured IRD (if this has not been done, refer to your IRD User's Manual for instructions for your specific IRD).

Your TracVision system is programmed to track either of two satellites, stored in memory as Satellite A and Satellite B. You can use the IRD remote control, the optional TV/SAT Switch, or a PC to select between the two satellites.

3.2.1 Using the IRD Remote Control to Switch Between Satellites

When the TracVision S3 system and the IRD have matching configurations, switching from one satellite to the other is as easy as changing the channel using the remote control. TracVision S3 will automatically switch from Satellite A to B and back again as necessary to receive your selected channel.

DIRECTV Satellite Subscribers

DIRECTV subscribers in certain regions of the United States will require a DSS Plus IRD to receive both satellite and alternative programming. Check with DIRECTV for regional requirements.

If connected to the antenna's RF1 connector, the DSS Plus IRD allows you to switch channels using the remote control. If you are a DIRECTV subscriber, but do not have a DSS Plus IRD, or you are using a multiswitch, use the optional TV/SAT Switch* or a PC, as described in the following sections.

** To order a TV/SAT Switch (KVH Part Number 01-0245), please call +1 401 847-3327.*

EchoStar Satellite Subscribers

EchoStar subscribers will need to use the optional TV/SAT Switch or a PC to change satellites, as described in the following sections.

3.2.2 Using the TV/SAT Switch to Switch Between Satellites - *Optional*

If you are a DISH 500 customer, or you're unable to switch between satellites using the IRD remote control, you can use the optional TV/SAT Switch (see Figure 3-3) to easily select between Satellite A and Satellite B.

TV/SAT Switch Controls and Indicators

The Select button is used for all operator controls. The TV/SAT Switch also has three LED indicators that show its current status. Table 3-1 explains the function of each indicator.

| Indicator | Status | Meaning |
|-----------|----------------|--|
| Sat A | Blinking green | Wait – Searching for satellite |
| | Solid green | Tracking Satellite A |
| Error | Blinking red | System problem – Refer to Section 4, "Troubleshooting," to find the possible cause |
| Sat B | Blinking green | Wait – Searching for satellite |
| | Solid green | Tracking Satellite B |

Connecting the TV/SAT Switch

To use the TV/SAT Switch, you must first connect it to the TracVision system.

1. Connect the TV/SAT Switch's data cable to the maintenance port on the switchplate (see Figure 3-4).

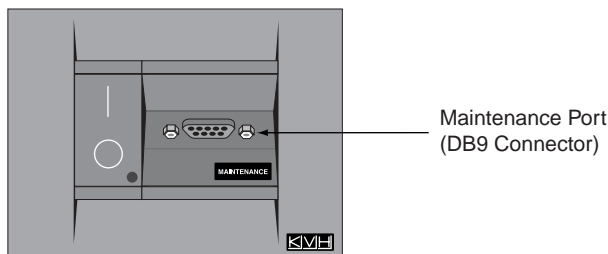

2. The Sat A and Sat B indicators blink while the system initializes.
3. Either the Sat A or Sat B indicator will turn solid green, denoting which satellite is currently being tracked.

Figure 3-3
TV/SAT Switch

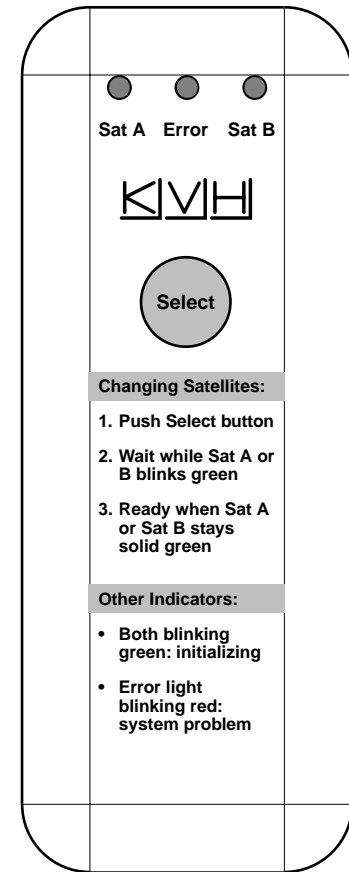

Table 3-1
TV/SAT Switch LED Indicators

Figure 3-4
Switchplate Maintenance Port

Using the TV/SAT Switch

The TV/SAT Switch is very easy to use. All operations are controlled through the single Select button.

To select the second satellite, perform the following steps:

1. Press the Select button on the TV/SAT Switch.
2. The indicator for the current satellite (Sat A or Sat B) extinguishes, while the indicator for the other satellite starts blinking.
3. Once the indicator for the other satellite turns solid green, the TracVision system is tracking the newly selected satellite. You can now use your IRD to choose a channel on the new satellite.



If you are a **DISH 500** customer, you can order the optional TV/SAT Switch – **free of charge**. Simply fill out the order form located at the back of this manual and fax it to KVH at +1 401 845-8190. Please take advantage of this free offer to make satellite switching a breeze!

3.2.3 Using a PC to Switch Between Satellites

If you're unable to switch between satellites using the IRD remote control, you can use a PC connected to the switchplate's maintenance port to select between Satellite A and Satellite B. The procedure requires terminal emulation software such as PROCOMM or Windows Terminal or Hyperterminal. Use the settings appropriate to your application.

To switch satellites using a PC, perform the following steps:

1. Connect one end of the PC data cable to the maintenance port on the switchplate (see Figure 3-5). Connect the other end to the serial port on your PC (a 9-pin/25-pin connector adapter may be needed for some PCs).

Figure 3-5
Switchplate Maintenance Port

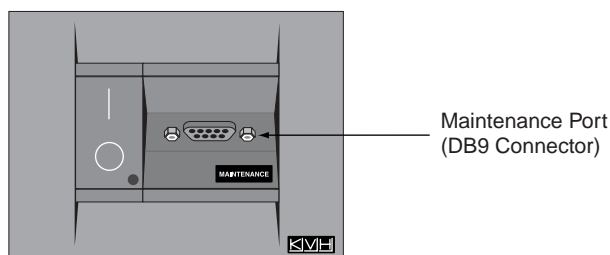

2. Open the terminal emulation software and establish the following settings:

- 9600 baud
- no parity
- 8 data bits
- 1 start bit
- 1 stop bit
- no flow control

3. Once the data connection is made, enter the Satellite Selection command as follows:

Command: **@L,x<cr>**
 (*<cr> indicates a carriage return/ENTER key*)

| | |
|--------|--|
| Where: | x = A or B (whichever satellite you want to track) |
|--------|--|

To select Satellite A, you would enter **@L,A<cr>**.

To select Satellite B, you would enter **@L,B<cr>**.

4. The antenna unit shifts to track the second satellite.

3.3 Watching Television

Turn on the TracVision S3 after your vehicle is parked. Once the startup procedure is complete and the antenna is locked onto your selected satellite, it is not necessary for the TracVision S3 to be turned on. You may turn off the TracVision S3 unit to avoid unnecessary use of power. Because the LNB receives its power from the IRD, the antenna will continue to receive the satellite TV signals and relay them to the IRD.

However, if you plan to change to a channel that is broadcast by another satellite, TracVision S3 must be turned on so the antenna can search for, identify, and lock onto the different satellite.

3.4 Internet Access

Your TracVision S3 can receive high-speed Internet data when used in conjunction with KVH's TracNet 2.0 Mobile High-speed Internet System. With TracNet 2.0, you get broadband Internet access on the road via satellite downloads and a wireless return path. For more information about TracNet 2.0 in North America and Europe, please visit our web site at www.kvh.com.



It is highly recommended that you turn off the TracVision S3 prior to moving the vehicle. TracVision S3 will not track a satellite while the vehicle is in motion.

4 Troubleshooting

The troubleshooting matrix shown in Table 4-1 identifies some trouble symptoms, their possible causes, and references to troubleshooting solutions.

Table 4-1
Troubleshooting Matrix

| SYMPTOM | POSSIBLE CAUSE (AND SOLUTION) | | | | | | | | | | |
|---|---|---|--|---|--|--|--|-------------------------------------|----------------------------|----------------------------|-----------------------------------|
| | Blown fuse or improper wiring (Section 4.1.1) | Incorrect satellite configuration (Section 4.1.2) | Satellite signal blocked (Section 4.1.2) | Dew or rain pooling on dome (Section 4.1.3) | Satellite coverage issue (Section 4.1.4) | Incorrect or loose RF connectors (Section 4.1.5) | Type of multiswitch used (Section 4.1.6) | Stationary use only (Section 4.1.7) | IRD wiring (Section 4.1.8) | IRD faulty (Section 4.2.1) | LNB assembly faulty (Section 4.3) |
| Antenna non-functional | X | | | | | | | | | | |
| Antenna not switching channels/satellites | | X | | | | X | | | | | |
| No picture on TV set | | | | X | X | X | | | X | X | |
| Intermittent picture for short intervals | | X | X | X | X | | X | X | X | | |
| System works at rest but not on the move | | | | | | | X | | | | |
| System will not find satellite | | X | X | X | X | | | X | X | | |
| Snowy television picture | | | | | | | | X | | | |
| Picture jumbled, parts missing, freezing | | | X | X | | | | | | | |
| TV/SAT Switch Error LED blinking | | | | | X | | | X | X | | |

4.1 Causes and Remedies for Common Operational Issues

There are a number of common issues that can affect the signal reception quality or the operation of the TracVision S3. The following sections address these issues and potential solutions.

4.1.1 Blown Fuse or Improper Wiring

If the antenna unit is installed but entirely non-responsive, there are three key factors to check as part of the troubleshooting process:

1. Blown Fuse – The antenna unit is equipped with two fuses mounted on its CPU Board. If either of these fuses has blown or been broken, the antenna unit will not operate. Refer to [Section 5.4.1, “PCB Removal and Replacement,”](#) for details on the fuse locations and how to access the CPU Board.
2. Wiring – If the system has been improperly wired, the antenna unit will not operate correctly. Refer to [Section 2.3, “Connecting System Components,”](#) for complete system wiring information.

4.1.2 Incorrect Satellite Configuration

The satellite configuration on your IRD must match the satellite setting on the TracVision S3 system.

- Satellite A on the TracVision S3 must be the same satellite as IRD Alternative 1 (or A, based on your IRD) and must be assigned the IRD DiSEqC 1 setting.*
- Satellite B on the TracVision S3 must be the same satellite as IRD Alternative 2 (or B, based on your IRD) and must be assigned the IRD DiSEqC 2 setting.*

* *The DiSEqC settings only apply to European systems.*

Refer to your IRD user manual for complete instructions on configuring your IRD.

4.1.3 Satellite Signal Blocked

Satellite signals can be blocked or degraded by trees and branches, buildings, mountains, or equipment on the vehicle itself. Refer to [Section 2.1, “Choosing the Best Location,”](#) to make certain that the TracVision S3 unit is in the optimal location. Simply moving the vehicle to clear an external obstruction will also restore signal quality.

4.1.4 Dew or Rain Pooling on Dome

Dew or rain can occasionally pool on the top of the radome. While this moisture will usually be dispersed when the vehicle is in motion, it can disrupt the signal while the vehicle is at rest. This issue can be minimized with two approaches:

1. Spray the dome with hosed water to remove the dew from the dome surface.
2. Periodically apply liquid dish detergent to the dome surface. Wipe the full-strength detergent on the dome and allow it to dry. This treatment will provide a film that will help moisture roll off the dome.

4.1.5 Satellite Coverage Issue

TracVision S3 will provide outstanding reception throughout the entire coverage area for your satellite television service of choice. However, signal quality can be degraded as you approach the fringe coverage areas. Refer to your satellite television service manual to check the viable coverage area.



For your convenience, KVH provides links to several web sites that offer satellite coverage information. Simply go to our web site at www.kvh.com/footprint/index.html.

4.1.6 Incorrect or Loose RF Connectors

As part of preventive maintenance (described in [Section 5, "Maintenance,"](#)) KVH recommends checking the antenna unit cable connections. A loose RF connector can reduce the signal quality. In addition, if you are unable to switch to the other programmed satellite, make sure that you have connected your RF signal cable to the antenna baseplate connector labeled "RF1". Refer to [Section 2.3.5, "Connecting the Antenna RF Signal Cable to the IRD"](#) for directions on proper antenna unit to RF cabling.



Baseline RF levels are included as part of the startup sequence provided in [Appendix D](#).

4.1.7 Type of Multiswitch Used (North American Systems Only)

An active (not passive) multiswitch must always be used to connect the TracVision S3 system to multiple IRDs. Refer to [Section 2.3.5, "Connecting the Antenna RF Signal Cable to the IRD"](#) for directions on proper multiswitch/multiple IRD cabling.



KVH offers an upgrade kit (KVH Part #02-1026) that adds in-motion tracking capability to the TracVision S3, allowing you to receive satellite signals while on the move.

4.1.8 Stationary Use Only

Your TracVision S3 antenna was designed for stationary use only. As such, the antenna will track the desired satellite while your vehicle is parked, but not while the vehicle is in motion.

4.2 IRD Troubleshooting

The IRD that was provided with your satellite television service may also be the cause of less-than-ideal operation.

4.2.1 IRD Wiring

Refer to [Section 2.3.5, “Connecting the Antenna RF Signal Cable to the IRD”](#) and your IRD user manual to confirm that the IRD is properly connected to the antenna unit and the television.

4.2.2 IRD Faulty

In the case of a faulty IRD, refer to your IRD user manual for service, replacement, and warranty information.

4.3 Antenna LNB Faults

[Section 5, “Maintenance,”](#) provides detailed instructions for authorized service personnel who may be required to replace the TracVision S3 antenna LNB.

4.4 Computer Diagnostics

TracVision S3 has been designed to provide diagnostic readouts on a personal computer having an RS-232 serial communication port. If you are unable to isolate a system problem with the foregoing troubleshooting tools, set up a laptop to carry out computer diagnostics as described below. System problems will most likely be found somewhere through the diagnostic readouts.

The diagnostics procedure requires terminal emulation software such as PROCOMM or Windows Terminal or Hyperterminal. Use the settings appropriate to your application.

1. Connect one end of the PC data cable to the DB9 connector on the switchplate. Connect the other end to the serial port on the PC (a 9-pin/25-pin connector adapter may be needed for some PCs).
2. Open the terminal emulation software and establish the following settings:
 - 9600 baud
 - no parity
 - 8 data bits
 - 1 start bit
 - 1 stop bit
 - no flow control
3. Apply power to the TracVision S3 system and allow the system to complete full initialization. Data should be scrolling on the PC display to identify any system problems detected. If no data is seen, recheck your connections and the terminal software setup.

4.5 Maintenance Port Parser Commands

TracVision S3 system parser commands are detailed in [Appendix E](#).

5 Maintenance

5.1 Warranty/Service Information

For information on KVH warranty, repair, and liability policies, please refer to the [complete warranty statement](#) provided at the conclusion of this manual. If you have any questions, please call your local authorized dealer/installer or distributor, or contact KVH or KVH Europe directly.

5.2 Preventive Maintenance

TracVision S3 requires minimal preventive maintenance. The following tasks are sufficient to maintain peak performance.

Monthly

- Wash the exterior of the radome and baseplate assembly with fresh water; a mild detergent may be added to remove grime. Do not spray the radome directly with high-pressure water.
- Do not apply abrasive cleaners or volatile solvents such as acetone to the ABS radome.



When cleaning the radome, avoid any compounds that react with plastic.

Annually

- Remove the radome and examine the interior of the antenna unit for signs of corrosion, loose connections, or frayed or broken wires.
- Visually inspect the elevation drive shaft to be certain that it moves easily and is clear of grit and debris.



The serial number of your TracVision S3 will be required during any troubleshooting or service calls. You will find the [serial number](#) at the front of this manual.

5.3 Replaceable Parts

TracVision S3 has been designed with durability and low maintenance in mind. If you experience an operating problem or otherwise require technical assistance, contact your local authorized TracVision S3 dealer/distributor first. Have the antenna unit serial number ready with a list of the trouble symptoms. If an authorized dealer/distributor is not located nearby, contact the factory directly at the telephone, facsimile, or e-mail listings inside the front cover.

Replacement part numbers for units that can be serviced in the field are listed in Table 5-1. These parts may be obtained from any KVH authorized dealer/distributor.

Table 5-1
Field Replaceable Units



Should a fuse ever need to be replaced, TracVision S3 uses two 5x20 mm, 3.15-amp, 250-volt fast-blow fuses.



To help us continually improve the quality and reliability of our systems, please return any failed component to KVH or KVH Europe (care of the [mailing address](#) listed at the front of this manual) after you receive your replacement part.

| Part Name | Part Number |
|--------------------------|-----------------------------|
| Baseplate Assembly | 02-1245-02* 02-1245-04** |
| Radome Assembly | 02-0953-05† |
| Data/Power Cable | 32-0730-28 |
| RF Cable | 32-0417-28 |
| PC Cable | 32-0628-06 |
| CPU PCB | 02-1043-02 |
| RF PCB | 02-1233 |
| System Fuses | 16-0017-3150 |
| LNB (European System) | 19-0196 |
| LNB (N. American System) | 19-0056 |
| Switchplate | 02-1023-01 |
| TV/SAT Switch (optional) | 01-0245 |

* Baseplate assembly with single-output LNB

** Baseplate assembly with dual-output LNB

† Specify color when ordering

It is recommended that all other technical difficulties be resolved by returning the TracVision S3 unit to an authorized service provider.

5.4 Field Replaceable Unit Procedures

The following subsections provide detailed procedures for repairing or swapping out field replaceable units. The procedures refer to labeled items presented on the following diagrams.



Always lift the antenna unit by the gray baseplate, never by the radome or any portion of the antenna assembly!

Figure 5-1
Antenna, PCB, and Rotating Plate

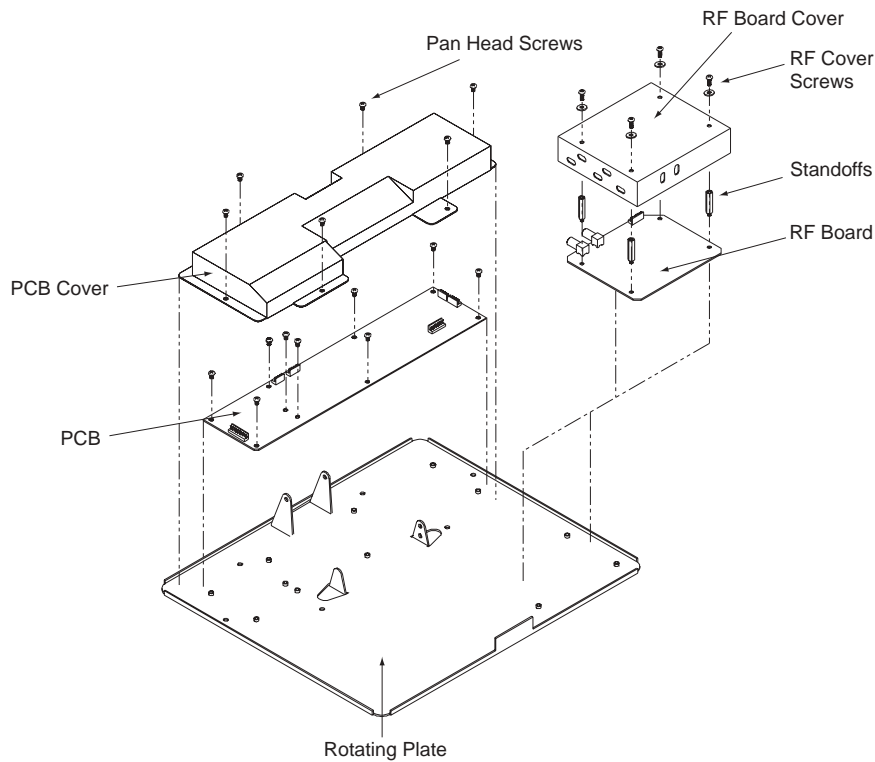

Before servicing the antenna unit, be sure to remove the appropriate vehicle fuse to disconnect power. Replace the fuse after completing the service.

Figure 5-2
Close-up of Connecting Rod and E-ring

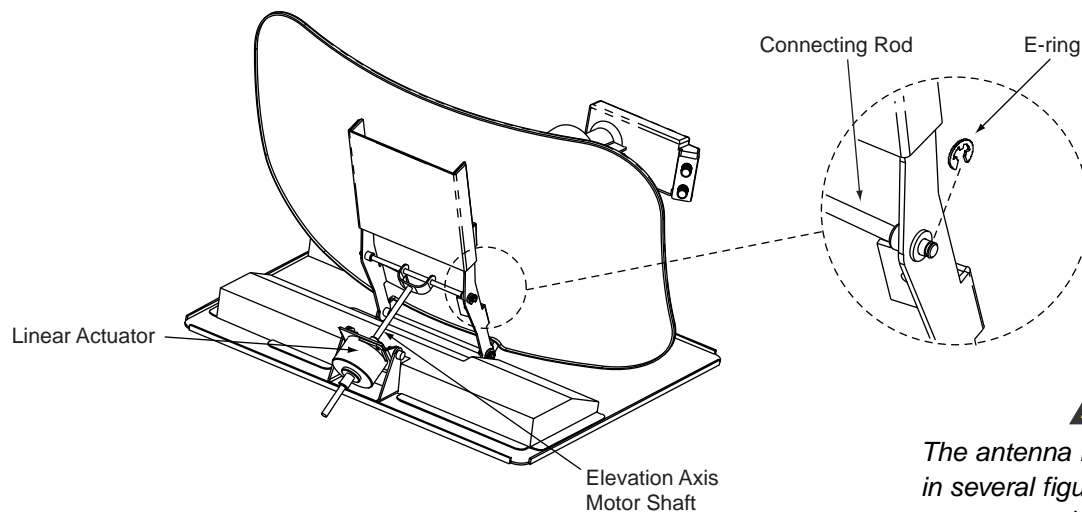

The antenna reflector is not shown in several figures for clarity purposes only. Do not remove the antenna reflector!

Figure 5-3
Antenna Assembly

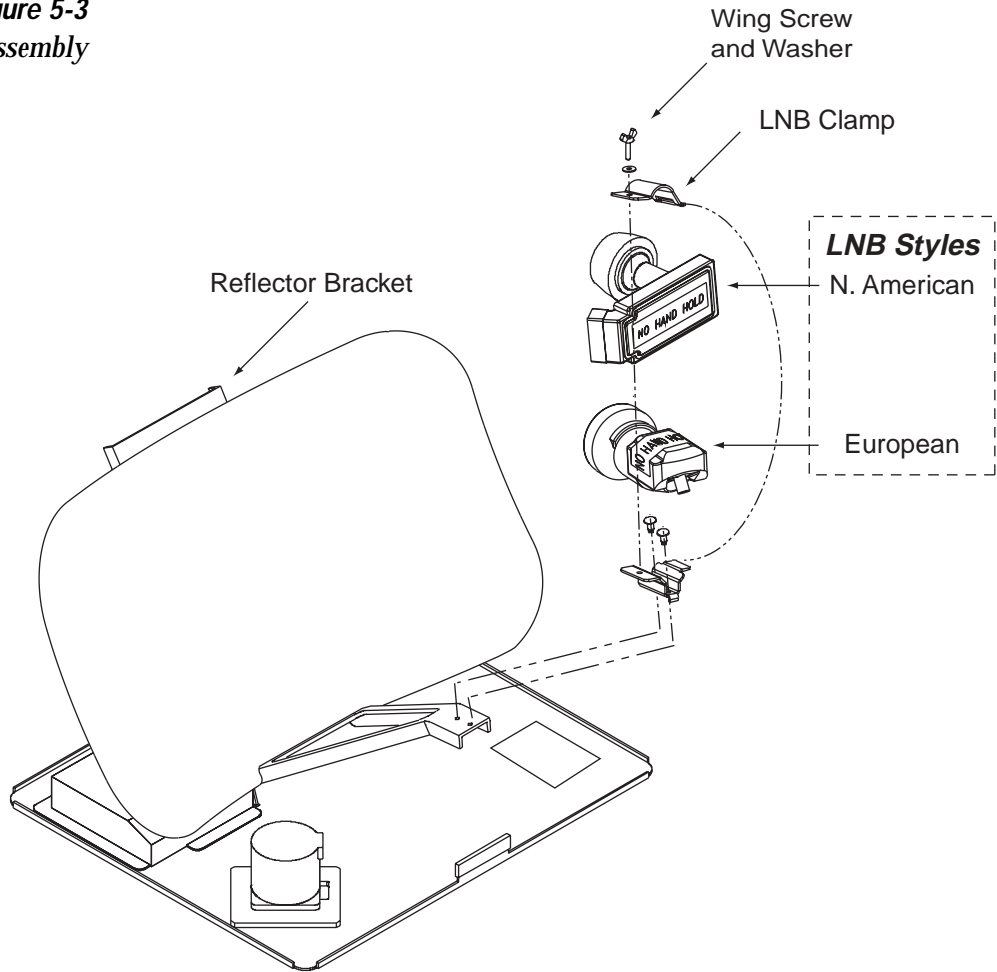
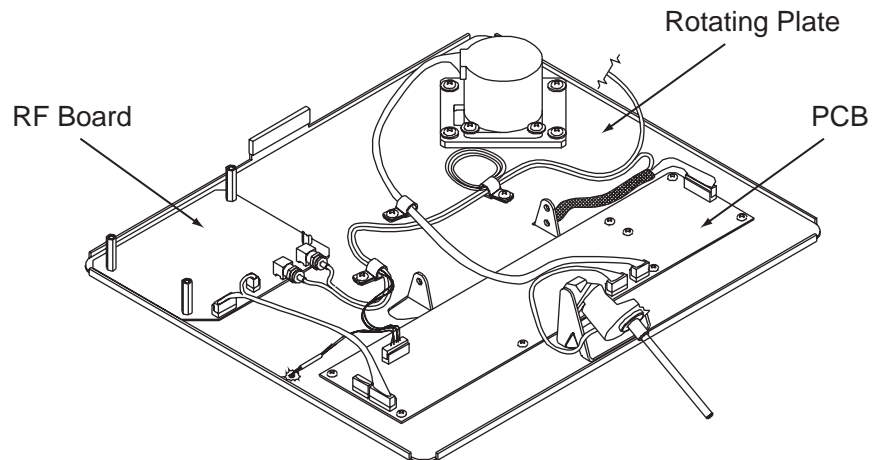

Figure 5-4
Close-up of RF Detector and PCB



5.4.1 PCB Removal and Replacement

Estimated Time to Repair: ½ hour

The microprocessor PCB assembly is protected by a cover fastened to the rotating plate – [Fig. 5-1](#). The cover must be removed to gain access to the main power fuses and the PCB assembly.

1. Using needle-nose pliers, remove the E-ring from one end of the connecting rod – [Fig. 5-2](#).
2. Remove the connecting rod by sliding it off the bracket.
3. Fully retract the elevation axis motor shaft – [Fig. 5-5](#).

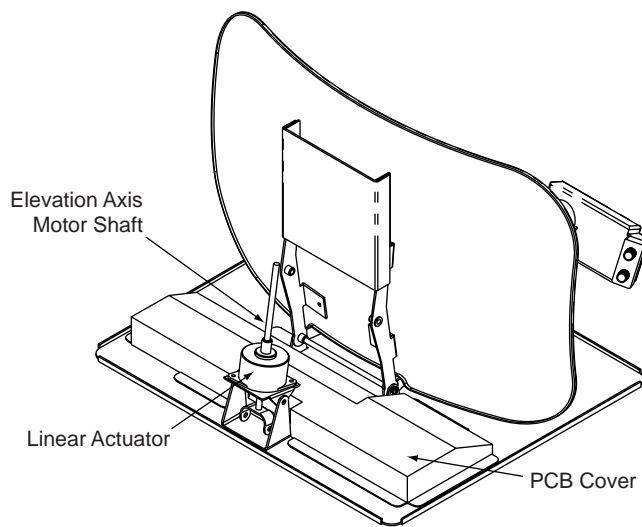

4. Remove 6 pan head screws from the PCB cover flanges.
5. Remove the PCB cover. To get the necessary clearance, rotate the linear actuator up 90° while lifting the PCB cover – [Fig. 5-5](#).
6. Remove all cable connectors from the PCB. [Figure 5-6](#) on the following page illustrates the PCB arrangement and connector locations.



*When carrying out maintenance on the PCB, be sure to not drop any of the small screws inside the mechanism. If a screw is lost within the baseplate, it **must** be retrieved to avoid causing any damage when the unit rotates.*

Figure 5-5
Removing the PCB Cover



TracVision S3 is equipped with two 5x20 mm, 3.15-amp, 250-volt fast-blow fuses, which are mounted on the PCB. To access and replace one of the fuses, remove the PCB cover.

Figure 5-6
PCB and RF Detector Board
Connector Locations

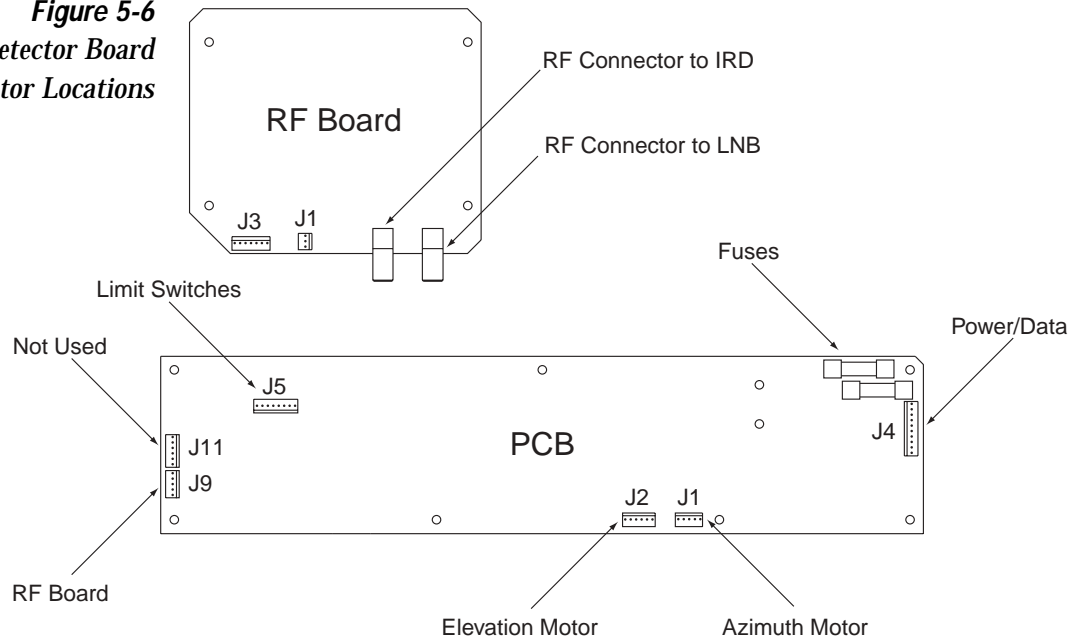

When replacing the PCB cover, be careful not to pinch any cables.

7. The PCB is mounted to the rotating plate with 9 pan head screws. Remove the screws and PCB.
8. Reverse this process to install the replacement PCB. Reinstall all cable connectors removed in [Step 6](#).
9. Reinstall your preferred satellites as detailed in [Section 2.5.1, "Installing Your Selected Satellites."](#)

5.4.2 RF Detector/DVB Decoder

Estimated Time to Repair: ½ hour

The RF Detector PCB receives operating voltages from both the CPU board and the IRD (via the RF cable). Ensure that all power is turned off before proceeding.

1. Remove the 4 RF board cover screws and washers from the RF board cover.
2. Remove the RF board cover.
3. Remove the 2 RF connectors from the coaxial fittings on the PCB. Tag the cables to ensure that they are returned to the same connectors.
4. Remove the 2 Molex connectors from the RF board (J3 and J1) – [Fig. 5-6](#).
5. Remove the 4 standoffs – [Fig. 5-1](#). Remove the RF Detector PCB from the rotating plate.

6. Installation of the replacement RF Detector PCB is the reverse of this procedure. Be sure that the RF cables are restored to their original positions. Also be sure that the center conductor pin is centered in the connector before tightening the collar.

5.4.3 Antenna LNB Replacement

Estimated Time to Repair: ½ hour

In the event that the LNB experiences problems, it may be necessary to replace it. To do so, use the following procedure:

1. *(European systems only)* Make a note of the current LNB skew angle, pictured in Figure 5-7.
2. Disconnect the RF cable connector(s) at the LNB.
3. Remove the wing nut and washer from the LNB clamp – *Fig. 5-3*.
4. Remove the top of the LNB clamp and remove the LNB.
5. Place the new LNB in the clamp and reattach the RF connector(s).
6. Replace the LNB clamp:
 - A. For North American LNBs, tighten the clamp fully. The replacement process is complete.
 - B. For European LNBs, do not fully tighten the clamp and proceed to Step 7.
7. *(European systems only)* Carefully turn the LNB so that the scribe mark is aligned with the skew angle noted in Step 1. Fully tighten the clamp to complete the replacement process.



The LNB receives power from the IRD via the RF Detector PCB. Be certain that the IRD is disconnected from its power source before removing or reconnecting the LNB.

Figure 5-7
LNB Skew Angle Setting
(European Systems Only)

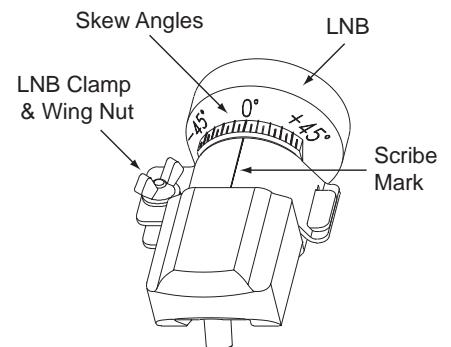

5.5 Preparation for Shipment



When rotating the azimuth mechanism by hand, go slowly! Hitting the mechanical stops with excessive force will damage the azimuth limit switch.

If it is necessary to repack the antenna unit for shipment, the shipping restraints removed or stowed during installation must be replaced. Follow these steps to reinstall the restraints.

1. Rotate the antenna unit so that the LNB is facing away from the baseplate connectors.
2. Attach the three restraints to the baseplate using the $\frac{1}{4}$ "-20 x $\frac{5}{8}$ " hex screws and washers (provided as part of the kitpack) and nuts (removed from the shipping restraints during installation) as pictured in Figure 5-8.

Figure 5-8
Attaching the Shipping Restraints to the Antenna Baseplate

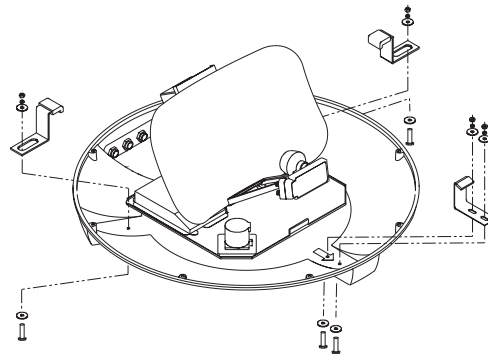

3. Place the antenna bracket on the forward shipping restraint.
4. Secure the forward restraint and bracket by wrapping two tie-wraps around the bend in the forward restraint and the antenna bracket (at the end of the LNB bracket).

Figure 5-9
Securing the Forward Shipping Restraint

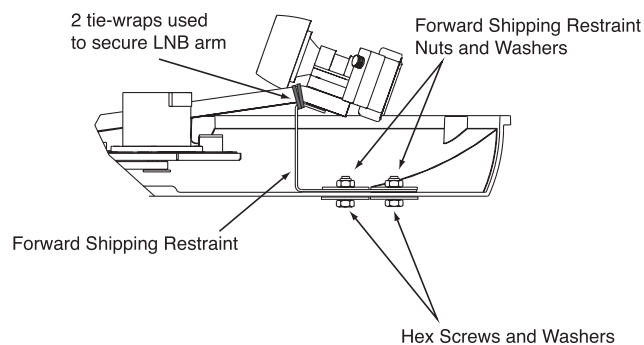

KVH is not liable for damage caused by improper shipping.

5. Place the entire antenna unit into its shipping box using the original packaging material.

Appendix A

System Specifications

Physical Characteristics

| | |
|-------------------|---|
| Power | 11-16 volts DC @ 2.5 amps nominal, 3.5 amps peak |
| Dimensions/Weight | 32" (81 cm) wide x 14.8" (38 cm) high, 33 lbs (15 kg) |
| LNB | European System: Single Output N. American System: Dual Output |
| Maintenance Port | 9600 bps, 8,N,1,EIA, RS232 |

Table A-1

*TracVision S3 System
Specifications*

Pointing System

| | |
|------------------------|------------|
| Elevation Range | 15° to 75° |
| Azimuth Range | 720° |
| Position Repeatability | 0.1° |

Environmental

| | |
|-----------------------|----------------------------------|
| Operating Temperature | -25°C to +55°C (-13°F to +131°F) |
| Storage Temperature | -40°C to +85°C (-40°F to +185°F) |
| Humidity | to 100 percent |

Appendix B

Comprehensive TracVision S3 System Wiring Diagram

The wiring diagram is presented on the following page.

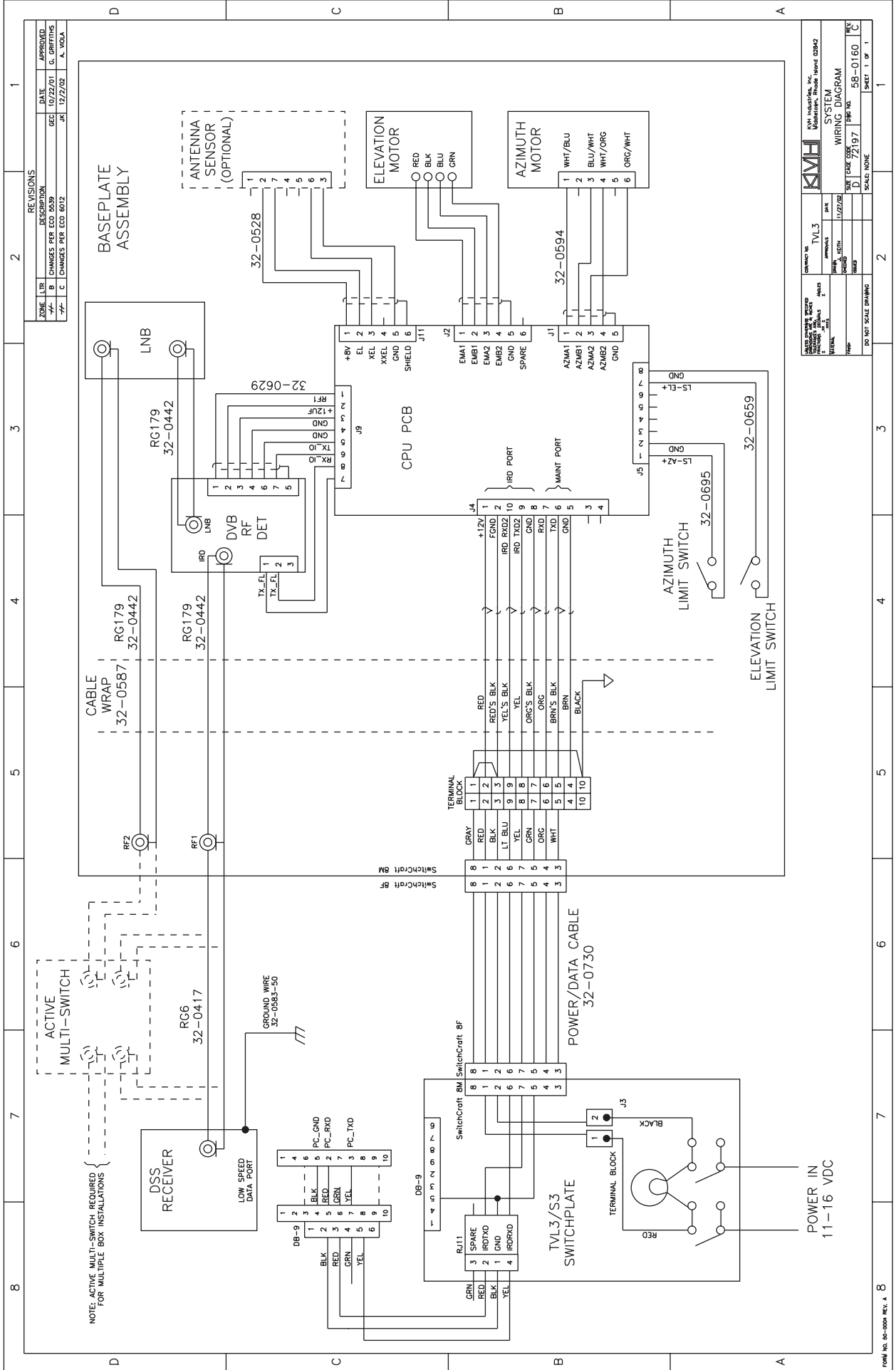

REVISIONS

| ZONE | TR | DESCRIPTION | DATE | APPROVED |
|------|----|------------------------|----------|------------|
| 1 | 1 | ISSUE FOR CONSTRUCTION | 10/22/01 | G. GRIFTHS |
| 2 | B | CHANGES PER ECO 5539 | | |
| 3 | C | CHANGES PER ECO 6012 | 12/2/02 | A. WOLA |

NOTE: ACTIVE MULTI-SWITCH REQUIRED FOR MULTIPLE BOX INSTALLATIONS

ACTIVE MULTI-SWITCH

WIRING DIAGRAM

| DATE | REVISED | BY | DATE | APPROVED |
|----------|---------|----|------|----------|
| 11/27/02 | | | | |

PROJECT NO. 55-0160

SHEET 1 OF 1

POWER IN 11-16 VDC

TVL3/S3 SWITCHPLATE

POWER/DATA CABLE 32-0730

GROUND WIRE 32-0583-50

RG6 32-0417

RG179 32-0442

RG179 32-0442

RG179 32-0442

32-0587

32-0528

32-0629

32-0659

32-0695

32-0594



Appendix C

Switchplate Template

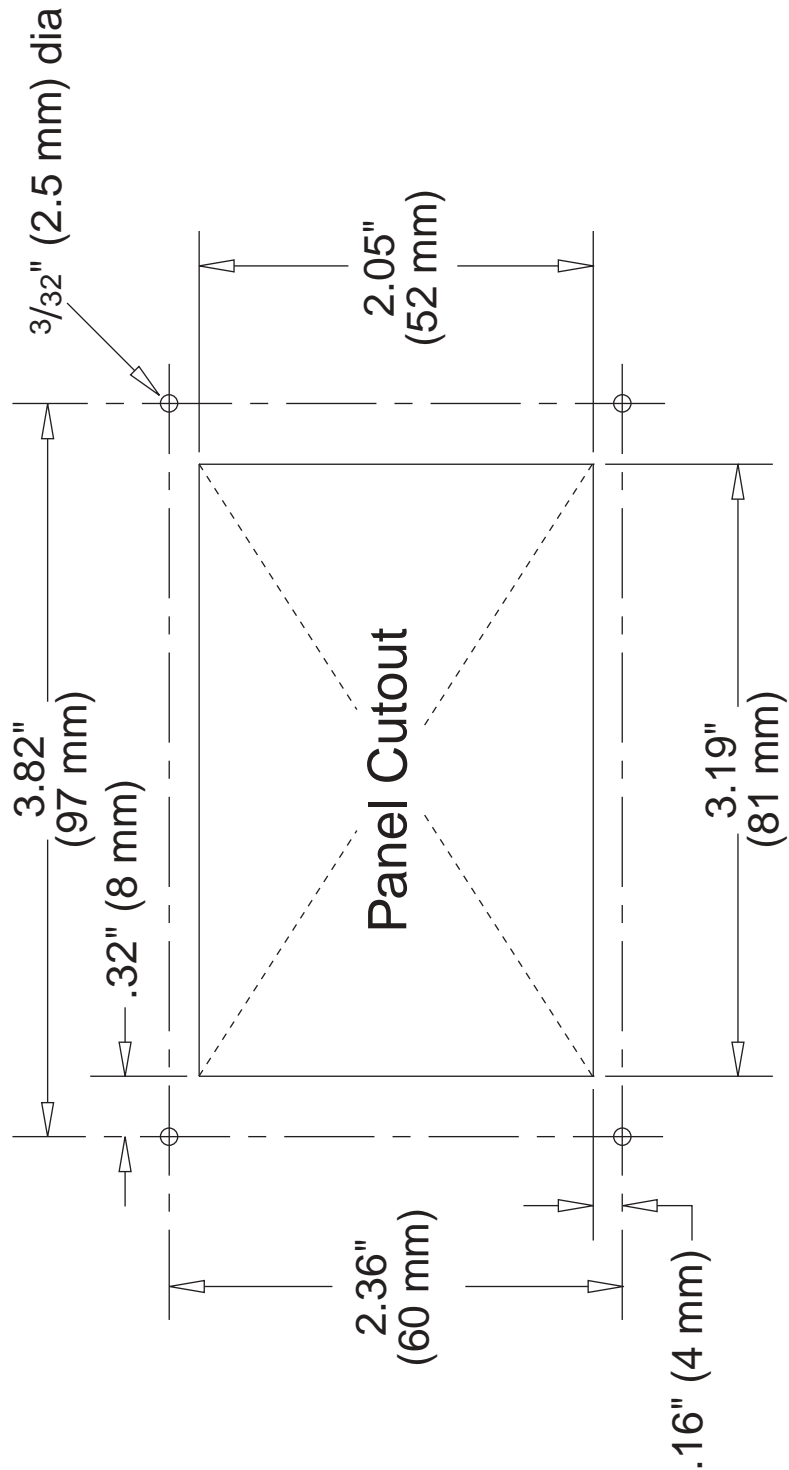

Appendix D

Startup Data Sequence

The data on the following pages presents a standard startup data sequence registered by the TracVision S3. This sequence can be recorded using the data port and a PC.

```
?PGM
KVH TracVision S3 Rev X - Version X.XX - Serial Number XXXXXXXX
RF: ZAP
*** Initializing RF Controller ***
RF: S,A,V,U,V
RF: SATINSTALL,55,C,57,C
RF: L,A-----Identifies Satellite A or B as currently
RF: SATCONFIG                               loaded for acquisition
RF: F,A,12368,20000,67,0X0000,V,U,2-----Satellite configuration data, Satellite A
RF: F,A,12368,20000,67,0X0000,V,U,2
RF: F,A,12238,20000,67,0X0000,H,U,2
RF: F,A,12238,20000,67,0X0000,H,U,2
RF: F,B,12374,20000,34,0X1004,V,U,3-----Satellite configuration data, Satellite B
RF: F,B,12374,20000,34,0X1004,V,U,3
RF: F,B,12381,20000,34,0X1004,H,U,3
RF: F,B,12381,20000,34,0X1004,H,U,3
RF: RF PCB Version X.X-----Current RF software revision
RF: I,0,48492,00000,00425,0
RF COMM: PASS-----PASS is expected
*** Initializing Antenna ***
GPS: UTC: 083000.00, Lat: 4131.00N, Long: 7115.00W
GPS: DSS_119 AZ = 238.9, EL = 22.1
GPS: DSS_101 AZ = 220.9, EL = 33.4
Limit Switch Test
Limit Switch Status: PASS-----PASS is expected
*** Limit Switch Search ***
Searching for DSS_101, Threshold = 1000
Satellite Found: AZ = 177.1, EL = 34.0, RF = 1968
RF: Freeze DAC = +01256
+POS: 170.6 34.0 1971
RF: S,A,V,U,V
RF: AGAIN #1
*** Initializing Finetune ***
+POS: 177.7 34.0 2057
+POS: 175.4 34.0 2684
+POS: 175.4 34.0 2659
Signal Peaked: AZ = 175.33, EL = 33.98, RF = 2674
*** Network ID Check ***-----Comparing the tracked satellite's network ID
+POS: 175.3 33.9 2615                               to the selected satellite's network ID
+POS: 175.3 33.9 2580
```

RF: Y,0X0000-----Indicates positive satellite identification
*** Tracking DSS_101 ***-----Identifies satellite currently tracked
+POS: 175.3 33.9 2564 (TV broadcast image should be available)
+POS: 175.3 33.9 2502
+POS: 175.3 33.9 2497
+POS: 175.3 33.9 2488
+POS: 175.3 33.9 2496
Saved Sat Pos: AZ = 175.27, EL = 33.91

Appendix E

Maintenance Port Parser Commands

TracVision S3 system parser commands are parsed when the system receives an ASCII carriage return (Hex 0D). An ASCII line feed (Hex 0A) is permitted but is ignored in any transmitted command. All system responses are terminated with an ASCII carriage return followed by a line feed and ending with either an acknowledge character (ASCII > (Hex 3E)) or a not-acknowledge character (ASCII ? (Hex 3F)). The parser commands are shown below in boldface capital letters but they are not case-sensitive. In most cases the command is responded to with an echo; that is, if you type **ZAP**, for example, and press “ENTER” the response will be the command you have entered. For other commands the response is specific for each command, such as **VERSION**, **STATUS** or **HELP**.

E.1 System Commands

Software Version

| | |
|-----------|--|
| Function: | reports software version and system type |
| Command: | VERSION |
| Argument: | none |
| Response: | KVH TracVision S3 Version XX.XX |

*Table E-1
System Commands*

System Status Report

| | |
|-----------|-------------------------------|
| Function: | reports general system status |
| Command: | STATUS |
| Argument: | none |
| Response: | system status string |

Initialize the System

| | |
|-----------|---|
| Function: | initializes the system (perform a soft reset) |
| Command: | ZAP |
| Argument: | none |
| Response: | echoes the command, then reinitializes the system |

Find Skew Angle for Currently Selected Satellite

| | |
|-----------|--|
| Function: | calculates necessary LNB skew based on latitude, longitude, and selected satellite |
| Command: | SKEWANGLE* |
| Argument: | none |
| Response: | displays skew angle |

* Before this command can function properly, you must perform the GPS Position command detailed in [Section E.6](#) to provide the system with the proper latitude and longitude.

Help on Parser Commands

| | |
|-----------|--------------------------------------|
| Function: | lists parser commands |
| Command: | HELP |
| Argument: | none |
| Response: | prints a list of all parser commands |

E.2 Manual Positioning Commands

To execute the following commands, first put the antenna unit in idle mode by typing **HALT** and pressing “ENTER.” Positioning commands may be entered after the antenna comes to rest.

*Table E-2
Manual Positioning Commands*

Azimuth Angle

| | |
|-----------|---|
| Function: | commands a manual azimuth angle that the mechanism moves to |
| Command: | AZ,xxxx (range is 0000-3599) |
| Argument: | desired azimuth angle of the mechanism relative to external magnetic reference, or baseplate fwd, 000°-359.9° |
| Response: | echoes the command; mechanism moves at a fixed velocity |

Elevation Angle

| | |
|-----------|--|
| Function: | commands a manual elevation angle that the mechanism moves to |
| Command: | EL,xxx (range is 100-850) |
| Argument: | desired elevation angle of the mechanism relative to up, 10.0°-85.0° |
| Response: | echoes the command; mechanism moves at a fixed velocity |

Azimuth CW Step

| | |
|-----------|--|
| Function: | commands a 0.1 deg CW manual step in azimuth angle |
| Command: | 6 |
| Argument: | none |
| Response: | echoes the command |

Azimuth CCW Step

| | |
|-----------|---|
| Function: | commands a 0.1 deg CCW manual step in azimuth angle |
| Command: | 4 |
| Argument: | none |
| Response: | echoes the command |

Elevation UP Step

| | |
|-----------|--|
| Function: | commands a 0.1 deg UP manual step in elevation angle |
| Command: | 8 |
| Argument: | none |
| Response: | echoes the command |

Elevation DOWN Step

| | |
|-----------|--|
| Function: | commands a 0.1 deg DOWN manual step in elevation angle |
| Command: | 2 |
| Argument: | none |
| Response: | echoes the command |

E.3 Operational Commands

To execute the following commands, first put the antenna unit in idle mode by typing **HALT** and pressing “ENTER.” After the system comes to a halt, type **DEBUGON** and press “ENTER” to enter programming mode.

Table E-3
Operational Commands

| Tracking Mode | |
|---------------------------------|---|
| Function: | starts active tracking of the satellite |
| Command: | TRACK |
| Argument: | none |
| Response: | echoes the command |
| Idle Mode | |
| Function: | halts active tracking and conical scan, then enters idle mode |
| Command: | HALT |
| Argument: | none |
| Response: | echoes the command |
| Current Cable Wrap Angle | |
| Function: | sets or reports current cable wrap angle, defined as 0° (CCW limit) to 700° (CW limit); the value is expressed as 0000-7000 with an implied decimal |
| Command: | WRAPANGLE,xxxx |
| Argument: | the desired cable wrap angle setting |
| Response: | Wrap Angle = xxxx |

E.4 Tracking and Conical Scan Commands

Table E-4
Tracking and Conical Scan Commands

| Target Location | |
|------------------------|--|
| Function: | reports the target location in antenna frame. Data format is E### for elevation in degrees 000-900 and A##### for azimuth in degrees 0000-3599 with implied decimals |
| Command: | TGTLOCATION |
| Argument: | none |
| Response: | Target Location = A = E###, A##### B = E###, A##### |

Analog Signal Strength Report

| | |
|-----------|--|
| Function: | reports signal strength from RF detector circuit in A/D counts (000-FFF Hex) |
| Command: | SIGLEVEL |
| Argument: | none |
| Response: | Signal Strength = xxxx |

E.5 RF Board Commands**Serial Communications, Status/Polarization Report, Tone Changes**

| | |
|-----------|--|
| Function: | start serial communications, reports status & polarization/tone changes |
| Command: | @S |
| Response: | S,s,p,b,m <cr> every 5 seconds until ><cr>is returned from system software |
| Where: | s = Satellite (a = Primary, b = Secondary) p = Polarization (v = Vertical, h = Horizontal, r = Right, l = Left, x = No LNB Power) b = Band (h = High Band, l = Low Band, u = USA) m = Mode (v = Valid, i = Invalid)* |

* The Mode bit is used to evaluate the Satellite, Polarization, & Band combination vs. the Frequency/Symbol Rate/FEC currently in RAM. This bit will be set to invalid if the Frequency for the selected combination is set to 0x0000; otherwise it will be set to valid.

Table E-5*RF Board Commands*

Report RF Tracking Parameters

| | |
|-----------|---|
| Function: | reports all RF tracking parameters for primary & secondary satellites* |
| Command: | @SATCONFIG |
| Response: | F,x,ffff,S,C,ID,P,B,D <cr> |
| Where: | <p>x = Satellite (a = Primary, b = Secondary)</p> <p>ffff = Frequency in MHz (00000 and 10700 to 12700)</p> <p>S = Symbol rate in Mbit/Sec (1000 to 29999)</p> <p>C = FEC code rate (valid rates = 12, 23, 34, 56, 67, 78)</p> <p>ID = Satellite Network ID in hexadecimal format (valid range = 0x0000 to 0xffff hex)</p> <p>P = LNB Polarization (v = vertical, h = horizontal, r = right, l = left)</p> <p>B = the LNB down conversion frequency (l = low, h = high, u = USA)</p> <p>D = decoding type (0 = test, 1 = DSS-A, 2 = DSS-B, 3 = DVB)</p> |

* This command dumps all eight combinations of the Satellite/Freq/Sym/FEC/ID/POL/Band/Decode currently stored in RAM.

Set RF Tracking Parameters

| | |
|-----------|--|
| Function: | sets RF tracking parameter |
| Command: | @SATCONFIG,X,N,F,S,C,ID,P,B,D<cr> |
| Response: | Echoes the input data |
| Where: | <p>@SATCONFIG = directs data to the RF Board</p> <p>X = satellite location A or B</p> <p>N = satellite table # (98 & 99 are slots for user-configured satellites)</p> <p>F = frequency in MHz (either 00000 or a range from 10700 - 12700)</p> <p>S = the satellite transponder symbol rate in Mbit/second (01000 - 29999)</p> <p>C = the FEC code (e.g., 12, 23, 34, 56, 67, 78)</p> <p>ID = the satellite network ID in hexadecimal format (0x####)</p> <p>P = the LNB polarization (v = vertical, h = horizontal, r = right, l = left)</p> <p>B = the LNB down conversion frequency (l = low, h = high, u = USA)</p> <p>D = decoding type (0 = test, 1 = DSS-A, 2 = DSS-B, 3 = DVB)</p> |

ID Match/Decoded Network ID

| | |
|-----------|---|
| Function: | report ID match and decoded network ID |
| Command: | @CHECKID |
| Response: | Y,0X#### N,0X#### Y,NoID N,NoID |
| Where: | Y = yes N = no 0X#### = network ID NoID = satellite unidentified |

E.6 Installation Commands

To execute the following commands, first put the antenna unit in idle mode by typing **HALT** and pressing “ENTER.” After the system comes to a halt, type **DEBUGON** and press “ENTER” to enter programming mode.

Select Active Satellite

| | |
|-----------|---|
| Function: | switch antenna tracking to/from satellite A and B |
| Command: | @L,x |
| Where: | x = A or B (as defined during the SATINSTALL process) |

*Table E-6
Installation Commands*

Set/Report GPS Position

| | |
|-----------|---|
| Function: | reports or sets default GPS position |
| Command: | GPS<cr> GPS,XX,D,YYY,E |
| Response: | GPS = XXD YYYY<cr> GPS: XXD YYYY |
| Where: | XX = latitude (0-90) D = S (South) or N (North) YYY = longitude (0-180) E = E (East) or W (West) |

Report Satellite Names

| | |
|-----------|--------------------------------------|
| Function: | report names for satellites A and B |
| Command: | SATINSTALL |
| Response: | SATINSTALL,<sat_a_name>,<sat_b_name> |

Report Configured Satellite Names

| | |
|-----------|--|
| Function: | report names for all configured satellites |
| Command: | SATLISTA |
| Response: | SATLISTA,<sat_name1>,...,<sat_nameX> |

Report Valid Satellite B Selections

| | |
|-----------|---|
| Function: | report names for all valid satellite B selections for a given satellite A selection |
| Command: | SATLISTB,<sat_a_name> |
| Response: | SATLISTB,<sat_a_name>,<sat_b_name1>,...,<sat_b_nameX> |

Install Satellite Pair

| | |
|-----------|--|
| Function: | installs satellites A and B as the satellite pair |
| Command: | SATINSTALL,<sat_a_name>,<sat_b_name> |
| Response: | if valid pair, echoes the input data if invalid pair, returns error message |

Configure Longitude of a User-configurable Satellite

| | |
|-----------|---|
| Function: | configures one of the user-configurable satellites with the longitude provided |
| Command: | SATCONFIG,USERX,YYY,Z,D,L |
| Response: | if valid pair, echoes the input data if invalid pair, returns error message |
| Where: | X = 1 or 2 YYY = longitude (0-180) Z = E (East) or W (West) D = decoding type (0 = test, 1 = DSS-A, 2 = DSS-B, 3 = DVB) L = LNB polarization (c = circular, l = linear) |

E.7 Debug Commands

Report Offset Angles

| | |
|-----------|---|
| Function: | reports system offset angles |
| Command: | OFFSETS OFFSETS,XXXXX,YYYY |
| Response: | Offsets = XXXXX.X XXXXX.X |
| Where: | X = new azimuth offset (-1800 - 1800) Y = new elevation angle (-450 - 450) |

Table E-7
Debug Commands

Applies Default Values to Default Satellites

| | |
|-----------|---|
| Function: | updates the default satellites to the default values |
| Command: | SATPAIR,X |
| Response: | displays numerous frequency commands and reports "Satellite Installation Complete" |
| Where: | X = 0 (satellites default to Astra1 and Hotbird) or X = 1 (satellites default to EchoStar 119 and Expressvu) or X = 2 (satellites default to DSS 101 and DSS 119) |

Report Last Satellite Tracked/Update Value

| | |
|-----------|---|
| Function: | reports the last satellite tracked or updates the last tracked satellite to the value input if it is different from the current value |
| Command: | LASTSAT LASTSAT,X |
| Response: | Last = <sat_name> |
| Where: | X = A (updates to satellite A) or X = B (updates to satellite B) |

KVH Industries Limited Warranty

TracVision S3

Limited Warranty on Hardware

KVH Industries, Inc. warrants the KVH product purchased against defects in materials for a period of TWO (2) years and against factory labor costs for a period of ONE (1) year from the date of original retail purchase by the original purchaser. It is the customer's responsibility to verify the date of purchase by returning the warranty card included with the product to KVH within 30 days of purchase, or by providing a copy of a dated sales receipt for the KVH product under warranty with the warranty claim. If this date cannot be verified, the warranty period will begin 30 days after the date of manufacture of the original product purchased.

If you discover a defect, KVH will, at its option, repair, replace or refund the purchase price of the product at no charge to you, provided you return it during the warranty period, transportation charges prepaid, to the factory direct. Please attach your name, address, telephone number, a description of the problem and a copy of the bill of sale or sales receipt as proof of date of original retail purchase, to each product returned to warranty service. Alternatively, you may bring the product to an Authorized KVH dealer/distributor for repair. During the first year, and if the product was installed by an Authorized KVH dealer/distributor (identified with the KVH Authorized dealer/distributor list), KVH will cover the dealer's/distributor's labor charges for warranty repairs, provided the dealer/distributor contacts KVH for pre-approval of the charges. Approval of charges is at KVH's sole discretion.

This Limited Warranty does not apply if the product has been damaged by accident, abuse, misuse or misapplication or has been modified without the written permission of KVH; if any KVH serial number has been removed or defaced; or if any factory-sealed part of the system has been opened without authorization.

Return Authorization

A Return Material Authorization is required prior to returning the product to KVH Industries. Please call our Technical Support Department at +1 401 847-3327 or send an e-mail to techs@kvh.com to obtain the RMA number. Write the number in large, clear characters on the outside of the box. To avoid confusion and misunderstandings, shipments without an RMA number clearly visible on the outside box will be refused and returned to you at your expense. If possible, use the original box and packing material to protect the equipment from damage in shipment. KVH assumes no responsibility for warranty shipments from the customer to the factory if not shipped in the manner prescribed above.

THE EXPRESS WARRANTIES SET FORTH ABOVE ARE THE ONLY WARRANTIES GIVEN BY KVH WITH RESPECT TO ANY PRODUCT FURNISHED HEREUNDER; KVH MAKES NO OTHER WARRANTIES, EXPRESS, IMPLIED OR ARISING BY CUSTOM OR TRADE USAGE, AND SPECIFICALLY DISCLAIMS ANY WARRANTY OF MERCHANTABILITY OR OF FITNESS FOR A PARTICULAR PURPOSE. SAID EXPRESS WARRANTIES SHALL NOT BE ENLARGED OR OTHERWISE AFFECTED BY TECHNICAL OR OTHER ADVICE OR SERVICE PROVIDED BY KVH IN CONNECTION WITH ANY PRODUCT.

KVH's liability in contract, tort or otherwise arising out of or in connection with any product shall not exceed the price paid for the product. IN NO EVENT SHALL KVH BE LIABLE FOR SPECIAL, PUNITIVE, INCIDENTAL, TORT OR CONSEQUENTIAL DAMAGES OR LOST PROFITS OR GOODWILL (INCLUDING ANY DAMAGES RESULTING FROM LOSS OF USE, DELAY IN DELIVERY OR OTHERWISE) ARISING OUT OF OR IN CONNECTION WITH THE PERFORMANCE OR USE OR POSSESSION OF ANY PRODUCT, OR ANY OTHER OBLIGATIONS RELATING TO THE PRODUCT, EVEN IF KVH HAS BEEN ADVISED OF THE POSSIBILITY OF SUCH DAMAGES.

If any implied warranty, including implied warranties of merchantability and fitness for a particular purpose, cannot be excluded under applicable law, then such implied warranty shall be limited in duration to ONE (1) YEAR from the date of the original retail purchase of this product by the original purchaser.

Some states/countries do not allow the exclusion or limitation of implied warranties or liability for incidental or consequential damages, so the above limitations may not apply to you. This warranty gives you specific legal rights, and you may also have other rights which vary from state/country to state/country.



KVH Industries, Inc.

50 Enterprise Center Middletown, RI 02842 U.S.A.
Phone: (401) 847-3327 Fax: (401) 849-0045
E-Mail: info@kvh.com Internet: www.kvh.com

KVH Europe A/S

Ved Klaedebo 12 2970 Hoersholm Denmark
Phone: +45 45 160 180 Fax: +45 45 867 077
E-Mail: info@kvh.dk Internet: www.kvh.com